

SERVICE MANUAL

AA-2W CHASSIS

<u>MODEL</u>	<u>DEST.</u>	<u>COMMANDER</u>	<u>CHASSIS NO.</u>
KV-32FS10	U.S.	RM-Y168	SCC-S32B-A
KV-32FS10	CND	RM-Y168	SCC-S33B-A
KV-36FS10	U.S.	RM-Y168	SCC-S32C-A
KV-36FS10	CND	RM-Y168	SCC-S33C-A
KV-32FV15	U.S.	RM-Y171	SCC-S32D-A
KV-32FV15	CND	RM-Y171	SCC-S33D-A
KV-34FV10	E	RM-Y168	SCC-S34E-A
KV-34FV15	E	RM-Y171	SCC-S34F-A
KV-34FV15C	E	RM-Y171	SCC-S34G-A
KV-34FV15K	KOREA	RM-Y149A	SCC-S31B-A
KV-34FV15T	TAIWAN	RM-Y171	SCC-S36A-A
KV-36FV15	U.S.	RM-Y171	SCC-S32G-A
KV-36FV15	CND	RM-Y171	SCC-S33G-A
KV-38FV15K	KOREA	RM-Y149A	SCC-S31C-A
KV-34FX250C	E	RM-Y170	SCC-S34H-A
KV-38FX250	E	RM-Y170	SCC-S34M-A
KV-38FX250C	E	RM-Y170	SCC-S34J-A
KV-38FX250T	TAIWAN	RM-Y170	SCC-S36B-A
KV-32XBR250	U.S.	RM-Y170	SCC-S32E-A
KV-32XBR250	CND	RM-Y170	SCC-S33E-A
KV-36XBR250	U.S.	RM-Y170	SCC-S32F-A
KV-36XBR250	CND	RM-Y170	SCC-S33F-A



KV-36XBR250



RM-Y170



TRINITRON® COLOR TV
SONY®

SPECIFICATIONS

	KV-32FS10	**KV-32FV15 *KV-32XBR250	**KV-34FV10 **KV-34FV15 **KV-34FV15C **KV-34FV15K **KV-34FV15T *KV-34FX250C	KV-36FS10	**KV-36FV15 *KV-36XBR250	**KV-38FV15K *KV-38FX250 *KV-38FX250C *KV-38FX250T
Power Requirements	120V,60Hz	120V,60Hz	120-220V,50/60Hz	120V,60Hz	120V,60Hz	120-220V,50/60Hz
Number of inputs/outputs						
Video 1)	3	3	3	3	3	3
S Video 2)	2	2	2	2	2	2
Y, P _B , P _R 3)	1	1	1	1	1	1
Audio 4)	3	3	3	3	3	3
Audio Out 5)	1	1	1	1	1	1
Monitor Out	1	1	1	1	1	1
TV Out 1) 4)	1	*1/**-	*1/**-	-	*1/**-	*1/**-
S-Link	-	YES	YES	-	YES	YES
Speaker output (W)	10W x 2	15W x 2	15W x 2	10W x 2	15W x 2	15W x 2
Power Consumption (W)						
In use (Max)	190W	200W	200W	190W	200W	200W
In Standby	2W	2W	2W	2W	2W	2W
Dimensions (W/H/D)						
(mm)		882 x 687 x 592 mm			975 x 757 x 633 mm	
(in)		34 3/4 x 27 x 23 1/4 in			38 3/8 x 29 13/16 x 24 15/16 in	
Mass						
(kg)		80 kg			107 kg	
(lbs)		176 lbs			236 lbs	

Television system

American TV standard, NTSC

Channel coverage

VHF:2-13 / UHF:14-69 / CATV:1-125

Picture tube

FD Trinitron® tube

Visible screen size

32-inch picture measured diagonally (KV-32FS10, 32FV15, 32XBR250, 34FV10, 34FV15, 34FV15C, 34FV15K, 34FV15T, 34FX250C)
36-inch picture measured diagonally (KV-36FS10, 36FV15, 36XBR250, 38FX250, 38FX250C, 38FX250T, 38FV15K)

Actual screen size

34-inch picture measured diagonally (KV-32FS10, 32FV15, 32XBR250, 34FV10, 34FV15, 34FV15C, 34FV15K, 34FV15T, 34FX250C)
38-inch picture measured diagonally (KV-36FS10, 36FV15, 36XBR250, 38FX250, 38FX250C, 38FX250T, 38FV15K)

Antenna

75 ohm external antenna terminal for VHF/UHF

Supplied accessories

Remote control RM-Y149A (KV-34FV15K, 38FV15K)
Remote control RM-Y168 (KV-32FS10, 34FV10, 36FS10)
Remote control RM-Y170 (KV-32XBR250, 34FX250C, 36XBR250, 38FX250, 38FX250C, 38FX250T)
Remote control RM-Y171 (KV-32FV15, 34FV15, 34FV15C, 34FV15T, 36FV15)
Battery size AA (R6) w/2

Design and specifications are subject to change without notice.

Notes:

- 1) 1 Vp-p 75 ohms unbalanced, sync negative
- 2) Y: 1 Vp-p 75 ohms unbalanced, sync negative
C: 0.286 Vp-p (Burst signal), 75 ohms
- 3) Y: 1.0 Vp-p, 75 ohms, sync negative; P_B: 0.7 Vp-p, 75 ohms;
P_R: Vp-p, 75 ohms
- 4) 500 mVrms (100% modulation), Impedance: 47 kilohms
- 5) More than 408 mVrms at the maximum volume setting (variable)
More than 408 mVrms (fix); Impedance (Output): 2 kilohms

Optional accessories

Connecting Cables:

RK-74A, VMC-810/820/830HG, VMC-10HG/30HG, VMC-720M, VMC-810S/820S, YC-15V/30V, YC-15/30HG, RK-G69HG, RKC-515HG

TV Stand: SU-32FD2, SU-36FD2, SU-32XBR2, SU-36XBR2

UV Mixer: EAC-66

(●) ® SRS (SOUND RETRIEVAL SYSTEM)

The (●) SRS (SOUND RETRIEVAL SYSTEM) is manufactured by Sony Corporation under license from SRS Labs, Inc. It is covered by U.S. Patent No. 4,748,669. Other U.S. and foreign patents pending.

The word 'SRS' and the SRS symbol (●) are registered trademarks of SRS Labs, Inc.

BBE and BBE symbol are trademarks of BBE Sound, Inc. and are licensed by BBE Sound, Inc. under U.S. Patent No. 4,638,258 and 4,482,866.

TABLE OF CONTENTS

<u>Section</u>	<u>Title</u>	<u>Page</u>	<u>Section</u>	<u>Title</u>	<u>Page</u>
	Warnings and Caution	3	6. DIAGRAMS		
	Safety Check Out Instructions	4	6-1. Block Diagram (1/5)		31
1. GENERAL			6-2. Block Diagram (2/5)		34
Connecting and Installing the TV		5	6-3. Block Diagram (3/5)		37
Basic Set Up		7	6-4. Block Diagram (UY PIP) (4/5)		40
Using Your TV		7	6-5. Block Diagram (UX PIP) (5/5)		41
Using the Wireless Headphones		8	6-6. Circuit Boards Location		42
Using Your Menus		9	6-7. Printed Wiring Boards and Schematic Diagrams		42
Operating Video Equipment		12	• A Board		43
Operating a Cable Box or DBS Receiver		12	• A Board Schematic Diagram		45
Troubleshooting		13	• AK Board		49
2. DISASSEMBLY			• C Board		53
2-1. Rear Cover Removal		14	• G Board		55
2-2. Chassis Assembly Removal		14	• GA Board		57
2-3. Service Position		15	• HA Board		57
2-4. Multi-Button Switch Removal		15	• HB Board		57
2-5. Picture Tube Removal		16	• HX Board		59
3. SET-UP ADJUSTMENTS			• T Board		59
3-1. Beam Landing		17	• UX Main Board		61
3-2. Convergence		18	• UX PIP Board		65
3-3. Focus		20	• UY Main Board		69
3-4. Screen (G2)		20	• UY PIP Board		73
3-5. White Balance Adjustments		20	• WA Board		75
4. SAFETY RELATED ADJUSTMENTS		21	6-8. Semiconductors		77
5. CIRCUIT ADJUSTMENTS		22	7. EXPLODED VIEWS		
5-1. Method of Setting the Service Adjustment Mode		22	7-1. Chassis		78
5-2. Memory Write Confirmation Method		22	7-2. Chassis		80
5-3. Adjust Buttons and Indicator		22	7-3. Picture Tube		81
5-4. Service Data		23	8. ELECTRICAL PARTS LIST		
			• Parts Listings		83

WARNINGS AND CAUTIONS

CAUTION!

AFTER REMOVING THE ANODE, SHORT CIRCUIT THE ANODE OF THE PICTURE TUBE AND THE ANODE CAP TO THE METAL CHASSIS, CRT SHIELD, OR CARBON PAINTED ON THE CRT.

WARNING!!

AN ISOLATION TRANSFORMER SHOULD BE USED DURING ANY SERVICE TO AVOID POSSIBLE SHOCK HAZARD, BECAUSE OF LIVE CHASSIS. THE CHASSIS OF THIS RECEIVER IS DIRECTLY CONNECTED TO THE AC POWER LINE.

SAFETY-RELATED COMPONENT WARNING!!

COMPONENTS IDENTIFIED BY SHADING AND MARK \triangle ON THE SCHEMATIC DIAGRAMS, EXPLODED VIEWS AND IN THE PARTS LIST ARE CRITICAL FOR SAFE OPERATION. REPLACE THESE COMPONENTS WITH SONY PARTS WHOSE PART NUMBERS APPEAR AS SHOWN IN THIS MANUAL OR IN SUPPLEMENTS PUBLISHED BY SONY. CIRCUIT ADJUSTMENTS THAT ARE CRITICAL FOR SAFE OPERATION ARE IDENTIFIED IN THIS MANUAL. FOLLOW THESE PROCEDURES WHENEVER CRITICAL COMPONENTS ARE REPLACED OR IMPROPER OPERATION IS SUSPECTED.

ATTENTION!

APRES AVOIR DECONNECTE LE CAP DE L'ANODE, COURT-CIRCUITER L'ANODE DU TUBE CATHODIQUE ET CELUI DE L'ANODE DU CAP AU CHASSIS METALLIQUE DE L'APPAREIL, OU AU COUCHE DE CARBONE PEINTE SUR LE TUBE CATHODIQUE OU AU BLINDAGE DU TUBE CATHODIQUE.

ATTENTION!!

AFIN D'EVITER TOUT RESQUE D'ELECTROCUTION PROVENANT D'UN CHASSIS SOUS TENSION, UN TRANSFORMATEUR D'ISOLEMENT DOIT ETRE UTILISE LORS DE TOUT DEPANNAGE. LE CHASSIS DE CE RECEPTEUR EST DIRECTEMENT RACCORDE A L'ALIMENTATION SECTEUR.

ATTENTION AUX COMPOSANTS RELATIFS A LA SECURITE!!

LES COMPOSANTS IDENTIFIES PAR UNE TRAME ET PAR UNE MARQUE \triangle SUR LES SCHEMAS DE PRINCIPE, LES VUES EXPLOSEES ET LES LISTES DE PIECES SONT D'UNE IMPORTANCE CRITIQUE POUR LA SECURITE DU FONCTIONNEMENT. NE LES REMPLACER QUE PAR DES COMPOSANTS SONY DONT LE NUMERO DE PIECE EST INDIQUE DANS LE PRESENT MANUEL OU DANS DES SUPPLEMENTS PUBLIES PAR SONY. LES REGLAGES DE CIRCUIT DONT L'IMPORTANCE EST CRITIQUE POUR LA SECURITE DU FONCTIONNEMENT SONT IDENTIFIES DANS LE PRESENT MANUEL. SUIVRE CES PROCEDURES LORS DE CHAQUE REMPLACEMENT DE COMPOSANTS CRITIQUES, OU LORSQU'UN MAUVAIS FONCTIONNEMENT SUSPECTE.

SAFETY CHECK-OUT

After correcting the original service problem, perform the following safety checks before releasing the set to the customer:

1. Check the area of your repair for unsoldered or poorly-soldered connections. Check the entire board surface for solder splashes and bridges.
2. Check the interboard wiring to ensure that no wires are "pinched" or contact high-wattage resistors.
3. Check that all control knobs, shields, covers, ground straps, and mounting hardware have been replaced. Be absolutely certain that you have replaced all the insulators.
4. Look for unauthorized replacement parts, particularly transistors, that were installed during a previous repair. Point them out to the customer and recommend their replacement.
5. Look for parts which, though functioning, show obvious signs of deterioration. Point them out to the customer and recommend their replacement.
6. Check the line cords for cracks and abrasion. Recommend the replacement of any such line cord to the customer.
7. Check the B+ and HV to see if they are specified values. Make sure your instruments are accurate; be suspicious of your HV meter if sets always have low HV.
8. Check the antenna terminals, metal trim, "metallized" knobs, screws, and all other exposed metal parts for AC Leakage. Check leakage as described below.

LEAKAGE TEST

The AC leakage from any exposed metal part to earth ground and from all exposed metal parts to any exposed metal part having a return to chassis, must not exceed 0.5 mA (500 microampere). Leakage current can be measured by any one of three methods.

1. A commercial leakage tester, such as the Simpson 229 or RCA WT-540A. Follow the manufacturers' instructions to use these instructions.
2. A battery-operated AC milliammeter. The Data Precision 245 digital multimeter is suitable for this job.
3. Measuring the voltage drop across a resistor by means of a VOM or battery-operated AC voltmeter. The "limit" indication is 0.75 V, so analog meters must have an accurate low voltage scale. The Simpson's 250 and Sanwa SH-63Trd are examples of passive VOMs that are suitable. Nearly all battery operated digital multimeters that have a 2V AC range are suitable. (See Fig. A)

HOW TO FIND A GOOD EARTH GROUND

A cold-water pipe is guaranteed earth ground; the cover-plate retaining screw on most AC outlet boxes is also at earth ground. If the retaining screw is to be used as your earth-ground, verify that it is at ground by measuring the resistance between it and a cold-water pipe with an ohmmeter. The reading should be zero ohms. If a cold-water pipe is not accessible, connect a 60-100 watts trouble light (not a neon lamp) between the hot side of the receptacle and the retaining screw. Try both slots, if necessary, to locate the hot side of the line, the lamp should light at normal brilliance if the screw is at ground potential. (See Fig. B)

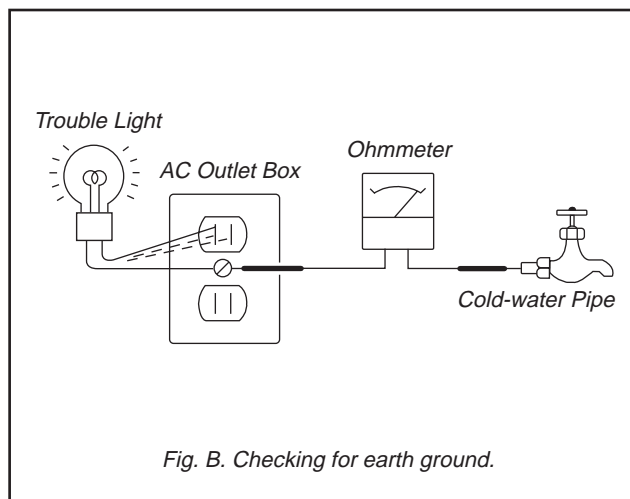
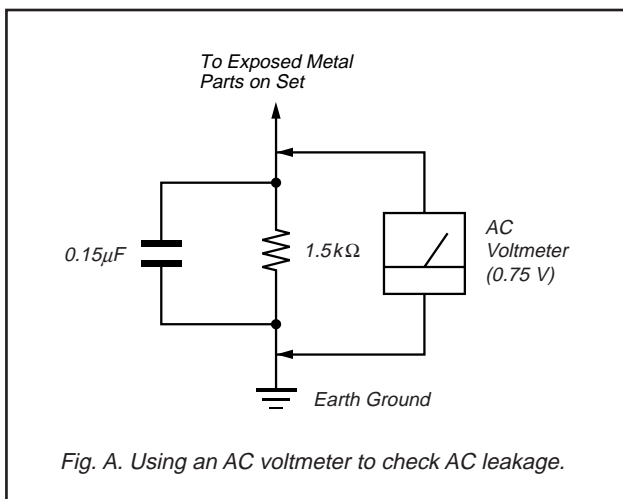

SECTION 1 GENERAL

The instructions mentioned here are partial abstracts from the Operating Instruction Manual. The page numbers shown reflect those of the Operating Instruction Manual.

Connecting and Installing the TV

Making Connections

Refer to the table below, it will direct you to the diagram suitable to the equipment you will be connecting.

If you will be connecting	See page
Cable or antenna only	3
Cable and antenna	3
Cable box	4
Cable box and cable to view scrambled channels	4
VCR and cable or antenna	5
VCR and cable box	5
Two VCRs for tape editing	6
Satellite Receiver	7
VCR and Satellite Receiver	7
DVD Player	8
DVD Player with component video output connectors	8
Audio system	9
Camcorder to view tapes	9
CONTROL S	10
VCR using S-Link	11
Satellite Receiver using S-Link	11

2

Connecting and Installing the TV (continued)

Cable Box Connections

Some pay cable TV systems use scrambled or encoded signals that require a cable box to view all channels.

Cable box

- 1 Connect the coaxial connector from your cable to the IN on your cable box.
- 2 Using a coaxial cable, connect OUT on your cable box to VHF/UHF on your TV.

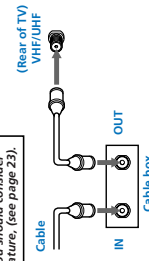

Cable box and cable

For this set up, you can switch between scrambled channels (through your cable box), and normal (CATV) channels by pressing ANT on your remote control.

Notes

- Your Sony remote control can be programmed to operate your cable box, (see page 31).
- When using PIP, you cannot view the AUX input in the window picture.

Tip

Pressing ANT switches between these inputs.

4

Note about the AC Power Cord

The AC power cord is attached to the rear of the TV with hooks. Use caution when removing the AC plug from its holder. Gently slide the cord in the upward direction, without removing the cord from the two lower hooks.

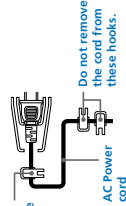

- A**
- VHF only or VHF/UHF or Cable

- B**
- VHF only or VHF/UHF or Cable

- C**
- VHF and UHF

Cable and antenna
If your cable provider does not feature local channels, you may find this set up convenient.



Select CABLE or antenna (ANT) mode by pressing ANT on the remote control.

Note

In order to receive channels with an antenna, you will need to turn your CABLE to OFF and perform the AUTO PROGRAM function, (see page 23).



3

VCR Connections

Connecting an antenna/cable TV system with a VCR

- 1 Attach the coaxial connector from your cable or antenna to IN on your VCR.
- 2 Using A/V connectors, connect AUDIO and VIDEO OUT on your VCR to AUDIO and VIDEO IN on your TV.
- 3 Using a coaxial connector, connect OUT on your VCR to VHF/UHF on your TV.

Tip

If you are connecting a manual VCR, connect only the single white audio output to the left input on your TV.

Connecting a VCR and TV with a cable box

- 1 Connect the coaxial cable from the wall to IN on your cable box.
- 2 Using a coaxial connector, connect OUT on your cable box to IN on your VCR.
- 3 Connect a coaxial cable (not supplied) from the OUT jack on your VCR to VHF/UHF on your TV.
- 4 Using A/V connectors, connect AUDIO and VIDEO OUT on your VCR to AUDIO and VIDEO IN on your TV.

For optimum picture quality, use S VIDEO instead of the yellow AV cable. S VIDEO does not provide audio, your audio connectors must still be connected.

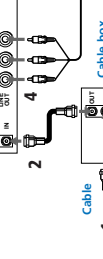
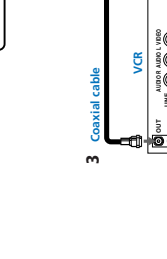
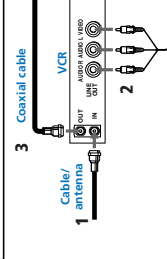

5

Connecting and Installing the TV (continued)

Connecting two VCRs for tape editing

MONITOR OUT gives you the ability to use a second VCR to record a program being played by the primary VCR or to perform tape editing and dubbing.

- 1 Connect the VCR intended for playback using the connection instructions on page 5 of this manual.
- 2 Using A/V connectors, connect AUDIO and VIDEO IN on your VCR intended for recording to MONITOR AUDIO and VIDEO OUT on your TV.

Note
You cannot record signals from equipment connected to the Y, Pb, Pr input.

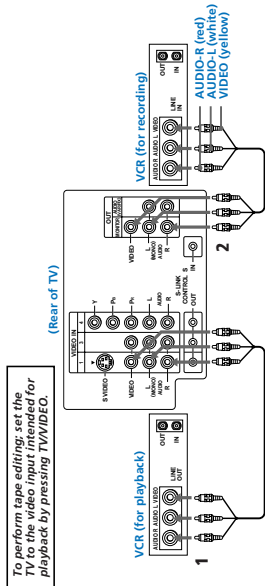

6

Connecting and Installing the TV (continued)

DVD Player Connections

Connecting a DVD Player

- 1 Using audio connectors, connect AUDIO OUT on your DVD player to AUDIO IN on your TV.
- 2 Using an S VIDEO cable, connect S VIDEO on your DVD player to S VIDEO on your TV.

Connecting a DVD Player with component video output connectors

Except KV-27FV15

This connection option offers the highest quality DVD picture.

- 1 Using AUDIO connectors, connect AUDIO R and L of the LINE OUT on your DVD player to AUDIO R and L on the VIDEO IN 4 panel at the rear of your TV.
- 2 Using three VIDEO connectors, connect Y, Pb, and Pr on the COMPONENT VIDEO OUT on your DVD player to Y, Pb, and Pr on the VIDEO IN 4 panel at the rear of your TV.

Note
Some DVD player terminals may be labeled Y, Cb, and Ck, or Y, B-Y, and R-Y. If so, connect them by matching the colors.

8

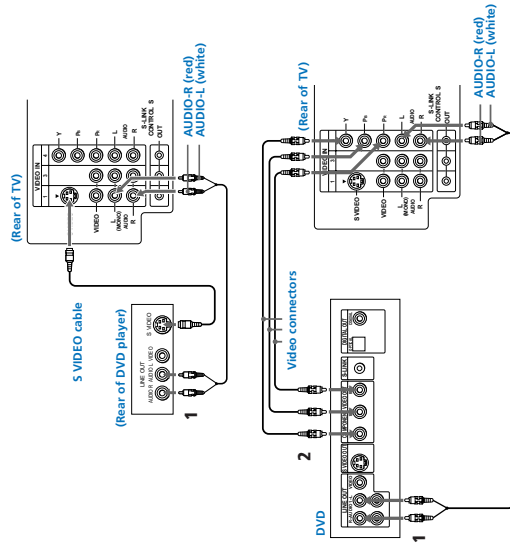

Satellite Receiver Connections

Connecting a satellite receiver

- 1 Connect the cable from your satellite antenna to SATELLITE IN on your receiver.
- 2 Attach the coaxial connector from your cable or antenna to VHF/UHF on your TV.
- 3 Using A/V connectors, connect AUDIO and VIDEO OUT on your receiver to AUDIO and VIDEO IN on your TV.

For optimum picture quality, use S VIDEO instead of the yellow A/V cable. S VIDEO does not require audio connectors, but audio connectors must still be connected.

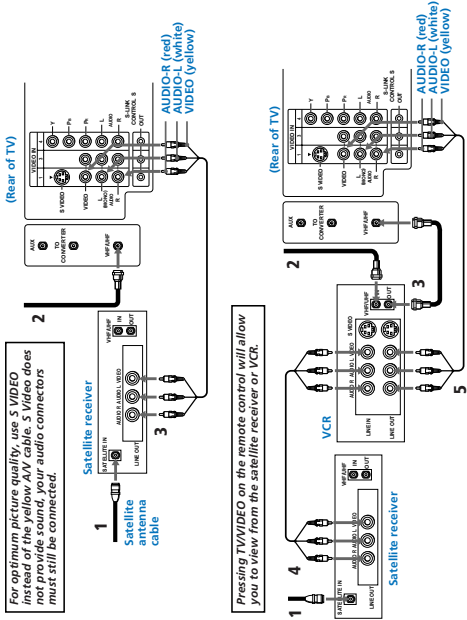

Connecting a satellite receiver and a VCR

- 1 Connect the cable from your satellite antenna to SATELLITE IN on your receiver.
- 2 Attach the coaxial connector from your cable or antenna to IN on your VCR.
- 3 Using a coaxial connector, connect OUT on your VCR to VHF/UHF on your TV.
- 4 Using A/V connectors, connect AUDIO and VIDEO OUT on your receiver to AUDIO and VIDEO IN on your VCR.
- 5 Using A/V connectors, connect AUDIO and VIDEO OUT on your VCR to AUDIO and VIDEO IN on your TV.

Pressing TV/VIDEO on the remote control will allow you to view from the satellite receiver or VCR.

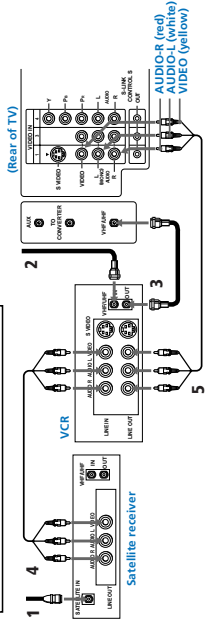

7

Additional Connections

Connecting an audio system

For an enhanced sound, connect your audio system to your TV.

- 1 Using AUDIO connectors, connect AUDIO OUT on your TV to one of the unused Line inputs (e.g. Tape-2, AUX1, etc.) on your stereo.
- 2 Set your stereo to the chosen Line input and use the AUDIO menu to set your audio output, (see page 20).

Connecting a camcorder

This connection is convenient for viewing a picture directly from your camcorder.

Using A/V connectors, connect AUDIO and VIDEO OUT on your camcorder to AUDIO and VIDEO IN on your TV.

Tip

If you are connecting a manual camcorder, connect only the single white audio output to the left input on your TV.

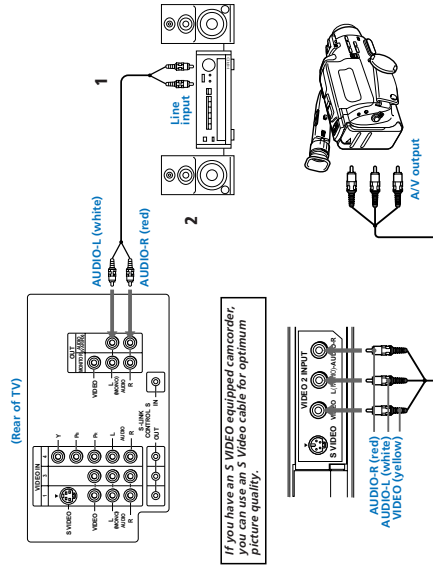

If you have an S VIDEO equipped camcorder, you can use an S Video cable for optimum picture quality.

Connecting an AV receiver

- 1 Using A/V cables, connect TV OUT on your TV to TV IN on your A/V receiver.
- 2 Using A/V cables, connect A/V OUT on your receiver to VIDEO IN on your TV.

Note

If you will be connecting your A/V receiver to external speakers, you do not need to connect AUDIO OUT on your A/V receiver to AUDIO IN on your TV.

Tip

You may want to use CHANNEL FIX to fix your TV's input to the A/V receiver (VIDEO 1). (see "CHANNEL SET UP" on page 26)

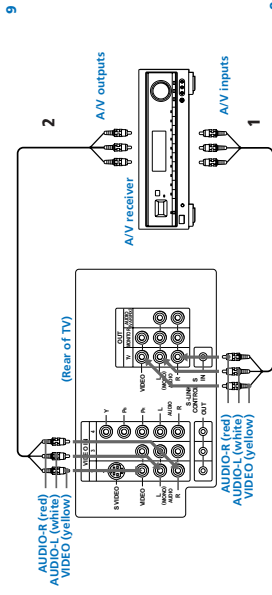

9

Using Special Sony Features

Using the CONTROL S feature

CONTROL S allows you to control your TV and other Sony equipment with one remote control.

Using the supplied CONTROL S cable, connect CONTROL S IN on your Sony equipment, (e.g. VCR) to CONTROL S OUT on your TV.

Tip

You can also program your remote control to operate other equipment, (see page 34).

Using the Vertical Compression feature

These models use a feature called "vertical compression" to achieve maximum picture quality on widescreen sources, including selected DVDs. This feature compresses the height of each line for a higher resolution of the picture.

To enjoy this feature, set your Sony DVD player to 16:9 mode. The widescreen source will be automatically detected and displayed with maximum picture quality.

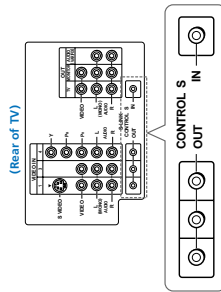

Connecting S-Link to a VCR

KV-27FV15, 32FV15, 36FV15 only
S-Link automatically powers on the TV and switches to the correct video input when a tape is inserted in the VCR.

- Using A/V connectors, connect AUDIO and VIDEO OUT on your VCR to AUDIO and VIDEO IN on your TV.
- Using an S-Link connector (mono mini plug), connect S-LINK on your VCR to S-LINK/CONTROL S-OUT in the same VIDEO IN column on your TV.

Connecting S-Link to a satellite receiver

KV-27FV15, 32FV15, 36FV15 only

When you power on the satellite receiver, S-Link automatically powers on the TV and switches to the correct video input.

- Using A/V connectors, connect AUDIO and VIDEO OUT on your satellite receiver to AUDIO and VIDEO IN on your TV.
- Using an S-Link connector (mono mini plug), connect S-LINK on your satellite receiver to S-LINK/CONTROL S-OUT in the same VIDEO IN column on your TV.

Note

The S-Link feature will override the "SKIP" VIDEO LABEL input, (see page 22).

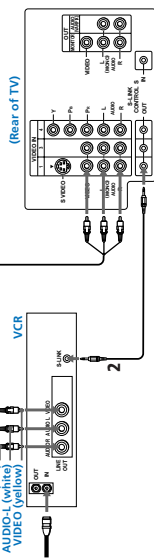

The S-Link connector must be in the same VIDEO-IN column as the connected A/V cables.

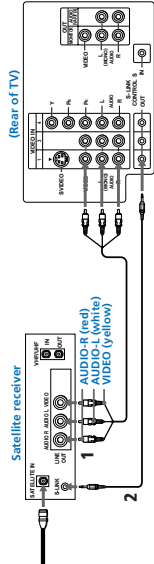

11

11

Basic Set Up

Inserting batteries

Insert two size AA (R6) batteries (supplied) by matching the + and - on the batteries to the diagram inside the battery compartment.



Notes

- Remove the batteries to avoid damage from possible battery leakage whenever you anticipate that the remote control will not be used for an extended period.
- Handle the remote control with care. Avoid dropping it, getting it wet, or placing it in direct sunlight, near a heater, or where the humidity is high.
- Your remote control can be programmed to operate most video equipment, (see page 29).

Using the remote control move & select buttons

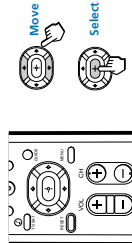

The supplied remote control has "arrow" buttons (Move, Select) which allow for movement of the on-screen cursor. Pressing on the outer buttons will cause the cursor to move in the corresponding direction. Pressing the center-button (Select) will select the item.

Front panel menu control

The front panel menu controls allow access to the on-screen menus without the use of a remote control. Pressing the MENU button will bring up the on-screen menus. The arrow buttons, (Move, Select) move the on-screen cursor in the menus and the (Select) button selects the menu item.

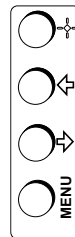

Using Your New TV

Setting up the TV automatically

After you have finished connecting your TV, you will want to run AUTO PROGRAM to set up your channels.

The AUTO PROGRAM feature does not apply for installations that use a cable box for all channel selection.

Tips

- Perform this function during the day, with the antenna and/or cable properly connected, to ensure that all available channels will be broadcasting and receivable.
- If your cable or antenna is connected to AUX, press ANT and AUX appears next to the channel number.

Using the buttons on the top of the TV:



- Press POWER to turn on the TV. The initial setup screen appears.



POWER

- Press CH + to run AUTO PROGRAM or press CH - to exit.



-CHANNEL -

Tip

To reset your TV to factory settings, turn the TV on. Then, while pressing the RESET button on your remote control, press the POWER button on your TV. The TV will turn itself off, then back on.

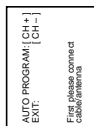

AUTO PROGRAM (CH+) EXT.
First please connect cable/antenna

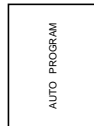

AUTO PROGRAM

12

13

Using Your New TV (continued)

Watching the TV

The following chart explains more advanced buttons on your remote control.

REFER TO THE ILLUSTRATION OF THE REMOTE CONTROL ON THE INSIDE FRONT COVER OF THIS MANUAL AS YOU REVIEW THIS CHART

CONTROL SYMBOL	POWER	FUNCTION	VIDEO SOURCE	TV	VIDEO MODE	VIDEO	VIDEO	VIDEO	SOUND	SLEEP	MUTE
Using the White Labeled Buttons for TV Operations	Press when you want to turn connected equipment on and off.	Press when you want to control connected equipment with your remote control, (see pages 29-31 for instructions on programming your remote control).	Use for direct channel selection. Press 0-9 to select a channel, the channel will change after 2 seconds, or you can press ENTER for immediate selection.	Cycles through the VIDEO MODE settings: VIVID, SPORTS, MOVIE, STANDARD.	Alternates back and forth between the last two channels selected with the 0-9 keys.	Instantly turns off the sound. Press again or press VOL + to restore sound.	Turns the TV off in approximately 30, 60, or 90 minutes. Cancel by pressing until SLEEP OFF appears.	Press to return to factory settings while in the on-screen menus.			

14

Using Your New TV (continued)

Using Picture-in-Picture – PIP

KV-27FV15, 32FV15, 36FV15 only
These models are equipped with dual tuners. This means that PIP is "ready to use".

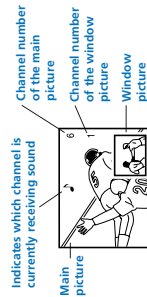

Notes

- You must press TV (FUNCTION) before you can control PIP with the yellow labeled buttons.
- The AUX input cannot be viewed in the window picture.

16

Using the White Labeled Buttons for TV Operations

DISPLAY	Press once to display current time (if set) and channel number. Press again to access current CAPTION VCR ON setting. To cancel, press DISPLAY until DISPLAY OFF appears.
TV/VIDEO	Press repeatedly to cycle through available video inputs: TV, VIDEO 1, VIDEO 2, VIDEO 3 and VIDEO 4
AUX (AUX input)	Press to change the VHF/UHF input to the AUX input.
TV/VR +	Press when you are finished using a VCR and you want to switch to the TV input. Your VCR power will remain on.
MUTE/SAP	Cycles through the Multi-channel TV Sound (MTS) options: STEREO, SAP (Second Audio Program), MONO (see page 20).
SYSTEM OFF	Powers off all Sony equipment at once. This feature may not work with older Sony equipment.
TV/VR	Cycles through the available audio settings.

15

Using the Wireless Headphones

Setting Up the Headphones

Install the supplied size AA (R6) battery into the headphones.

- Open the battery compartment lid by pressing and sliding the lid as illustrated.



- Lift the cover and insert the battery into the compartment with the positive side up and then close the lid.

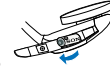

Notes

- When used continuously, the battery will last:
 - up to 40 hours with alkaline batteries.
 - up to 20 hours with manganese batteries.
- Replace the battery with a new one when the sound becomes weak.

18

Tip

For optimal sound reception, do not cover the infrared transmitter on the TV or the infrared sensors on the headphones.

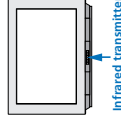

Notes

- To help prevent possible hearing damage due to sudden or prolonged excessive volume, do not set the headphone volume too high while using them.
- To prevent possible damage to the infrared transmitter in the television, please press the MUTE button to turn off the headphone feature when the headphones are not in use.

Using the Headphones

- Press the MODE button. The 1 icon and channel number are displayed.

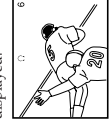

- Turn the power on by placing the headphones securely on your head.

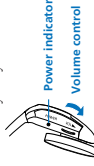

- If you only want to listen to the sound from the cordless headphones, turn down the TV speaker volume, or press MUTE. To turn off the headphones, remove them from your head and press MUTE.

Using Your Menus

Learning menu selection

Use the MENU button to access a menu and use the arrow buttons (← or →) to alter settings. Use the following example, in which we activate the CABLE, to learn how to modify settings.

- Press the MENU button. The main menu appears.
- Press ← or → to highlight the desired menu (in this case SET UP), and press → to select it.



Coverage Area of the Infrared Rays

This diagram illustrates the approximate area covered by the infrared rays emitted from the transmitter.

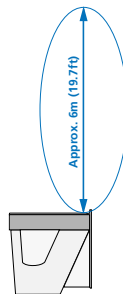

Notes

- If you use the headphones too far from the TV, you may hear a hissing noise.
- If something is between the headphones and the TV, the sound may be interrupted. These problems are inherent to IR communication and do not reflect a problem with the TV.

Press (⏏) again to switch the audio to the window picture.

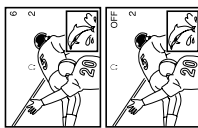

Notes

- Exiting from PIP will return the sound to the main picture.
- The audio to the headphones will be automatically turned off when the TV is powered off.

Listening to Sound from a Main/PIP Picture

If you want to listen to the sound from the main or window picture through your headphones, select the audio source.

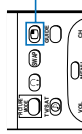

- Press (⏏) to display a window picture.
- Press (⏏). The ⏏ display and channel number appears for about three seconds.

Main Picture audio

Using Your Menus (continued)

Quick start to the menus

The following is a guide to your menus.

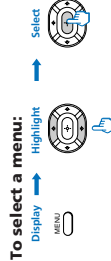

Note
Menus shown are for KV-36FV15; your menus may not look exactly like those illustrated.

	The VIDEO menu will allow you to make adjustments to your picture settings. It will also allow you to customize the picture MODE based on the type of program you are viewing.
	The AUDIO menu offers enhanced audio options such as listening to second audio programming (SAP), or customizing the EFFECT of the sound on your TV.
	The TIMER menu sets the clock on your TV and allows you to program your TV for scheduled viewing using the ON/OFF TIMER.
	The SET UP menu provides several options for setting up your channels, labeling your TV/VIDEO inputs, and selecting the LANGUAGE of your menus.
	The CHANNEL SET UP menu is a sub-menu which provides further options for setting up your TV.
	The Basic Menu provides quick access to frequently used settings.

3 Press ← or → to move to the desired option and press (⏏).



4 Press ← or → to move to the desired feature and press (⏏). Options for your selection will be highlighted.



Tip

Pressing MENU on the remote control will allow you to exit from the menus at any time.

Using the VIDEO menu



To select the VIDEO menu:

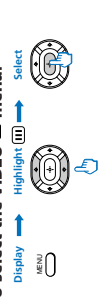

MODE <i>Customized picture viewing</i>	VIVID: Select for enhanced picture contrast and sharpness. SPORTS: Select for a bright picture. MOVIE: Select for a finely detailed picture. STANDARD: Select to receive a standard picture. <i>Press the PICTURE MODE button to access one of the above settings directly.</i>
PICTURE <i>Picture contrast</i>	Adjust left to decrease picture contrast and soften the color. Adjust right to increase picture contrast and create more vivid color.
BRIGHTNESS <i>Picture adjustment</i>	Adjust left to darken the picture. Adjust right to brighten the picture.
COLOR <i>Color saturation</i>	Adjust left to decrease color intensity or saturation. Adjust right to increase color intensity or saturation.
HUE <i>Color tones</i>	Adjust left to increase the red tones. Adjust right to decrease the red tones.
SHARPNESS <i>Picture detail</i>	Adjust left to soften the picture detail. Adjust right to sharpen the picture detail.
TRINITONE <i>White intensity adjustment</i>	HIGH: Gives the white colors a blue tint. MEDIUM: Gives the white colors a neutral tint. NTSC STD: Gives the white colors a red tint.
COLOR CORRECT <i>Color ratio adjustment</i>	ON: Emphasizes reds and blues. OFF: Emphasizes greens.

Using Your Menus (continued)

Using the AUDIO menu



To select the AUDIO menu:



Tips

- Press **⏪** to cycle through your AUDIO options.
- Press MTS/SAP on your remote control to cycle through the MTS options.

TREBLE	Adjust left or right to decrease or increase higher pitched sound.
BASS	Adjust left or right to decrease or increase low pitched sounds.
BALANCE	Adjust left or right to emphasize left and right speaker balance.
AUTO VOLUME <i>Stabilizes volume</i>	(KV-27FV15, 32FV15, 38FV15 only) ON: Select to stabilize the volume. OFF: Select to turn AUTO VOLUME off.
EFFECT <i>Enhanced audio</i>	SIMULATED: Adds a surround-like effect to mono programs. SRS: Produces a dynamic three dimensional sound for stereo signals. OFF: Normal stereo or mono reception.
MTS <i>Multi-Channel sound</i>	MONO: Select to reduce noise in areas with poor reception. SAP: Select to listen to bilingual broadcast or other Second Audio Programs (SAP). STEREO: Select when viewing a broadcast in stereo.
SPEAKER <i>Custom selection of audio output source</i>	ON: Select to listen to the sound from the TV speakers with or without a separate stereo system. OFF: Select to turn off the TV speakers and listen to the TV's sound only through external audio system speakers.
AUDIO OUT <i>Use to control the TV's volume through a stereo</i>	AUDIO OUT can only be set when SPEAKER is set to OFF . VARIABLE: Adjust the volume through your TV. FIXED: Adjust the TV volume through a connected stereo.

Using Your Menus (continued)

Using the SET UP menu



To select the SET UP menu:



Note

The FAVORITE CHANNEL feature is not available for the AUX input.

CHANNEL SET UP	The CHANNEL SET UP menu is a submenu which provides further options for setting up your TV. (see page 23)
PARENTAL CONTROL	The PARENTAL CONTROL feature provides parents several options for programming the TV to block shows based on their rating. (see pages 25-28).
VIDEO LABEL <i>Label connected equipment for easy recognition</i>	With the VIDEO LABEL window open: 1 Press ⏪ or ⏩ to access the input you want to label and press ⏪ or ⏩ to choose the label and press ⏪ . VIDEO LABEL Options: VIDEO1/2/3: VHS, 8mm, BETA, LD, GAME, SAT, DVD, WEB, RECEIVER, DTV, SKIP VIDEO4: DTV, TV, SKIP If you select SKIP, your TV will skip this connection when you press the TV/VIDEO button.
CAPTION VISION <i>Closed Captioning and channel information</i>	CC1, 2, 3 or 4: Displays a printed version of the dialog or sound effects of a program, (the mode should be set to CC1 for most programs). TEXT1, 2, 3 or 4: Displays network/station information presented using either half or the whole screen. XDS (Extended Data Service): Displays network name, program name, program length, and time of the show if the broadcaster offers this service.
LANGUAGE	Select from available languages to display all menus in your language of choice.
TILT CORRECTION	Press ⏪ or ⏩ to correct any tilt of the picture between +5 and -5 and press ⏪ .
DEMO	Select to run a demonstration of on-screen menus.

Using the TIMER menu



To select the TIMER menu:



Tips

Set DAYLIGHT SAVING before setting the clock.

DAYLIGHT SAVING	YES: Select to compensate for Daylight Saving Time. NO: Select at the end of Daylight Saving Time.
CURRENT TIME SET <i>Necessary for the ON/OFF TIMER</i>	With the CURRENT TIME SET menu open: 1 Press ⏪ or ⏩ until the current day is displayed. 2 Press ⏪ or ⏩ until the current hour and AMPM is displayed. Press ⏪ or ⏩ to select. 3 Press ⏪ or ⏩ until the current minute is displayed, and press ⏪ . 4 Press ⏪ or ⏩ until the current minute is displayed, and press ⏪ . Any loss of power will cause these settings to be cleared.
ON/OFF TIMER <i>Wake up or scheduled viewing</i>	CURRENT TIME SET must be programmed before you can use the ON/OFF TIMER. With the ON/OFF TIMER menu open: 1 Choose the ON/OFF TIMER you would like to set and press ⏪ . 2 Press ⏪ or ⏩ until the desired day or range of days is displayed. Press ⏪ or ⏩ to select. 3 Indicate the time that you want the TV to turn on (hour, then minutes) by pressing ⏪ or ⏩ and then ⏪ . Set the time duration (maximum of 6 hours) by pressing ⏪ or ⏩ and then ⏪ . 4 Press ⏪ or ⏩ until you reach the desired channel. Press ⏪ or ⏩ to select. When you perform AUTO PROGRAM , all ON/OFF TIMER settings will be cleared.

Using the CHANNEL SET UP menu



To select the CHANNEL SET UP menu:



Note

Your remote control can be programmed to operate your cable box. (see page 31)

FAVORITE CHANNEL <i>Quick access to favorite channels</i>	Setting FAVORITE CHANNEL: 1 Press ⏪ then ⏪ to select AUTO or MANUAL . (Selecting AUTO will display the last five channels chosen with the more control's 0-9 buttons.) 2 Press ⏪ or ⏩ to move the cursor to 1, 2, 3, 4 or 5 and press ⏪ . 3 Press ⏪ or ⏩ to access the desired channel and press ⏪ . To preview your favorite channels in the window picture, set PREVIEW to ON . Using FAVORITE CHANNEL: 1 Exit all menus and press ⏪ , your FAVORITE CHANNEL options will appear. 2 Press ⏪ or ⏩ to access the channel you want to watch, and press ⏪ . For KV-27FV15, 32FV15, 38FV15 only If PREVIEW is set to ON , a window picture displays your favorite channels as you cycle through the options.
CABLE	ON: Select if you are receiving cable channels with a CATV cable. You will need to run AUTO PROGRAM after changing your CABLE settings. OFF: Select if you are using an antenna.
CHANNEL FIX <i>Useful when you have a cable box or satellite receiver connected</i>	2-6: Select when you want to control all channel selection through a cable box. Select the appropriate channel number (usually 3 or 4) and use the cable box's remote control for selection. AUX 2-6: Select when a cable box is connected to the AUX input, (see page 4). Press the AUX button to alternate between. VIDEO: Select from available video inputs when you have video equipment connected (e.g. satellite receiver) and you want your TV fixed to it.
AUTO PROGRAM	Instructs the TV to program all receivable channels.

Using Your Menus (continued)

CHANNEL SKIP/ADD With the CHANNEL SKIP/ADD window open: <ol style="list-style-type: none"> 1 Select the desired channel. 2 Press CD to SKIP or ADD (only one option will be available). 	CHANNEL SKIP/ADD 33 ADD Use IP or CH (1-1) to select the channel. Move ⏪ Select ⏩ Exit ⏹
CHANNEL CAPTION Label up to 12 channels with their call letters	CHANNEL CAPTION 33 CHANNEL Move ⏪ Select ⏩ Exit ⏹

Using Your Menus (continued)

ENGLISH RATINGS For Canadian programs that are broadcast in English	Overview of the Ratings (Canadian models only) C: All children C8+: Children 8, years and older G: General programming PG: Parental Guidance 14+: Viewers 14 and older 18+: Adult programming	ENGLISH RATINGS C8+ - PG - 14+ - 18+ - S: MENU Move ⏪ Select ⏩ Exit ⏹
FRENCH RATINGS For Canadian programs that are broadcast in French	(Canadian models only) G: General programming 13 ans+: Not recommended for under 13 16 ans+: Not recommended for ages under 16 18 ans+: Programming restricted to adults	FRENCH RATINGS G - 13 ans+ - 16 ans+ - 18 ans+ - S: MENU Move ⏪ Select ⏩ Exit ⏹
U.S.A. RATINGS For programs from the United States	(Canadian models only) Please see TV RATINGS on page 25 for information on U.S.A. RATINGS.	

The Parental Guideline Rating System

This table provides a brief overview of the ratings systems available for the PARENTAL CONTROL feature.

For detailed information on how to change your TV rating, see pages 27-28.

Notes

- The content ratings will increase depending on the level of the age-based rating. For example, a program with a TV-PG-V (Violence) rating may contain moderate violence, while a TV-14-V (Violence) rating may contain more intense violence.
- If you choose to block unrated TV programs, please be aware that the following programs may be blocked: emergency broadcasts, political programs, sports, news, public service announcements, religious programs and weather.

TV RATINGS Block programs by their rating, content or both	Overview of the Ratings Age based options: TV-Y: All children. TV-Y7: Directed to older children. TV-G: General Audience. TV-14: Parents strongly cautioned. TV-MA: Mature Audience only. Content based options: FV: Fantasy Violence. S: Strong Language. L: Sexual Situations. V: Violence.	TV RATINGS TV-Y - TV-Y7 - TV-G - TV-14 - TV-MA - S: MENU Move ⏪ Select ⏩ Exit ⏹
MOVIE RATINGS	(U.S. models only) G: All children. TV-PG: Directed to older children. PG-13: General Audience. R: Parental Guidance suggested X: 17: No one under 17 admitted. X: No one under 17 admitted.	MOVIE RATINGS PG - PG-13 - R - No-17 - X: MENU Move ⏪ Select ⏩ Exit ⏹
UNRATED Block programs or movies that are broadcast without a rating	(U.S. models only) VIEW ALL: Allows all unrated programming. BLOCK TV: Blocks all unrated TV programs. BLOCK MOVIE: Blocks all unrated movies. BLOCK ALL: Blocks all unrated programming.	CUSTOM MENU TV RATINGS UNRATED VIEW ALL S: MENU Select category Move ⏪ Select ⏩ Exit ⏹

Using the PARENTAL CONTROL menu

This section shows you how to access the PARENTAL CONTROL menu. After you follow the example below, the next section shows you how to adjust your TV's rating.

- 1 Press MENU and select the SET UP menu.



- 2 Point the cursor to PARENTAL CONTROL and press **⏩**.

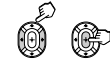

You will be asked to enter a 4-digit password for any future access into the PARENTAL CONTROL menu.

- 3 Press **⏩** and use the 0-9 buttons to enter your 4-digit password.

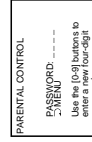

- 4 Confirm your password by entering it again.

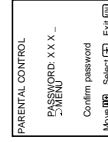

Once your password is set correctly, you will be taken into the PARENTAL CONTROL menu.

In order to change the RATING you will need to set PARENTAL LOCK to ON.

- 5 Point the cursor at PARENTAL LOCK and press **⏩**. Press **⏩** or **⏪** to ON and press **⏩**.

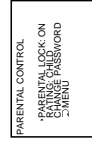

See pages 25-26 for an overview of the Parental Guideline ratings.

Tip

Keep this instruction manual in a safe place. In the event that you forget your password, please see page 33.

Using Your Menus (continued)

Setting the TV's RATING

This section provides information on how to set the TV's RATING and how to change your password.

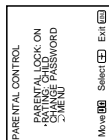

PARENTAL LOCK <i>Turns ratings on/off</i>	ON: Select to activate the RATING. OFF: Turns off current ratings.
RATING	If you are not familiar with the Parental Guideline rating system, you should use one of the following preselcted categories to help simplify the rating selection. The following maximum ratings will be allowed: CHILD (TV-14, G, U.S. models only). YOUTH (TV-PG, PG (U.S. models only). TV-PG, PG, 8 plus (Canadian models only). YOUNG ADULT (TV-14, PG-13 (U.S. models only), TV-14, 14+, 13 ans+ (Canadian models only). <div style="border: 1px solid black; padding: 2px; width: fit-content;"> PARENTAL CONTROL PARENTAL LOCK ON RATING CHANGE PASSWORD Exit </div>
CHANGE PASSWORD	CUSTOM: If you prefer to set more restrictive ratings, highlight CUSTOM and press ⏏ . See pages 25-26, for an overview of the rating systems available. In the CUSTOM RATINGS menu: 1 Select the desired rating category and press ⏏ . 2 Press ⬆ or ⬇ to select the maximum rating or content and press ⏏ . 3 Press ⬆ or ⬇ to block or unblock the rating or content and press ⏏ . Once you have blocked a rating or content, all higher ratings or contents will be automatically blocked. To view a blocked program: Press ENTER on the remote control, then use the 0-9 buttons to enter your password. To reset your password: 1 Move the cursor to CHANGE PASSWORD press ⏏ . 2 Use the 0-9 buttons to create a new password, enter again to confirm. <i>In the event that you forget your password, see page 33.</i>

Note

Entering your password to view a blocked program will temporarily turn PARENTAL LOCK to OFF. To reactivate your PARENTAL CONTROL settings, turn the TV off then back on; the TV will restore your rating settings.

Operating Video Equipment (continued)

Laserdisc

- In some rare cases, you may not be able to operate your non-Sony video equipment with the supplied remote control. In this case, please use the equipment's own remote control.
- When you remove the batteries, the code number may revert to the factory setting.
- The code numbers for Sony VCRs are assigned at the factory as follows:

Manufacturer	Code
Sony	701
Panasonic	704, 710
Pioneer	702
RCA	752
Toshiba	754

Manufacturer	Code
Sony	751
Panasonic	753
Pioneer	752
RCA	755
Toshiba	754

Manufacturer	Code
Sony	701
Panasonic	704, 710
Pioneer	702
RCA	752
Toshiba	754

Manufacturer	Code
Sony	751
Panasonic	753
Pioneer	752
RCA	755
Toshiba	754

Manufacturer	Code
Sony	751
Panasonic	753
Pioneer	752
RCA	755
Toshiba	754

Manufacturer	Code
Sony	751
Panasonic	753
Pioneer	752
RCA	755
Toshiba	754

Operating Video Equipment

Programming the remote

You can use the supplied remote control to operate Sony or non-Sony video equipment.

- Press **CODE SET**.
- Press **VTR/DVD** (FUNCTION).
- Use the **0-9** buttons to key in the manufacturer's code number from the following chart.
- Press **ENTER**.

VCR code numbers

Manufacturer	Code
Sony	301, 302, 303
Admiral (M. Ward)	308, 309, 310
Alina	308, 309, 310
Audio Dynamic	308, 309, 310
Bio sonic	308, 309, 310
Chizen	308, 309, 310
Chigo	308, 309, 310
Criterion	308, 309, 310
Curtis Mathes	308, 309, 310
Daewoo	308, 309, 310
Dynaco	308, 309, 310
Dynalab	308, 309, 310
Emerson	308, 309, 310
Fisher	308, 309, 310
Funai	308, 309, 310
General Electric	308, 309, 310
Go Video	308, 309, 310
Goldstar	308, 309, 310

Operating a Cable Box or Satellite Receiver

Programming the remote control

You can program the supplied remote control to operate a cable box or satellite receiver.

- Press **CODE SET**.
- Press **SAT/CABLE** (FUNCTION).
- Use the **0-9** buttons to key in the manufacturer's code number from the following chart.
- Press **ENTER**.

For more details on operating the cable box or satellite receiver

Refer to the operating instructions that were supplied with the equipment.

Hiachi	314, 336, 338, 337
Instant Replay	309, 305, 304, 306, 308
JVC	314, 336, 337, 345, 346, 347
Kenwood	314, 336, 337, 345, 346, 347
Lexi (Sears)	314, 336, 337, 345, 346, 347
Magnavox	314, 336, 337, 345, 346, 347
Marianz	314, 336, 337, 345, 346, 347
Mitsubishi	314, 336, 337, 345, 346, 347
Multitech	314, 336, 337, 345, 346, 347
NEC	314, 336, 337, 345, 346, 347
Olympic	314, 336, 337, 345, 346, 347
Panasonic	314, 336, 337, 345, 346, 347
Philco	314, 336, 337, 345, 346, 347
Philips	314, 336, 337, 345, 346, 347
Pioneer	314, 336, 337, 345, 346, 347
Quasar	314, 336, 337, 345, 346, 347
RCAPROSCAN	314, 336, 337, 345, 346, 347
Realistic	314, 336, 337, 345, 346, 347
Samsung	314, 336, 337, 345, 346, 347
Sanyo	314, 336, 337, 345, 346, 347
Scott	314, 336, 337, 345, 346, 347
Shinrom	314, 336, 337, 345, 346, 347
Signature 2000 (M. Ward)	314, 336, 337, 345, 346, 347
SV2000	314, 336, 337, 345, 346, 347
Sylvania	314, 336, 337, 345, 346, 347
Symphonic	314, 336, 337, 345, 346, 347
Tashio	314, 336, 337, 345, 346, 347
Tatung	314, 336, 337, 345, 346, 347

Buttons on the remote control

To turn on or off	Press VTR/DVD (POWER).
To select a channel directly	Press the 0-9 buttons.
To change channels	Press CH +/- .
To record	Press ▶ and ● simultaneously.
To play	Press ▶ .
To stop	Press ■ .
To fast forward	Press ▶▶ .
To rewind the tape	Press ◀◀ .
To pause	Press .
To resume normal playback, press again or press ▶ .	Press ▶▶ or ◀◀ during playback.
To scan	To resume normal playback, release the button.
To change input mode	Press TV/VR .

If the remote control doesn't work

First, try repeating the setup procedures using the other codes listed for your equipment.

- Tips**
 - If more than one code number is listed, try entering them one by one until you come to the correct code for your equipment.
 - If you enter a new code number, the code number you previously entered at that setting is erased.
 - In some rare cases, you may not be able to operate your equipment with the supplied remote control. In this case, use the equipment's supplied remote control.
 - Whenever you remove the batteries the code numbers may revert to the factory setting.

Cable box code numbers

Manufacturer	Code
Huflin/Kogal	222, 223, 224, 225, 226
Jerold/G. I.	201, 202, 203, 204, 205, 206, 207, 208, 218
Oak	227, 228, 229
Panasonic	219, 220, 221
Pioneer	214, 215
Scientific Atlanta	209, 210, 211
Tecum	216, 217
Zenith	212, 213

Satellite receiver code numbers

Manufacturer	Code
Sony	801 (preset code for remote control)
General Electric	802
Hiachi	805
Hughes	804
Panasonic	803
RCA/PROSCAN	802, 808
Toshiba	806, 807

Consult the table below; it suggests solutions to specific problems.

Problem	What it could be	What you can do
You want to restore the TV's factory settings		<ul style="list-style-type: none"> First, turn the TV on. Then while pressing the RESET button on the remote control, press the POWER button on the TV. The TV will turn itself off and then back on. When the TV turns on again, all settings will be reset, and the initial setup screen will appear. Call your local Sony service center.
A red light keeps flashing on the TV for more than a few seconds	<ul style="list-style-type: none"> Your TV may need service. 	
TV makes a noise when turned on	<ul style="list-style-type: none"> This is a normal function of your TV. 	
Screen is not lit and there is no sound	<ul style="list-style-type: none"> Power cord may not be plugged in. Remote control batteries may not be inserted correctly. TV/VIDEO setting may be incorrect. Current program may exceed PARENTAL CONTROL settings. 	<ul style="list-style-type: none"> Check your power cord. Re-insert the batteries in your remote control. Press TV/VIDEO until you receive a channel. Check your PARENTAL CONTROL settings. (page 28).
Poor or no picture (screen lit), good sound	<ul style="list-style-type: none"> VIDEO menu settings may not be adjusted correctly. Antenna/cable connectors may be faulty. VIDEO LABEL inputs may be set to WEB. (This label darkens the screen for ideal WebTV viewing) 	<ul style="list-style-type: none"> Readjust your VIDEO menu settings. (page 19). Check your VIDEO LABEL settings. (page 22).
Good picture, no sound	<ul style="list-style-type: none"> Sound may be set to MUTING. Your TV may be set to SAP. SPEAKER may not be set correctly. 	<ul style="list-style-type: none"> Press MUTING. Check the MTS setting in the AUDIO menu. (page 20). Check your SPEAKER settings. (page 20).
No color	<ul style="list-style-type: none"> Color settings may not be adjusted correctly. 	<ul style="list-style-type: none"> Adjust the COLOR settings in the VIDEO menu. (page 19).
Only snow and noise appear on the screen	<ul style="list-style-type: none"> CABLE may not be set correctly in the CHANNEL SET UP menu. Antenna/cable connections may not be correct. TV may be set to AUX mode. 	<ul style="list-style-type: none"> Ensure that you have selected the correct CABLE mode in the CHANNEL SET UP menu. (page 23). Press ANT on your remote control to change the input mode. (page 15).

Supplied accessories

Remote control RM-Y168 (KV-32FS10, 36FS10 only), RM-Y171 (KV-27FV15, 32FV15, 36FV15 only)(1)
Batteries size AA (R6) (2)

Optional accessories

Connecting cables
RK-714, RK-G69HG, VMC-10HG,
VMC-720M, VMC-810S/820S, YC-15V/
30V
TV Stand SU-27FD2, SU-32FD2, SU-36FD2
U/V mixer EAC-66

Problem	What it could be	What you can do
Cannot receive upper channels (UHF) when using an antenna	<ul style="list-style-type: none"> CABLE setting may not be correct in the CHANNEL SET UP menu. 	<ul style="list-style-type: none"> Ensure that CABLE is set to OFF in the CHANNEL SET UP menu. (page 23). Use AUTO PROGRAM to add receivable channels that are not presently in TV memory. (page 23).
Cannot receive any channels when using cable	<ul style="list-style-type: none"> CABLE setting may not be correct in the CHANNEL SET UP menu. 	<ul style="list-style-type: none"> Ensure that CABLE is set to OFF in the CHANNEL SET UP menu. (page 23). Use AUTO PROGRAM to add receivable channels that are not presently in TV memory. (page 23). Use the remote control supplied with the cable box.
Cannot gain enough volume when using a cable box	<ul style="list-style-type: none"> Volume may not be adjusted on your cable box. 	<ul style="list-style-type: none"> Use the remote control supplied with the cable box.
TV is fixed to one channel	<ul style="list-style-type: none"> CHANNEL FIX settings may not be correct. 	<ul style="list-style-type: none"> Check your CHANNEL FIX settings. (page 23).
Lost password for PARENTAL CONTROL		<ul style="list-style-type: none"> In the password screen, enter the following master password: 4357. The master password cannot be used to unlock currently blocked channels.

After reading these operating instructions, you have additional questions related to the use of your product, please contact your nearest Sony service center at 1-800-222-SONY (669)(U.S. residents only) or (416) 499-SONY (669)(Canadian residents only).

SECTION 2 DISASSEMBLY

2-1. REAR COVER REMOVAL

(KV-32FS10/32FV15/32XBR250/34FV10
34FV15/34FV15C/34FX250C/34FV15K/34FV15T)

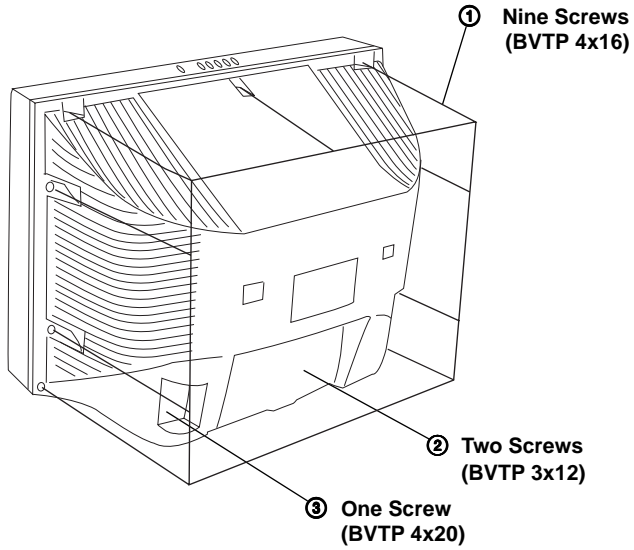

(KV-36FS10/36FV15/36XBR250
38FX250/38FX250C/38FX250T/38FV15K)

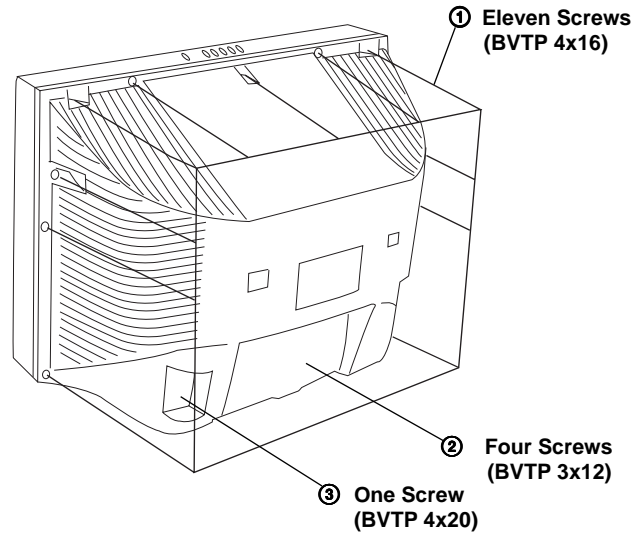

2-2. CHASSIS ASSEMBLY REMOVAL

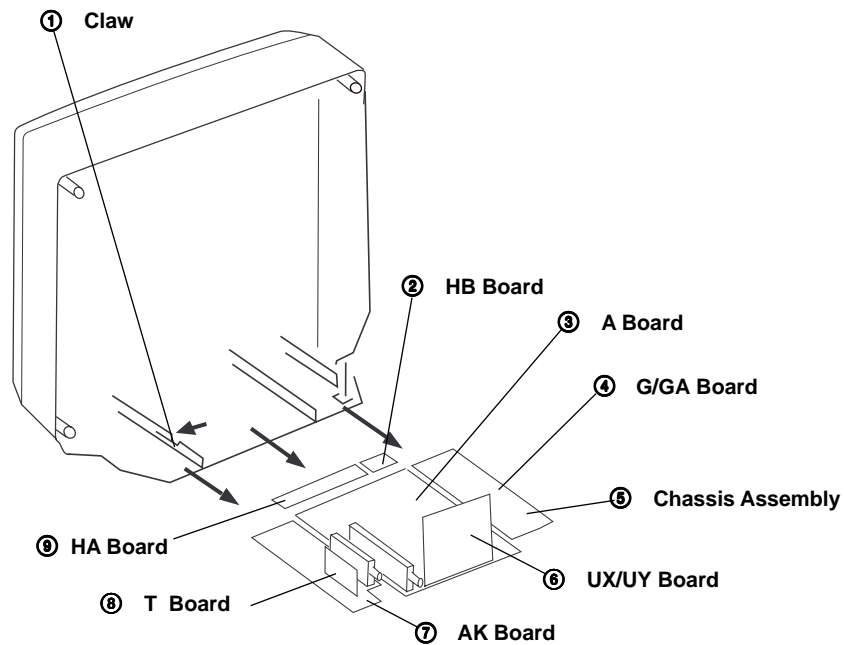

2-3. SERVICE POSITION

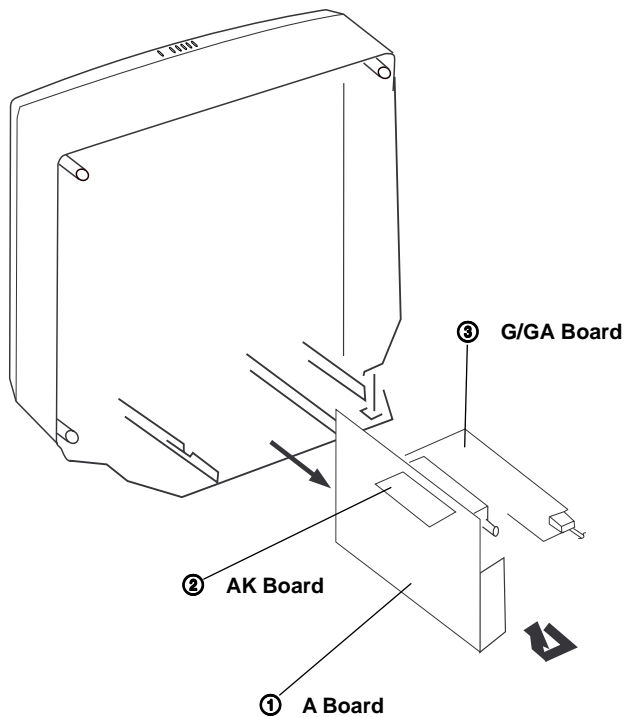

2-4. MULTI-BUTTON SWITCH REMOVAL

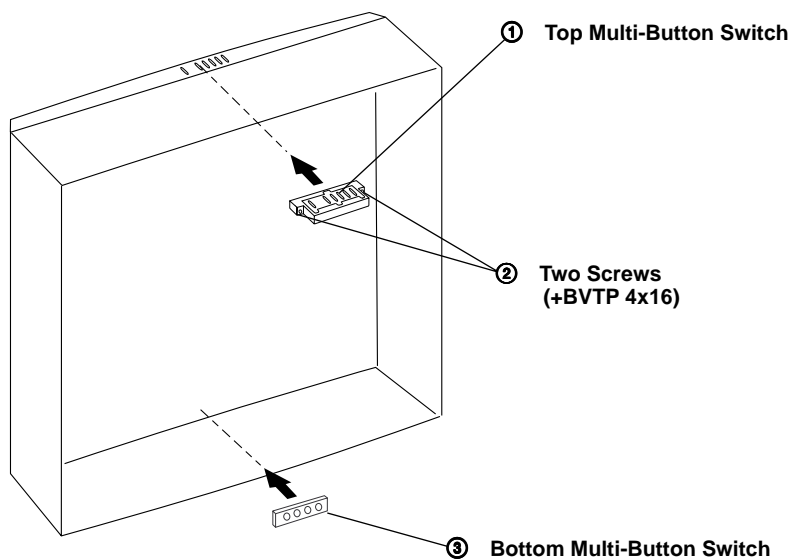

2-5. PICTURE TUBE REMOVAL

WARNING -- Before removing anode-cap:

High voltage remains in the CRT even after the power is disconnected.

To avoid electrical shock, discharge CRT before attempting to remove the anode-cap. Short between anode and coated earth ground strap of CRT.

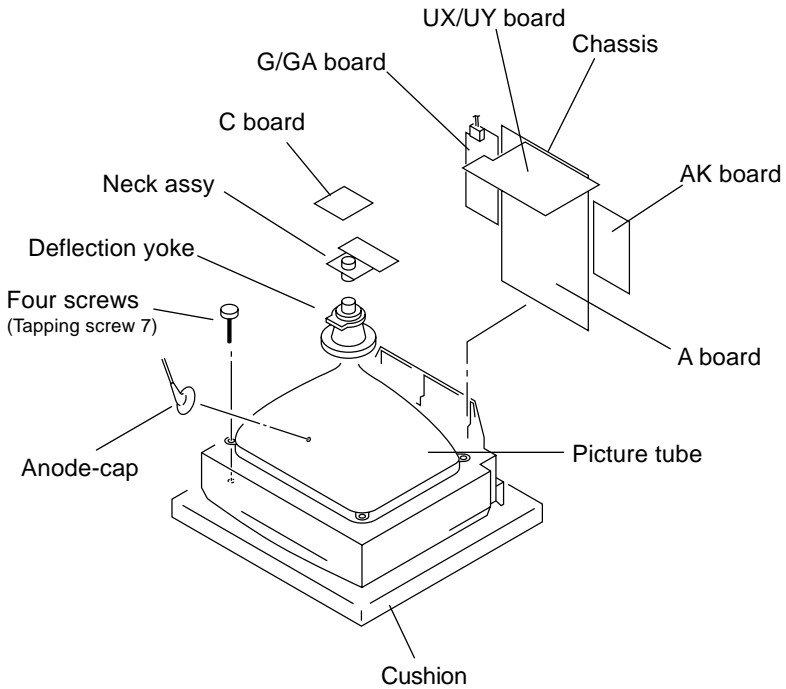
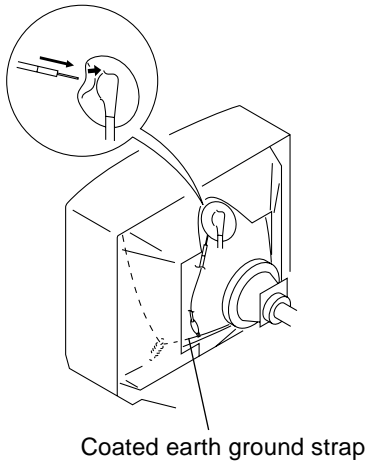

ANODE-CAP REMOVAL

WARNING: High voltage remains in the CRT even after the power is disconnected. To avoid electrical shock, discharge CRT before attempting to remove the anode-cap. Short between anode and coated earth ground strap of CRT.

NOTE: After removing the anode, short circuit the anode of the picture tube and the anode cap to either the metal chassis, CRT shield, or carbon painted on the CRT.

REMOVAL PROCEDURES

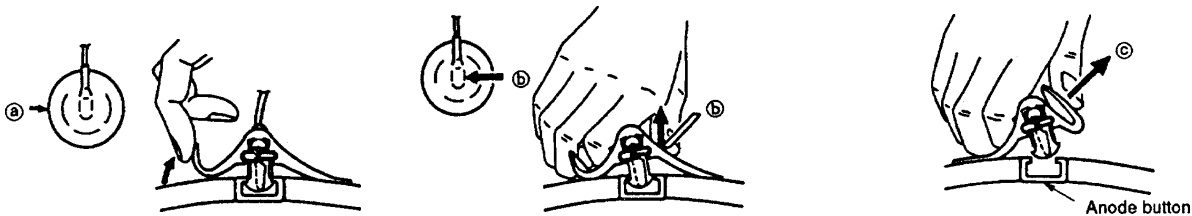

- ① Turn up one side of the rubber cap in the direction indicated by arrow ①.
- ② Use your thumb to pull the rubber cap firmly in the direction indicated by arrow ②.
- ③ When one side of the rubber cap separates from the anode button, the anode-cap can be removed by turning the rubber cap and pulling it in the direction of arrow ③.

HOW TO HANDLE AN ANODE-CAP

- ① Do not use sharp objects which may cause damage to the surface of the anode-cap.
- ② Do not squeeze the rubber covering too hard to avoid damaging the anode-cap. A material fitting called a shatter-hook terminal is built into the rubber.
- ③ Do not force turn the foot of the rubber cover. This may cause the shatter-hook terminal to protrude and damage the rubber.

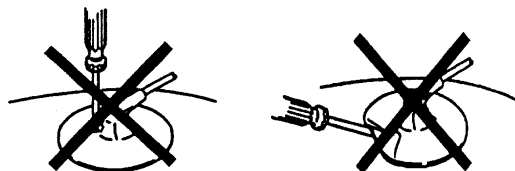

SECTION 3 SET-UP ADJUSTMENTS

The following adjustments should be made when a complete realignment is required or a new picture tube is installed.

These adjustments should be performed with rated power supply voltage unless otherwise noted.

The controls and switch should be set as follows unless otherwise noted:

PICTURE control normal

BRIGHTNESS control normal

Perform the adjustments in order as follows:

1. Beam Landing
2. Convergence
3. Focus
4. Screen (G2)/White Balance

Note: Test Equipment Required:

1. Color Bar Pattern Generator
2. Degausser
3. DC Power Supply
4. Digital Multimeter
5. Oscilloscope
6. CRT Analyzer

3-1. BEAM LANDING

Preparation:

- Input a white pattern signal.
- Face the picture tube in an East or West direction to reduce the influence of geomagnetism.

NOTE: Do not use the hand degausser because it magnetizes the CRT .

1. Input white pattern from pattern generator.
2. Loosen the deflection yoke mounting screw, and set the purity control to the center as shown below:

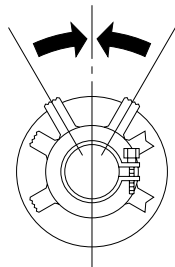

3. Input green pattern from pattern generator.
4. Move the deflection yoke backward, and adjust with the purity control so that green is in the center and red and blue are even on both sides.

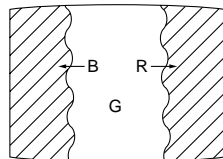

5. Move the deflection yoke forward, and adjust so that the entire screen becomes green.

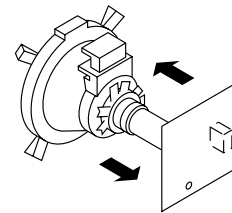

6. Switch over the raster signal to red and blue and confirm the condition.
7. When the position of the deflection yoke is determined, tighten it with the deflection yoke mounting screw.
8. When landing at the corner is not right, adjust by using the disk magnets.

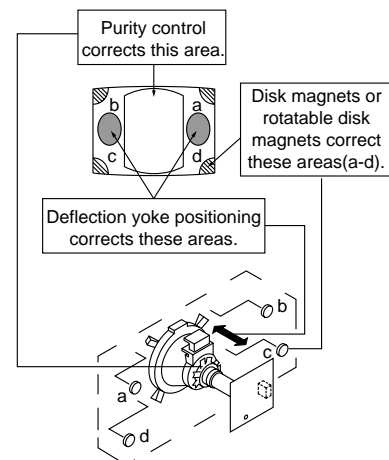

3-2. CONVERGENCE

Preparation:

- Before starting, perform FOCUS, V. LIN and V. SIZE adjustments.
- Set BRIGHTNESS control to minimum.
- Input dot pattern.

(1) Vertical and Horizontal Static Convergence

1. Adjust V. STAT magnet to converge red, green and blue dots in the center of the screen. (Vertical movement)

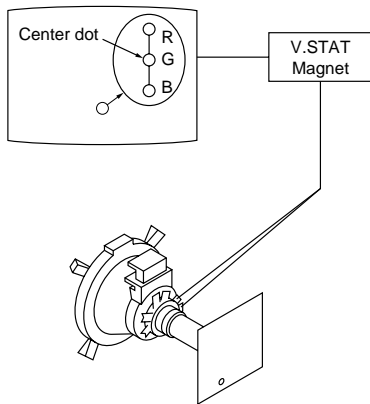

Tilt the V. STAT magnet and adjust static convergence to open or close the V. STAT magnet.

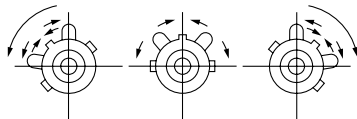

2. When the V. STAT magnet is moved in the direction of arrow (a) and (b), red, green, and blue dots move as shown below:

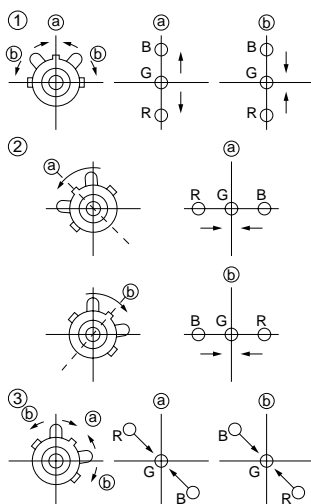

Operation of BMC (Hexapole) Magnet

The respective dot positions resulting from moving each magnet interact, so perform adjustment while tracking.

Use the VSTAT tabs to adjust the red, green, and blue dots so they line up at the center of the screen (move the dots in a horizontal direction.)

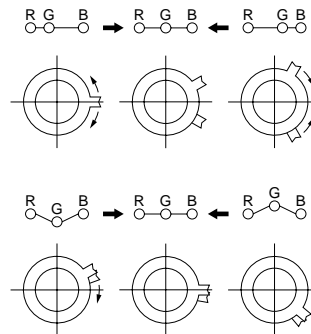

Y Separation Axis Correction Magnet Adjustment

1. Input cross-hatch pattern, adjust PICTURE to minimum and BRIGHTNESS to normal.
2. Adjust the deflection yoke upright so it touches the CRT.
3. Adjust so that the Y separation axis correction magnet on the neck assembly is symmetrical from top to bottom (open state).

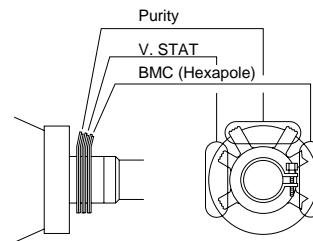

4. Return the deflection yoke to its original position.

(2) Dynamic Convergence Adjustment

- Before starting, perform Horizontal and Vertical Static Convergence Adjustment.
1. Slightly loosen deflection yoke screw.
 2. Remove deflection yoke spacers.
 3. Move the deflection yoke for best convergence as shown below:

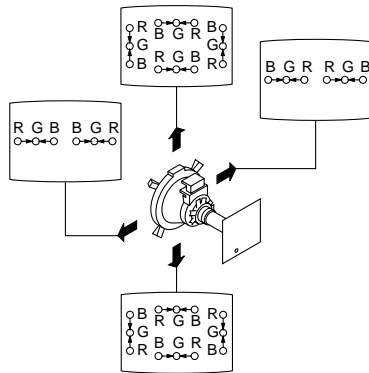

4. Tighten the deflection yoke screw.
5. Install the deflection yoke spacers.

(3) Screen-corner Convergence

Affix a permalloy assembly corresponding to the misconverged areas:

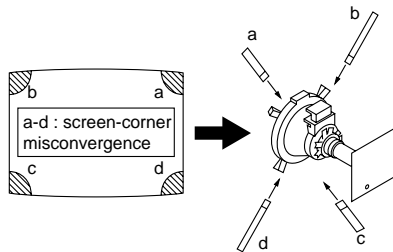

(4) TLH Plate Adjustment

- Input crosshatch pattern
- Adjust PICTURE QUALITY to standard, PICTURE and BRIGHTNESS to 50%, and OTHER to standard.
- Adjust the Horizontal Convergence of red and blue dots by tilting the TLH plate on the deflection yoke.

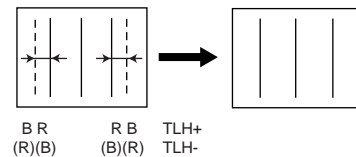
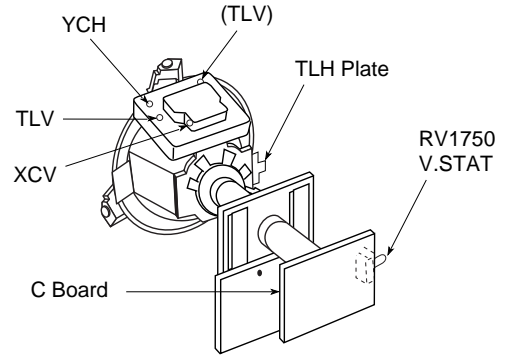

1. Adjust XCV core to balance X axis.
2. Adjust YCH VR to balance Y axis.
3. Adjust vertical red and blue convergence with VTILT (TLV VR.)

Perform adjustments while tracking items 1 and 2.

(5) H Center SW Adjustment

- Before adjusting H Center SW (S501, S502), make sure that HPOS data is "7".

3-3. FOCUS

1. Input Monoscope signal.
2. Set user controls to normal.
3. Set Video mode to STANDARD.
4. Set the PICTURE to maximum.
5. Adjust FOCUS control for best picture at center circle.
6. Then receive an entire white signal. Make sure Magenta Ring is at acceptable level

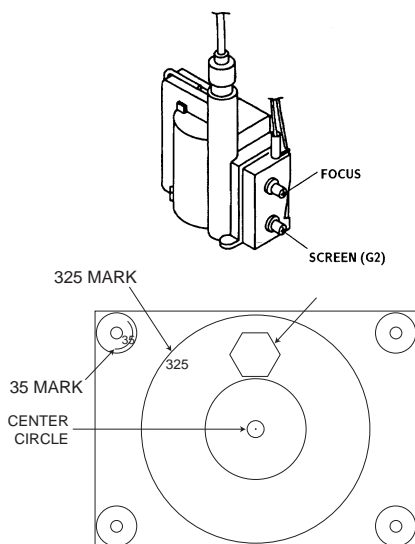

3-4. SCREEN (G2)

1. Input signal from the pattern generator.
2. Set the user controls to NORMAL.
3. Attach the G2-Jig to the C Board.
4. Adjust RCUT, GCUT, BCUT, and SBRT in service mode with an oscilloscope so that voltages on the red, green, and blue cathodes are 170 ± 2 V DC.
5. Observe the screen and adjust SCREEN (G2) VR to obtain the fairly visible background of dot signal.
6. Push the TEST +JUMP (+ Channel) to cut off the signal, then the screen is bright or dark. Brightness of raster must be increased when adjusting.

7. Adjust screen VR until the screen is just cut off, or scarcely lights up. A signal cannot be seen when the brightness of the raster is high.
8. Push the JUMP again to release the cut off.

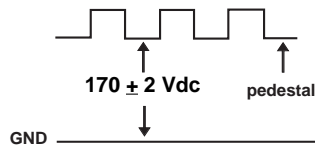

3-5. WHITE BALANCE ADJUSTMENTS

NO.	Disp.	Item	All Models
24	RDRV	Red Drive	31
25	GDRV	Green Drive	31
26	BDRV	Blue Drive	31
27	RCUT	Red Cut-off	7
28	GCUT	Green Cut-off	7
29	BCUT	Blue Cut-off	7
38	SBRT	Sub Bright	7

1. Set program palette to "STANDARD" and push "RESET".
2. Input an entire white signal.
3. Set to Service adjustment Mode.
4. Set the PICTURE and BRIGHT to minimum.
5. Adjust with SBRT if necessary.
6. Set RCUT to "14".
7. Select GCUT and BCUT with **1** and **4**.
8. Adjust with **3** and **6** for the best white balance.
9. Set the PICTURE and BRIGHT to maximum.
10. Select GDRV and BDRV with **1** and **4**.
11. Adjust with **3** and **6** for the best white balance.
12. Write into the memory by pressing **MUTING** then **ENTER** **.

NOTE:

White Balance should be adjusted after Sub Contrast because RDRV is also used in Sub Contrast adjustment. (See page 29)

SECTION 4 SAFETY RELATED ADJUSTMENTS

☒ R530, R531 CONFIRMATION METHOD (HOLD-DOWN CONFIRMATION) AND READJUSTMENTS

Always perform the following adjustments when replacing the following components marked with a ☒ mark on the schematic diagram:

A BOARD: IC355, IC501, D302, D519, D520, D521, C531, C532, Q301, R356, R359, R361, R387, R529, R530, R531, R532, R533, R550, T503

G BOARD (KV-32FS10, 32FV15, 32XBR250, 36FS10, 36FV15, 36XBR250): IC643, R661
GA BOARD (KV-34FV10, 34FV15, 34FV15C, 34FV15K, 34FV15T, 34FX250C, 38FV15K, 38FX250, 38FX250C, 38FX250T): IC6003, R6088

Step 1 Preparation before Confirmation

Turn the POWER switch ON.

Input a white signal and set the PICTURE and BRIGHT controls to maximum.

Confirm that, when the set is operating normally, the voltage at check terminal TP85 is more than 23.0 V DC.

At AC input: 120.0 ± 2.0 VAC

Step 2

Input a white signal and verify that I ABL is within the specified range: $2062.5 \pm 100 \mu\text{A}$,
+B = 135.5 ± 1 VDC .

At AC input: 120.0 ± 2.0 VAC

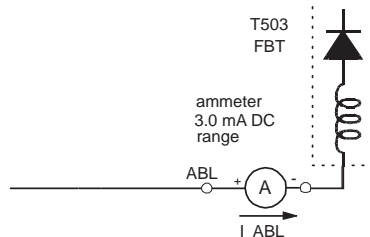

Step 3

Record the voltage between TP85 and ground.

Step 4

Using an external DC power supply, apply voltage between TP85 and ground.

Increase the voltage gradually and confirm that the hold-down works (raster disappears) at lower than the voltage recorded in Step 3.

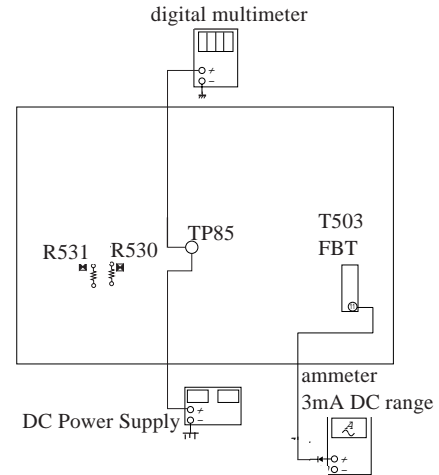

32" Lower than $26.95 \pm (-0.1)$ V DC.

At AC input: 120.0 ± 2.0 VAC

36" Lower than $22.05 \pm (-0.1)$ V DC.

At AC input: 120.0 ± 2.0 VAC

A BOARD - CONDUCTOR SIDE

Step 5

Confirm that a voltage appears between TP85 and ground, of more than 23.0 V DC.

At AC input: 120.0 ± 2.0 VAC

B+ VOLTAGE CONFIRMATION AND ADJUSTMENT

Always perform the following adjustments when replacing the following components marked with ☒ on the schematic diagram:

G BOARD (KV-32FS10, 32FV15, 32XBR250, 36FS10, 36FV15, 36XBR250): IC643, R661
GA BOARD (KV-34FV10, 34FV15, 34FV15C, 34FV15K, 34FV15T, 34FX250C, 38FV15K, 38FX250, 38FX250C, 38FX250T): IC6003, R6088

- 1) Using Variac, apply AC input voltage: 130.0 ± 2.0 VAC
- 2) Input a monoscope signal.
- 3) Set the PICTURE control and the BRIGHT control to initial reset value.
- 4a) (G Board Models) Confirm the voltage of G Board CN641 between pin ① to ground on "G" PWB is less than 136.5 ± 1.0 V DC.
- 4b) (GA Board Models) Confirm the voltage of GA Board CN6007, between pin ① to ground on "GA" PWB is less than 136.5 ± 1.0 V DC.
- 5a) (G Board Models) If step 4a is not satisfied, replace R661 and repeat the above steps.
- 5b) (GA Board Models) If step 4b is not satisfied, replace R6088 and repeat the above steps.

SECTION 5 CIRCUIT ADJUSTMENTS

ELECTRICAL ADJUSTMENT BY REMOTE COMMANDER

Use Remote Commander (RM-Y149A, RM-Y168, RM-Y170, RM-Y171) to perform the following circuit adjustments:

NOTE : Test Equipment Required:

1. Pattern Generator
2. Frequency Counter
3. Digital Multimeter
4. Audio OSC

5-1. Method of Setting the Service Adjustment Mode

SERVICE MODE PROCEDURE

1. Standby mode. (Power off)
2. **DISPLAY** → **5** → **VOL (+)** → **POWER** on the Remote Commander.
(Press each button within a second.)

SERVICE ADJUSTMENT MODE IN

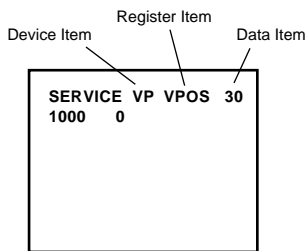

3. The CRT displays the item being adjusted.
4. Press **2** or **5** on the Remote Commander to select the device item.
5. Press **1** or **4** on the Remote Commander to select the item.
6. Press **3** or **6** on the Remote Commander to change the data.
7. If you want to recover the latest values press **0** then **ENTER** to read the memory.
8. Press **MUTING** then **ENTER** to write into memory**.

NOTE: If the NVM is replaced, perform test and reset, then download from microprocessor to NVM to prevent loss of picture.

SERVICE ADJUSTMENT MODE MEMORY

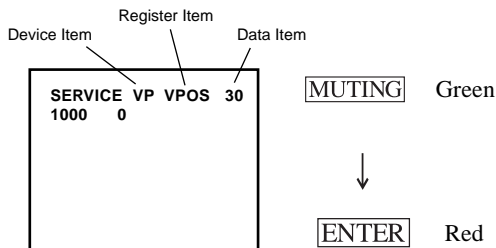

9. Press **8** then **ENTER** on the Remote Commander to reset.

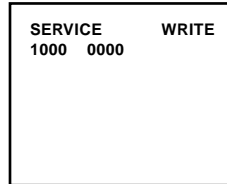

Carry out step 9) when adjusting IDs 0 to 4 and when replacing and adjusting IC102.

Factory original setting

10. Turn set off and on to exit.

5-2. Memory Write Confirmation Method

1. After adjustment, pull out the plug from the AC outlet, then replace the plug in the AC outlet again.
2. Turn the power switch ON and set to Service Mode.
3. Call the adjusted items again to confirm they were adjusted.

5.3. Adjust Buttons and Indicator

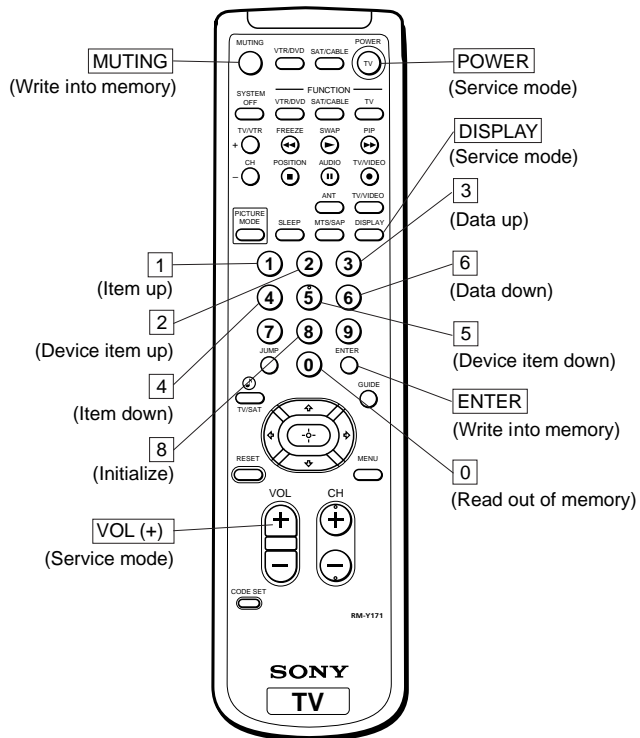

RM-Y171

****WARNING:** Do NOT turn off the power or AC immediately after pressing **MUTING** then **ENTER**. Wait at least 10 seconds.

5-4. Service Data

No.	Register Name	Description	Data Range	Adj/Fix	Initial Data	Average Data**	Comments
						All Models	
VP CXA2131S							
1	HPOS	Horizontal Position Adjust	0-31	Fix	7	7	
2	HSIZ	Horizontal Amp Adjust	0-31	Fix	10	10	
3	VBOW	VRT Line Bowing Adjust	0-15	Fix	6	6	
4	VANG	VRT Line Bow Slant Adjust	0-15	Fix	5	5	
5	TRAP	Horizontal Trapezoid Adjust	0-15	Fix	6	6	
6	PAMP	Horizontal Pin Distort Adjust	0-63	Fix	32	32	
7	UCPN	Upper Pin	0-63	Fix	36	36	
8	LCPN	Lower Pin	0-63	Fix	36	36	
9	VSIZ	Vertical Amplitude Adjust	0-63	Fix	0	0	
10	VPOS	Vertical Position Adjust	0-63	Fix	31	31	
11	VLIN	Vertical Linearity Adjust	0-15	Fix	7	7	
12	VSCO	S-Correction	0-15	Fix	7	7	
13	VZOM	16:9 CRT Z Mode On/Off	0,1	Fix	0	0	
14	EHT	VRT High Volt Correction	0-15	Fix	4	4	
15	ASP	Aspect Ratio Control	0-63	Fix	47	47	
16	SCRL	16:9 CRT Z Mode Tran Scroll	0-63	Fix	31	31	
17	HBSW	HBLK SW	0,1	Fix	1	1	
18	LBLK	Left Screen H Blk Control	0-15	Fix	15	15	
19	RBLK	Right Screen H Blk Control	0-15	Fix	0	0	
20	HDW	H Drive Pulse Width	0,1	Fix	1	1	
21	EWDC	EW/DC Adjust	0,1	Fix	0	0	
22	LVLN	Screen Bottom VRT Lin Adjust	0-15	Fix	0	0	
23	UVLN	Screen Top VRT Lin Adjust	0-15	Fix	0	0	
24	RDRV	R Output Drive Control	0-63	Adj	31	31	
25	GDRV	G Output Drive Control	0-63	Adj	31	31	
26	BDRV	B Output Drive Control	0-63	Adj	31	31	
27	RCUT	R Output Cutoff Control	0-15	Adj	7	7	
28	GCUT	G Output Cutoff Control	0-15	Adj	7	7	
29	BCUT	B Output Cutoff Control	0-15	Adj	7	7	
30	RDR4	Video 4 R Output Drive Control	0-63	Adj	31	31	
31	GDR4	Video 4 G Output Drive Control	0-63	Adj	31	31	
32	BDR4	Video 4 B Output Drive Control	0-63	Adj	31	31	
33	RCU4	Video 4 R Output Cutoff Control	0-15	Adj	7	7	
34	GPU4	Video 4 G Output Cutoff Control	0-15	Adj	7	7	
35	BCU4	Video 4 B Output Cutoff Control	0-15	Adj	7	7	
36	SHUE	Sub Hue	0-31	Adj	15	15	
37	SCOL	Sub Color	0-31	Adj	15	15	
38	SBRT	Sub Brightness	0-63	Fix	15	15	
39	RON	R Output On/Off	0,1	Fix	1	1	
40	GON	G Output On/Off	0,1	Fix	1	1	
41	BON	B Output On/Off	0,1	Fix	1	1	
42	AXPL	Axis Pal	0,1	Fix	0	0	
43	CBPF	Chroma BPF On/Off	0,1	Fix	1	1	
44	COFF	Color On/Off	0,1	Fix	0	0	
45	KOFF	Set Color Killer	0,1	Fix	0	0	
46	SSHP	Sub Sharpness	0-15	Fix	7	7	
47	SHPF	Sharpness Circuit F0	0,1	Fix	1	1	
48	PREL	Pre/Over-Shoot Switching	0,1	Fix	1	1	
49	Y-DC	DC Trans Ratio Switching	0,1	Fix	1	1	
50	ABLM	ABL Mode Switching	0,1	Fix	1	1	
51	YDEL	Y Delay Time Control	0-15	Fix	7	7	
52	NCOL	No Color ID	0,1	Fix	1	1	
53	FSC	FSC Out On/Off	0,1	Fix	1	1	
54	K-ID	Killer ID	0,1	Fix	1	1	
55	HOSC	H VCO Oscillation Frequency	0-15	Fix	7	7	
56	VSS	V Sync Slice Level	0,1	Fix	0	0	
57	HSS	H Sync Slice Level	0,1	Fix	0	0	
58	HMSK	H Mask	0,1	Fix	1	1	
59	VTMS	Select Signal VTIM Pin	0-3	Fix	0	0	

Service Data (cont.)

No.	Register Name	Description	Data Range	Adj/Fix	Initial Data	Average Data**		Comments
						All Models		
VP CXA2131S <i>continued</i>								
60	AFC	AFC Loop Gain	0-3	Fix	0	0		
61	FIFR	Field Frequency	0-3	Fix	3	3		
62	REFP	REFP	0,1	Fix	0	0		
63	VBSW	VBW	0-3	Fix	0	0		
64	BKOF	Blk Off	0,1	Fix	0	0		
65	AGN2	Aging 2	0,1	Fix	0	0		
66	YSHU	Hue for YUV Models	0-63	Fix	31	31		
AP BH3868 (Group G,P - see table on page 28)								
67	BBLP	BBE Low Pass	0-15	Fix	5	5		
68	BBHP	BBE High Pass	0-15	Fix	3	3		
69	SVOL	Sub Volume	0-15	Fix	15	15		
70	SBAL	Sub Balance	0-15	Fix	7	7		
71	SBAS	Sub Bass	0-15	Fix	8	8		
72	STRE	Sub Treble	0-15	Fix	8	8		
AP BH3868 (Group I,J,M,R,V - see table on page 28)								
67	BBLP	BBE Low Pass	0-15	Fix	5	5		
68	BBHP	BBE High Pass	0-15	Fix	3	3		
69	SVOL	Sub Volume	0-15	Fix	7	7		
70	SBAL	Sub Balance	0-15	Fix	7	7		
71	SBAS	Sub Bass	0-15	Fix	8	8		
72	STRE	Sub Treble	0-15	Fix	8	8		
AP BH3868 (Group H,L,N,O,U,W,X - see table on page 28)								
67	BBLP	BBE Low Pass	0-15	Fix	5	5		
68	BBHP	BBE High Pass	0-15	Fix	3	3		
69	SVOL	Sub Volume	0-15	Fix	7	7		
70	SBAL	Sub Balance	0-15	Fix	7	7		
71	SBAS	Sub Bass	0-15	Fix	5	5		
72	STRE	Sub Treble	0-15	Fix	5	5		
AP TDA7467								
73	SPCA	SRS/Space Attenuation	0-63	Fix	0	0		
74	CENA	SRS/Center Attenuation	0-63	Fix	0	0		
75	INPA	Input Attenuation	0-127	Fix	3	3		
3D UPD64081								
76	HHDS	HH Off	0-3	Fix	1	1		
77	COUT	Gain 1/BPF On	0-3	Fix	3	3		
78	YAPS	V Comp/Y Eaking On	0-3	Fix	3	3		
79	NSDS	Adaptive	0-3	Fix	0	0		
80	MSS	Adaptive	0-3	Fix	0	0		
81	DYC	Hi Impedence	0-3	Fix	2	2		
82	EXAD	Ext Ad Selected	0,1	Fix	1	1		
83	PECS	Standard	0-3	Fix	0	0		
84	EXCS	Use CSI Just In Case	0-3	Fix	1	1		
85	CPP	VTB = 1.25VPP	0-3	Fix	0	0		
86	HDP	H Phase +/- 0 μ sec	0-7	Fix	3	3		
87	CDL	Y/C Delay +/- 0 μ sec	0-7	Fix	4	4		
88	DYCO	Y Moving Coring	0-15	Fix	2	2		
89	DYGA	Y Moving Gain	0-15	Fix	10	10		
90	DCCO	C Moving Coring	0-15	Fix	2	2		
91	DCGA	C Moving Gain	0-15	Fix	9	9		
92	YNRK	Effect Small	0,1	Fix	1	1		
93	YNRI	Effect Small	0,1	Fix	0	0		
94	YNRL	Noise Limit	0-3	Fix	1	1		
95	CNRK	Effect Small	0,1	Fix	1	1		
96	CNRI	Effect Small	0,1	Fix	0	0		
97	CNRL	CNR Limit	0-3	Fix	1	1		
98	ID10	ID 1 Through	0,1	Fix	0	0		
99	ID1W	4:03	0,1	Fix	0	0		
100	ID1N	Normal	0,1	Fix	0	0		
101	CLK	Low Fix	0,1	Fix	1	1		
102	ST1S	Monitor Out	0-3	Fix	0	0		
103	ST0S	Monitor Out	0-3	Fix	1	1		
104	WSC	Coring	0-3	Fix	1	1		
105	VTRH	H Non Standard DET	0-3	Fix	1	1		
106	VTRR	H Non Standard DET	0-3	Fix	1	1		
107	LDSR	Frame	0-3	Fix	2	2		
108	PWRE	PWRE	0,1	Fix	0	0		
109	PDRE	PDRE	0-7	Fix	4	4		
110	PBRE	PBRE	0-15	Fix	8	8		
111	VAPG	V Apacon Gain	0-7	Fix	3	3		
112	VAPI	V Apacon	0-31	Fix	10	10		
113	TEST	Test	0,1	Fix	0	0		
114	YPFT	Y Peaking	0-3	Fix	3	3		

Service Data (cont.)

No.	Register Name	Description	Data Range	Adj/Fix	Initial Data	Average Data**	Comments
						All Models	
3D UPD64081 <i>continued</i>							
115	YPFG	Y Peaking Gain	0-15	Fix	10	10	
116	V1PS	Line Comb Dot H	0-3	Fix	2	2	
117	VEGS	Line Comb Dot V	0-3	Fix	2	2	
118	CC3N	C Width	0,1	Fix	0	0	
119	C0HS	C Delay On	0,1	Fix	0	0	
120	CLPH	Y-Ad Clamp Test	0,1	Fix	0	0	
121	SEL2	DC Sensitivity Small	0,1	Fix	0	0	
122	SEL1	DY Sensitivity Small	0,1	Fix	0	0	
123	YHCO	Coring Small	0-3	Fix	1	1	
124	YPCO	Coring On	0,1	Fix	0	0	
125	ED2O	Standard	0,1	Fix	1	1	
126	OVST	Standard	0,1	Fix	0	0	
127	CSHD	Standard	0,1	Fix	0	0	
128	KCTT	Standard	0-3	Fix	0	0	
129	SHT1	Standard	0,1	Fix	0	0	
130	SHT0	Standard	0,1	Fix	0	0	
131	VCT	Standard	0,1	Fix	0	0	
132	OTT	Standard	0,1	Fix	0	0	
133	CGAT	Standard	0,1	Fix	0	0	
134	CGGT	Standard	0,1	Fix	0	0	
135	CGFT	Standard	0,1	Fix	0	0	
136	CGT	Standard	0,1	Fix	0	0	
137	HPLL	H PLL Fast	0,1	Fix	1	1	
138	BPLL	Burst PLL Fast	0,1	Fix	0	0	
139	FSCF	Burst Gain Large	0,1	Fix	0	0	
140	PLLF	PLL Loop Gain Large	0,1	Fix	1	1	
141	KILR	Killer Level	0-15	Fix	3	3	
142	HSSL	H Slice Level	0-15	Fix	12	12	
143	VSSL	V Slice Level	0-15	Fix	8	8	
144	BGPS	Start Burst Gate	0-15	Fix	4	4	
145	BGPW	Width of Burst Gate	0-15	Fix	10	10	
146	ADCL	ADC Clock	0-3	Fix	3	3	
147	ADPD	ADC Power Down On	0,1	Fix	1	1	
148	ADLT	Standard	0,1	Fix	0	0	
149	NRZO	Check On	0,1	Fix	0	0	
150	FSCO	Level Check On	0,1	Fix	0	0	
151	VTVH	Normal	0-3	Fix	0	0	
152	TST2	Standard	0,1	Fix	0	0	
153	HMEM	Use	0,1	Fix	1	1	
154	HINV	Polarity of Reset	0,1	Fix	1	1	
155	HTMG	Field Memory Address	0,1	Fix	0	0	
156	HCP	HH Carrier Phase	0-15	Fix	7	7	
157	TST3	Test	0,1	Fix	0	0	
158	HHMG	HH Moving Gain	0,1	Fix	1	1	
159	HHFG	HH	0-3	Fix	0	0	
160	HHTG	Max HH	0-15	Fix	5	5	
PI TA1226N							
161	SHPR	Picture Improvement Sharpness	0-127	Fix	59	59	
162	BLAD	Picture Improvement Black Area Detect	0-3	Fix	0	0	
163	SRTS	Picture Improvement SRT Start Pos	0-3	Fix	3	3	
164	YNR	Picture Improvement YNR	0,1	Fix	1	1	
165	GIRE	Picture Improvement Gamma Start Point	0-3	Fix	3	3	
166	DAC1	Picture Improvement DAC1	0,1	Fix	0	0	
167	DAC2	Picture Improvement DAC2	0,1	Fix	0	0	
168	GCUR	Picture Improvement Gamma Curve	0,1	Fix	0	0	
169	BLKC	Picture Improvement Black Compensation	0,1	Fix	1	1	
170	TEST	Picture Improvement Test	0-3	Fix	3	3	
171	RS	Picture Improvement RS	0-7	Fix	0	0	
172	RTC	Picture Improvement RTC	0-7	Fix	4	4	

Service Data (cont.)

No.	Register Name	Description	Data Range	Adj/Fix	Initial Data	Average Data**	Comments
						All Models	
DC CXA2060							
173	DCSF	Dynamic Convergence DC Shift	0-63	Fix	40	40	
174	UYBW	Dynamic Convergence Upper YBOW	0-63	Fix	31	31	
175	LYBW	Dynamic Convergence Lower YBOW	0-63	Fix	31	31	
176	HAMP	Dynamic Convergence H. Amp	0-63	Fix	15	15	
177	UCBW	Dynamic Convergence U. CBOW	0-63	Fix	21	21	
178	LCBW	Dynamic Convergence L. CBOW	0-63	Fix	14	14	
179	UMBH	Dynamic Convergence U. MBH	0-63	Fix	15	15	
180	LMBH	Dynamic Convergence L. MBH	0-63	Fix	15	15	
181	PWM	Dynamic Convergence PWM	0-63	Fix	63	63	
182	HTLT	Dynamic Convergence H. Tilt	0-63	Fix	1	1	
183	UTLT	Dynamic Convergence U. Tilt	0-63	Fix	1	1	
184	LTLT	Dynamic Convergence L. Tilt	0-63	Fix	1	1	
185	HDTY	Dynamic Convergence H. Duty	0-3	Fix	3	3	
186	TOFF	Dynamic Convergence Tilt Off	0,1	Fix	1	1	
187	DAC0	Dynamic Convergence DAC0	0-255	Fix	192	192	
188	DAC1	Dynamic Convergence DAC1	0-255	Fix	7	7	

SP SDA9288							
189	PYSD	P in P (Siemens) YS Delay	0-15	Fix	2	2	
190	PIPH	P in P (Siemens) H-Position	0-127	Fix	78	78	
191	PIPV	P in P (Siemens) V-Position	0-63	Fix	18	18	
192	PYDL	P in P (Siemens) Y-Delay	0-7	Fix	0	0	
193	PIFX	P in P Inset Fixed	0-3	Fix	2	2	
194	PPFX	P in P Parent Fixed	0-3	Fix	2	2	
195	PCLI	P in P CLISW	0,1	Fix	1	1	
196	PAMS	P in P AMSEC	0,1	Fix	0	0	
197	PHDL	P in P (Siemens) H-Pulse Delay (Inset)	0-15	Fix	15	15	
198	PMVD	P in P (Siemens) V-Pulse Delay (Main)	0-31	Fix	11	11	
199	PIVD	P in P (Siemens) V-Pulse Delay (Inset)	0-31	Fix	18	18	
200	PCON	P in P (Siemens) Contrast Level (Inset)	0-15	Fix	7	1	
201	FRMY	P in P (Siemens) Frame Y	0-15	Fix	10	10	
202	CHRI	P in P (Siemens) Chroma Input Polarity	0,1	Fix	0	0	
203	CHRO	P in P (Siemens) Chroma Output Polarity	0,1	Fix	0	0	
204	MAT0	P in P (Siemens) MAT0	0,1	Fix	1	1	
205	MAT1	P in P (Siemens) MAT1	0,1	Fix	1	1	
206	MAT2	P in P (Siemens) MAT2	0,1	Fix	0	0	
207	IPER	P in P (Siemens) Pedastel R-Y	0-15	Fix	0	0	
208	IPEB	P in P (Siemens) Pedastel B-Y	0-15	Fix	0	0	
209	PCPS	P in P (Siemens) CLP & HSIDEL	0,1	Fix	0	0	
210	PCPF	P in P (Siemens) CLP Cycles	0,1	Fix	0	0	
211	PSEL	P in P (Siemens) SELDOWN	0,1	Fix	1	1	
212	PPLL	P in P (Siemens) PLL Filter	0-3	Fix	0	0	
213	PVNR	P in P (Siemens) VSP Pulse Noise Red.	0,1	Fix	0	0	

Note: PIP Setting - IC SDA9288 *continued*

SERVICE MODE ITEM	Model Groups
	32V / 34V / 36V / 38V
IC (SDA9288)	
PHDL (HSI DELAY)	15
PMVD (VSP DELAY)	11
PIVD (VSI DELAY)	18
PCON (CONTRAST)	1

IC CXA2019							
214	IDPX		0,1	Fix	0	0	
215	ICOL	Color	0-63	Fix	38	38	
216	ISHP	Sharpness	0-15	Fix	10	10	
217	ISCO	Sub Chroma Decoder Sub Cont	0-15	Fix	7	7	
218	ISCL	Sub Chroma Decoder Sub Color	0-15	Fix	12	8	
219	ISHU	Sub Chroma Decoder Sub Hue	0-15	Fix	7	7	
220	ITOT	Sub Chroma Decoder Tot On	0,1	Fix	0	0	
221	ITRP	Sub Chroma Decoder Trap On	0,1	Fix	1	1	
222	IAFC	AFC	0-3	Fix	1	1	
223	ITRA	Sub Chroma Decoder CTRAPADJ	0-15	Fix	7	7	
224	ICD2	Sub Chroma Decoder CD Mode2	0,1	Fix	1	1	
225	ISF0	SHP-F0	0,1	Fix	1	1	
226	IYDR	Sub Chroma Decoder Y Drive	0-31	Fix	24	24	
227	IVPE	Sub Chroma Decoder V Ped	0-15	Fix	0	0	
228	IUPE	Sub Chroma Decoder U Ped	0-15	Fix	0	0	
229	IRVP	Sub Chroma Decoder RV Ped	0-15	Fix	7	7	
230	IRUP	Sub Chroma Decoder RU Ped	0-15	Fix	4	7	

Service Data (cont.)

No.	Register Name	Description	Data Range	Adj/Fix	Initial Data	Average Data**	Comments
						All Models	
IC CXA2019 <i>continued</i>							
231	IDCT	Sub Chroma Decoder DC Tran	0-7	Fix	6	6	
232	IRYD	Sub Chroma Decoder RY Drive	0-31	Fix	19	19	
233	IPRE	Sub Chroma Decoder Pre Over	0-3	Fix	1	1	
234	IRUD	Sub Chroma Decoder RU Drive	0-31	Fix	8	8	
235	IRVD	Sub Chroma Decoder RV Drive	0-31	Fix	8	8	
236	IDLY	Sub Chroma Decoder Delay	0-3	Fix	0	0	
237	ISCR	Sub Chroma Decoder SCP BGR	0-3	Fix	1	1	
238	ISCF	Sub Chroma Decoder SCP BGF	0-3	Fix	1	1	
Note: PIP Setting - IC CXA2019 <i>continued</i>							
		SERVICE MODE ITEM	Model Groups				
		IC (CXA2019AQ)	32V / 34V / 36V / 38V				
		ICSL (SUB-COLOR)	8				
		IVPE (V PEDESTAL)	0				
		IUPE (U PEDESTAL)	0				
		IRVP (V PEDESTAL2)	7				
		IRUP (U PEDESTAL2)	7				
		IDCT (DC TRAN)	6				
DA CXA1315							
239	RTCO	D/A Converter N-S Correction	0-63	Fix	32	32	
240	2COL	Color	0-255	Fix	120	120	
241	4COL	Color	0-255	Fix	120	120	
242	2SHU	Sub Hue	0-31	Fix	15	15	
243	4SHU	Sub Hue	0-31	Fix	15	15	
D1 CXD2085							
244	XJGL	XJGLK	0,1	Fix	0	0	
245	LNJ1	LNJ1	0,1	Fix	0	0	
CC CXP85856A							
246	CRIL	CCD CRI Pulse Compare Data Low	0-15	Fix	2	2	
247	CFLD	CCD Caption Fixed-Field Count	0-15	Fix	5	5	
248	CCDI	CCD No CCD Interrupt	0-7	Fix	3	3	
249	CRIP	CCD CRI & Parity Error	0-7	Fix	4	4	
250	CRIT	CCD CRI Time Constant	0-3	Fix	0	0	
251	CSB1	CCD Sync Slice Bias 1	0-3	Fix	3	3	
252	CSB2	CCD Sync Slice Bias 2	0-7	Fix	4	4	
253	CREP	CCD CRI Signal End Position	0-256	Fix	142	142	
254	CSDS	CCD Data Start Delay	0-31	Fix	8	8	
255	CCDS	CCD Caption Data Threshold	0-31	Fix	9	9	
256	CHMK	CCD P8-HMASK	0-63	Fix	42	42	
257	CHSY	CCD P8-HSYC	0-255	Fix	136	136	
OP CXP85856A							
258	DISP	OSD Position	0-63	Adj	1	1	
ID MAP							
259	ID 0	NVM ID 0	0-255	Fix by model	89	89	See ID map
260	ID 1	NVM ID 1	0-255	Fix by model	55	55	See ID map
261	ID 2	NVM ID 2	0-255	Fix by model	175	175	See ID map
262	ID 3	NVM ID 3	0-255	Fix by model	96	96	See ID map
263	ID 4	NVM ID 4	0-255	Fix by model	203	203	See ID map
264	ID 5	NVM ID 5	0-255	Fix by model	181	181	See ID map
265	ID 6	NVM ID 6	0-255	Fix by model	6	6	See ID map
266	ID 7	NVM ID 7	0-255	Fix by model	9	9	See ID map

(5) Feature ID Map

	ID 0	ID 1	ID 2	ID 3	ID 4	ID 5	ID 6	ID 7
KV-32FS10	89	63	47	96	203	177	0	0
KV-32FS10CND	89	63	47	112	203	177	0	0
KV-34FV10	25	63	175	64	251	177	0	0
KV-32FV15	89	63	175	96	203	181	6	0
KV-32FV15CND	89	63	175	112	203	181	6	0
KV-34FV15	25	63	175	64	251	181	6	0
KV-34FV15C	25	63	175	64	251	181	6	0
KV-34FV15T	9	63	175	64	219	181	6	0
KV-34FV15K	137	63	175	64	219	181	6	0
KV-32XBR250	89	63	175	96	203	181	6	9
KV-32XBR250CND	89	63	175	112	203	181	6	9
KV-34FX250C	25	63	175	64	251	181	6	9
KV-36FS10	89	63	47	96	203	177	0	0
KV-36FS10CND	89	63	47	112	203	177	0	0
KV-36FV15	89	63	175	96	203	181	6	0
KV-36FV15CND	89	63	175	112	203	181	6	0
KV-38FV15K	137	63	175	64	219	181	6	0
KV-36XBR250	89	63	175	96	203	181	6	9
KV-36XBR250CND	89	63	175	112	203	181	6	9
KV-38FX250	25	63	175	64	251	181	6	9
KV-38FX250C	25	63	175	64	251	181	6	9
KV-38FX250T	9	63	175	64	219	181	6	9

SERVICE IDO 25

Note: Items 1-266 show adjustment order

GROUP	FEATURES	NAME
G	32inchx120Vac	KV-32FS10 (8978(U)/8979(CND))
H	32inchxAUTO	KV-34FV10 (8980(E))
I	32inchx120VacxPIP	KV-32FV15 (8973(U)/8974(CND))
J	32inchx120VacxPIPxNO V Chip	KV-34FV15T (10189(WB))
K	32inchx120VacxPIPx3D	KV-32XBR250 (8969(U)/8970(CND))
L	32inchxAUTOxPIP	KV-34FV15 (8975(E), KV-34FV15C (8977(E)))
M	32inchxAUTOxPIPxKOREA	KV-34FV15K (10188(K))
N	32inchxAUTOxPIPx3D	KV-34FX250C (8972(E))
P	36inchx120Vac	KV-36FS10 (8989(U)/8990(CND))
R	36inchx120VacxPIP	KV-36FV15 (8987(U)/8988(CND))
S	36inchx120VacxPIPx3D	KV-36XBR250 (8981(U)/8982(CND))
T	36inchx120VacxPIPx3DxNO V Chip	KV-38FX250T (10190(WB))
U	36inchxAUTOxPIPx3D	KV-38FX250 (8983(E), KV-38FX250C (8986(EW)))
V	36inchxAUTOxPIP	KV-38FV15K (10191(K))

SUB BRIGHT ADJUSTMENT (SBRT)

1. Set to Service adjustment Mode.
2. Input a gray scale pattern signal.
3. Set the PICTURE to minimum, and BRIGHT to normal.
4. Select SBRT with **[1]** and **[4]**.
5. Adjust SUB BRIGHT level with **[3]** and **[6]** so that the stripe second from the right is faintly visible.
6. Write into the memory by pressing **[MUTING]** then **[ENTER]**.

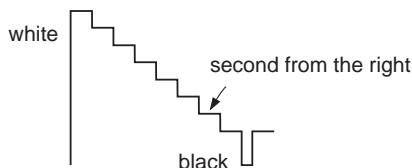

SUB CONTRAST ADJUSTMENT (RDRV)

1. Input a 75% color-bar signal.
2. Set to VIDEO mode = STANDARD, COLOR = minimum, PICTURE = 100%.
GON = 0 (OFF), BON = 0 (OFF).
3. Set to Service adjustment Mode and Connect an oscilloscope pin ① of CN351 on A Board.
4. Select RDRV with **[1]** and **[4]**.
5. Adjust with **[3]** and **[6]** for the $1.85 \pm 0.05V_{p-p}$ of level.
6. Write into the memory by **[MUTING]** then **[ENTER]**.

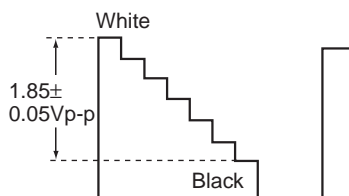

SUB HUE, SUB COLOR ADJUSTMENT (2SHU, 2COL, 4SHU, 4COL)

**NOTE: 4SHU and 4COL are for Video 4 input.
2SHU and 2COL are for all other inputs.**

1. Input a color bar signal.
2. Set to Service Adjustment Mode and set to VIDEO mode = STANDARD
PICTURE = 100%
COLOR = 50%
HUE = 50%.
3. Connect an oscilloscope to CN351 Pin ③ of A Board.
4. Select SHUE and SCOL with **[1]** and **[4]**.
5. Adjust with **[3]** and **[6]** for the $V1 = V4$ (2COL) and $V2 = V3$ (2SHU).
6. Write SHUE data 1 step down from even condition to NVM. 2COL is adjusted by 2SHU compensation.
7. Write into the memory by pressing **[MUTING]** then **[ENTER]**.

NOTE: Procedure for 4SHU and 4COL is same as above.

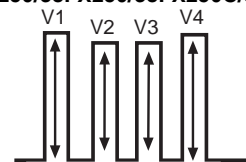

H. SIZE ADJUSTMENT (HSIZ)

1. Input a monoscope signal.
2. Set to Service Adjustment Mode.
3. Select HSIZ with **[1]** and **[4]**.
4. Adjust with **[3]** and **[6]** for the best Horizontal size.
5. Write into the memory by pressing **[MUTING]** then **[ENTER]**.

H. SIZE

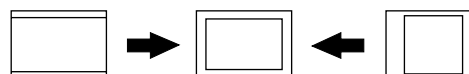

V. SIZE ADJUSTMENT (VSIZ)

1. Input a monoscope signal.
2. Set to Service Adjustment mode.
3. Select VSIZ with **[1]** and **[4]**.
4. Adjust with **[3]** and **[6]** for the best vertical size.
5. Write into the memory by pressing **[MUTING]** then **[ENTER]**.

V. SIZE

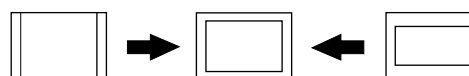

V. POSITION ADJUSTMENT (VPOS)

1. Input a monoscope signal.
2. Set to Service Adjustment Mode.
3. Select VPOS with **[1]** and **[4]**.
4. Adjust with **[3]** and **[6]** for the best vertical center.
5. Write into the memory by pressing **[MUTING]** then **[ENTER]**.

V. POSITION



H. POSITION ADJUSTMENT (HPOS)

HPOS data range is from 0~15.

1. Input a monoscope signal.
2. Set the Service adjustment Mode.
3. Select HPOS with **[1]** and **[4]**.
4. Adjust with **[3]** and **[6]** for the best horizontal center.
5. Write into the memory by pressing **[MUTING]** then **[ENTER]**.

H. POSITION

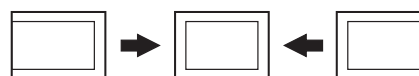

V LINEARITY (VLIN), V CORRECTION (VSCO), PIN AMP (PAMP) AND TRAPEZIUM (TRAP) ADJUSTMENTS

1. Input a cross-hatch signal.
2. Set to Service adjustment Mode.
3. Select VLIN, VSCO, PAMP, and TRAP with [1] and [4].
4. Adjust with [3] and [6] for the best picture.
5. Write the memory by Pressing [MUTING] then [ENTER].

V LINEARITY(VLIN)

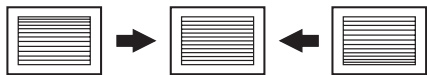

VS CORRECTION (VSCO)

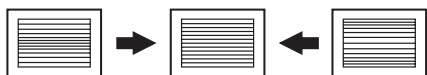

PIN AMP (PAMP)



TRAPEZIUM (TRAP)



V ANGLE (VANG), V BOW (VBOW), UPPER PIN (UCPN) AND LOW PIN (LCPN) ADJUSTMENTS

1. Input a cross hatch signal.
2. Set to Service Adjustment Mode.
3. Select VVANG, VBOW, UCPN, and LCPN with [1] and [4].
4. Adjust with [3] and [6] for the best picture.
5. Write the memory by Pressing [MUTING] then [ENTER].

Please use VANG data from 3~12. Adjust from 3 to12 only.

V ANGLE (VANG)

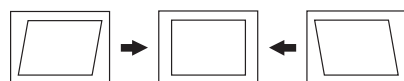

V BOW (VBOW)



UPPER PIN (UCPN)



LOW PIN (LCPN)



OSD POSITION ADJUSTMENT (DISP)

1. Input a color bar signal.
2. Set to Service adjustment Mode.
3. Select DISP with [1] and [4].
4. Adjust with [3] and [6] for the bar center.
5. Write into the memory by pressing [MUTING] then [ENTER].

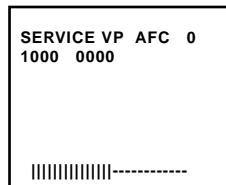

ROTATION COIL ADJUSTMENT

1. Input a monoscope signal.
2. Push Menu button on the Remote (RM-Y171).
3. Select "Set Up" Mode.
4. Select "Tilt Correction". Confirm that number (0) color changes to red.
5. Push ↑ (+) on the Remote (RM-Y171). Confirm that number increases up to +5 and picture rotates clockwise.
6. Push ↓ (-) on the Remote (RM-Y171). Confirm that number decreases up to -5 and picture rotates counterclockwise.
7. Push ↑ (+) on the Remote (RM-Y171). Return to 0.

SET-UP

- Channel Set-up
- Favorite Channel
- Video Label
- Language: English
- Tilt Correction : 0
- Menu

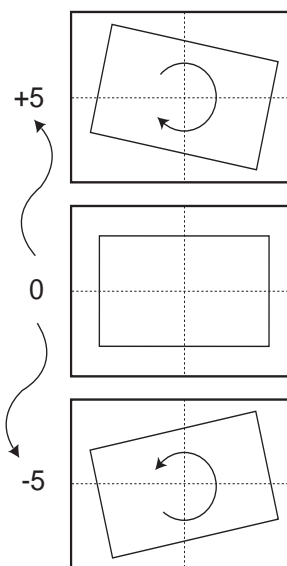

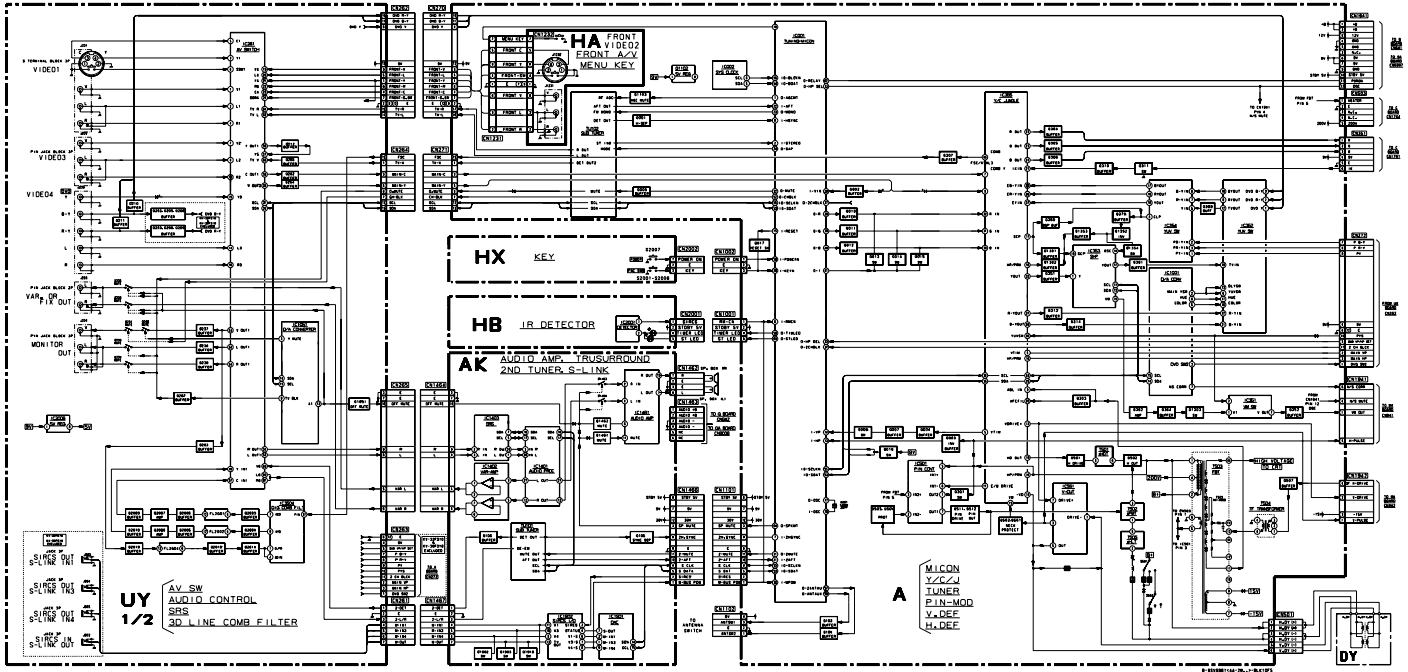

AK BOARD SCHEMATIC DIAGRAM

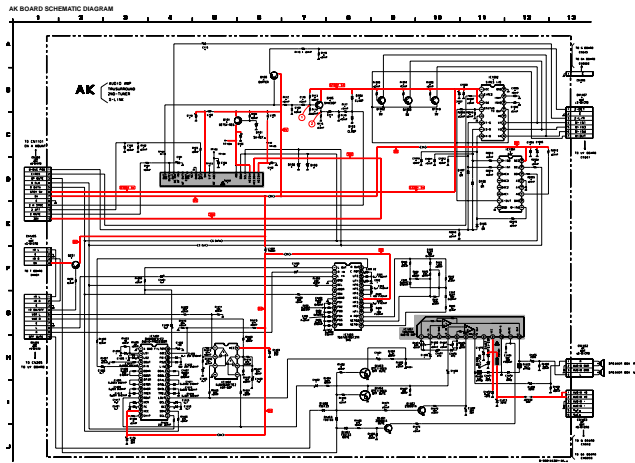

AK BOARD WAVEFORMS



AK BOARD PARTS LIST

REF. ID	LOCATION	DESCRIPTION	QTY	REMARKS
1001	101	RESISTOR	1	
1002	102	RESISTOR	1	
1003	103	RESISTOR	1	
1004	104	RESISTOR	1	
1005	105	RESISTOR	1	
1006	106	RESISTOR	1	
1007	107	RESISTOR	1	
1008	108	RESISTOR	1	
1009	109	RESISTOR	1	
1010	110	RESISTOR	1	
1011	111	RESISTOR	1	
1012	112	RESISTOR	1	
1013	113	RESISTOR	1	
1014	114	RESISTOR	1	
1015	115	RESISTOR	1	
1016	116	RESISTOR	1	
1017	117	RESISTOR	1	
1018	118	RESISTOR	1	
1019	119	RESISTOR	1	
1020	120	RESISTOR	1	
1021	121	RESISTOR	1	
1022	122	RESISTOR	1	
1023	123	RESISTOR	1	
1024	124	RESISTOR	1	
1025	125	RESISTOR	1	
1026	126	RESISTOR	1	
1027	127	RESISTOR	1	
1028	128	RESISTOR	1	
1029	129	RESISTOR	1	
1030	130	RESISTOR	1	
1031	131	RESISTOR	1	
1032	132	RESISTOR	1	
1033	133	RESISTOR	1	
1034	134	RESISTOR	1	
1035	135	RESISTOR	1	
1036	136	RESISTOR	1	
1037	137	RESISTOR	1	
1038	138	RESISTOR	1	
1039	139	RESISTOR	1	
1040	140	RESISTOR	1	
1041	141	RESISTOR	1	
1042	142	RESISTOR	1	
1043	143	RESISTOR	1	
1044	144	RESISTOR	1	
1045	145	RESISTOR	1	
1046	146	RESISTOR	1	
1047	147	RESISTOR	1	
1048	148	RESISTOR	1	
1049	149	RESISTOR	1	
1050	150	RESISTOR	1	
1051	151	RESISTOR	1	
1052	152	RESISTOR	1	
1053	153	RESISTOR	1	
1054	154	RESISTOR	1	
1055	155	RESISTOR	1	
1056	156	RESISTOR	1	
1057	157	RESISTOR	1	
1058	158	RESISTOR	1	
1059	159	RESISTOR	1	
1060	160	RESISTOR	1	
1061	161	RESISTOR	1	
1062	162	RESISTOR	1	
1063	163	RESISTOR	1	
1064	164	RESISTOR	1	
1065	165	RESISTOR	1	
1066	166	RESISTOR	1	
1067	167	RESISTOR	1	
1068	168	RESISTOR	1	
1069	169	RESISTOR	1	
1070	170	RESISTOR	1	
1071	171	RESISTOR	1	
1072	172	RESISTOR	1	
1073	173	RESISTOR	1	
1074	174	RESISTOR	1	
1075	175	RESISTOR	1	
1076	176	RESISTOR	1	
1077	177	RESISTOR	1	
1078	178	RESISTOR	1	
1079	179	RESISTOR	1	
1080	180	RESISTOR	1	
1081	181	RESISTOR	1	
1082	182	RESISTOR	1	
1083	183	RESISTOR	1	
1084	184	RESISTOR	1	
1085	185	RESISTOR	1	
1086	186	RESISTOR	1	
1087	187	RESISTOR	1	
1088	188	RESISTOR	1	
1089	189	RESISTOR	1	
1090	190	RESISTOR	1	
1091	191	RESISTOR	1	
1092	192	RESISTOR	1	
1093	193	RESISTOR	1	
1094	194	RESISTOR	1	
1095	195	RESISTOR	1	
1096	196	RESISTOR	1	
1097	197	RESISTOR	1	
1098	198	RESISTOR	1	
1099	199	RESISTOR	1	
1100	200	RESISTOR	1	
1101	201	RESISTOR	1	
1102	202	RESISTOR	1	
1103	203	RESISTOR	1	
1104	204	RESISTOR	1	
1105	205	RESISTOR	1	
1106	206	RESISTOR	1	
1107	207	RESISTOR	1	
1108	208	RESISTOR	1	
1109	209	RESISTOR	1	
1110	210	RESISTOR	1	
1111	211	RESISTOR	1	
1112	212	RESISTOR	1	
1113	213	RESISTOR	1	
1114	214	RESISTOR	1	
1115	215	RESISTOR	1	
1116	216	RESISTOR	1	
1117	217	RESISTOR	1	
1118	218	RESISTOR	1	
1119	219	RESISTOR	1	
1120	220	RESISTOR	1	
1121	221	RESISTOR	1	
1122	222	RESISTOR	1	
1123	223	RESISTOR	1	
1124	224	RESISTOR	1	
1125	225	RESISTOR	1	
1126	226	RESISTOR	1	
1127	227	RESISTOR	1	
1128	228	RESISTOR	1	
1129	229	RESISTOR	1	
1130	230	RESISTOR	1	
1131	231	RESISTOR	1	
1132	232	RESISTOR	1	
1133	233	RESISTOR	1	
1134	234	RESISTOR	1	
1135	235	RESISTOR	1	
1136	236	RESISTOR	1	
1137	237	RESISTOR	1	
1138	238	RESISTOR	1	
1139	239	RESISTOR	1	
1140	240	RESISTOR	1	
1141	241	RESISTOR	1	
1142	242	RESISTOR	1	
1143	243	RESISTOR	1	
1144	244	RESISTOR	1	
1145	245	RESISTOR	1	
1146	246	RESISTOR	1	
1147	247	RESISTOR	1	
1148	248	RESISTOR	1	
1149	249	RESISTOR	1	
1150	250	RESISTOR	1	
1151	251	RESISTOR	1	
1152	252	RESISTOR	1	
1153	253	RESISTOR	1	
1154	254	RESISTOR	1	
1155	255	RESISTOR	1	
1156	256	RESISTOR	1	
1157	257	RESISTOR	1	
1158	258	RESISTOR	1	
1159	259	RESISTOR	1	
1160	260	RESISTOR	1	
1161	261	RESISTOR	1	
1162	262	RESISTOR	1	
1163	263	RESISTOR	1	
1164	264	RESISTOR	1	
1165	265	RESISTOR	1	
1166	266	RESISTOR	1	
1167	267	RESISTOR	1	
1168	268	RESISTOR	1	
1169	269	RESISTOR	1	
1170	270	RESISTOR	1	
1171	271	RESISTOR	1	
1172	272	RESISTOR	1	
1173	273	RESISTOR	1	
1174	274	RESISTOR	1	
1175	275	RESISTOR	1	
1176	276	RESISTOR	1	
1177	277	RESISTOR	1	
1178	278	RESISTOR	1	
1179	279	RESISTOR	1	
1180	280	RESISTOR	1	
1181	281	RESISTOR	1	
1182	282	RESISTOR	1	
1183	283	RESISTOR	1	
1184	284	RESISTOR	1	
1185	285	RESISTOR	1	
1186	286	RESISTOR	1	
1187	287	RESISTOR	1	
1188	288	RESISTOR	1	
1189	289	RESISTOR	1	
1190	290	RESISTOR	1	
1191	291	RESISTOR	1	
1192	292	RESISTOR	1	
1193	293	RESISTOR	1	
1194	294	RESISTOR	1	
1195	295	RESISTOR	1	
1196	296	RESISTOR	1	
1197	297	RESISTOR	1	
1198	298	RESISTOR	1	
1199	299	RESISTOR	1	
1200	300	RESISTOR	1	
1201	301	RESISTOR	1	
1202	302	RESISTOR	1	
1203	303	RESISTOR	1	
1204	304	RESISTOR	1	
1205	305	RESISTOR	1	
1206	306	RESISTOR	1	
1207	307	RESISTOR	1	
1208	308	RESISTOR	1	
1209	309	RESISTOR	1	
1210	310	RESISTOR	1	
1211	311	RESISTOR	1	
1212	312	RESISTOR	1	
1213	313	RESISTOR	1	
1214	314	RESISTOR	1	
1215	315	RESISTOR	1	
1216	316	RESISTOR	1	
1217	317	RESISTOR	1	
1218	318	RESISTOR	1	
1219	319	RESISTOR	1	
1220	320	RESISTOR	1	
1221	321	RESISTOR	1	
1222	322	RESISTOR	1	
1223	323	RESISTOR	1	
1224	324	RESISTOR	1	
1225	325	RESISTOR	1	
1226	326	RESISTOR	1	
1227	327	RESISTOR	1	
1228	328	RESISTOR	1	
1229	329	RESISTOR	1	
1230	330	RESISTOR	1	
1231	331	RESISTOR	1	
1232	332	RESISTOR	1	
1233	333	RESISTOR	1	
1234	334	RESISTOR	1	
1235	335	RESISTOR	1	
1236	336	RESISTOR	1	
1237	337	RESISTOR	1	
1238	338	RESISTOR	1	
1239	339	RESISTOR	1	
1240	340	RESISTOR	1	
1241	341	RESISTOR	1	
1242	342	RESISTOR	1	
1243	343	RESISTOR	1	
1244	344	RESISTOR	1	
1245	345	RESISTOR	1	
1246	346	RESISTOR	1	
1247	347	RESISTOR	1	
1248	348	RESISTOR	1	
1249	349	RESISTOR	1	
1250	350	RESISTOR	1	
1251	351	RESISTOR	1	
1252	352	RESISTOR	1	
1253	353	RESISTOR	1	
1254	354	RESISTOR	1	
1255	355	RESISTOR	1	
1256	356	RESISTOR	1	
1257	357	RESISTOR	1	
1258	358	RESISTOR	1	
1259	359	RESISTOR	1	
1260	360	RESISTOR	1	
1261	361	RESISTOR	1	
1262	362	RESISTOR	1	
1263	363	RESISTOR	1	
1264	364	RESISTOR	1	
1265	365	RESISTOR	1	
1266	366	RESISTOR	1	
1267	367	RESISTOR	1	
1268	368	RESISTOR	1	
1269	369	RESISTOR	1	
1270	370	RESISTOR	1	
1271	371	RESISTOR	1	
1272	372	RESISTOR	1	
1273	373	RESISTOR	1	
1274	374	RESISTOR	1	
1275	375	RESISTOR	1	
1276	376	RESISTOR	1	
1277	377	RESISTOR	1	
1278	378	RESISTOR	1	
1279	379	RESISTOR	1	
1280	380	RESISTOR	1	
1281	381	RESISTOR	1	
1282	382	RESISTOR	1	
1283	383	RESISTOR	1	
1284	384	RESISTOR	1	
1285	385	RESISTOR	1	
1286	386	RESISTOR	1	
1287	387	RESISTOR	1	
1288	388	RESISTOR	1	
1289	389	RESISTOR	1	
1290	390	RESISTOR	1	
1291	391	RESISTOR	1	
1292	392	RESISTOR	1	
1293	393	RESISTOR	1	
1294	394	RESISTOR	1	
1295	395	RESISTOR	1	
1296	396	RESISTOR	1	
1297	397	RESISTOR		

KY 3PFI 100PFI 105PFI 108PFI 109PFI 110PFI 111PFI 112PFI 113PFI 114PFI 115PFI 116PFI 117PFI 118PFI 119PFI 120PFI 121PFI 122PFI 123PFI 124PFI 125PFI 126PFI 127PFI 128PFI 129PFI 130PFI 131PFI 132PFI 133PFI 134PFI 135PFI 136PFI 137PFI 138PFI 139PFI 140PFI 141PFI 142PFI 143PFI 144PFI 145PFI 146PFI 147PFI 148PFI 149PFI 150PFI 151PFI 152PFI 153PFI 154PFI 155PFI 156PFI 157PFI 158PFI 159PFI 160PFI 161PFI 162PFI 163PFI 164PFI 165PFI 166PFI 167PFI 168PFI 169PFI 170PFI 171PFI 172PFI 173PFI 174PFI 175PFI 176PFI 177PFI 178PFI 179PFI 180PFI 181PFI 182PFI 183PFI 184PFI 185PFI 186PFI 187PFI 188PFI 189PFI 190PFI 191PFI 192PFI 193PFI 194PFI 195PFI 196PFI 197PFI 198PFI 199PFI 200PFI 201PFI 202PFI 203PFI 204PFI 205PFI 206PFI 207PFI 208PFI 209PFI 210PFI 211PFI 212PFI 213PFI 214PFI 215PFI 216PFI 217PFI 218PFI 219PFI 220PFI 221PFI 222PFI 223PFI 224PFI 225PFI 226PFI 227PFI 228PFI 229PFI 230PFI 231PFI 232PFI 233PFI 234PFI 235PFI 236PFI 237PFI 238PFI 239PFI 240PFI 241PFI 242PFI 243PFI 244PFI 245PFI 246PFI 247PFI 248PFI 249PFI 250PFI 251PFI 252PFI 253PFI 254PFI 255PFI 256PFI 257PFI 258PFI 259PFI 260PFI 261PFI 262PFI 263PFI 264PFI 265PFI 266PFI 267PFI 268PFI 269PFI 270PFI 271PFI 272PFI 273PFI 274PFI 275PFI 276PFI 277PFI 278PFI 279PFI 280PFI 281PFI 282PFI 283PFI 284PFI 285PFI 286PFI 287PFI 288PFI 289PFI 290PFI 291PFI 292PFI 293PFI 294PFI 295PFI 296PFI 297PFI 298PFI 299PFI 300PFI 301PFI 302PFI 303PFI 304PFI 305PFI 306PFI 307PFI 308PFI 309PFI 310PFI 311PFI 312PFI 313PFI 314PFI 315PFI 316PFI 317PFI 318PFI 319PFI 320PFI 321PFI 322PFI 323PFI 324PFI 325PFI 326PFI 327PFI 328PFI 329PFI 330PFI 331PFI 332PFI 333PFI 334PFI 335PFI 336PFI 337PFI 338PFI 339PFI 340PFI 341PFI 342PFI 343PFI 344PFI 345PFI 346PFI 347PFI 348PFI 349PFI 350PFI 351PFI 352PFI 353PFI 354PFI 355PFI 356PFI 357PFI 358PFI 359PFI 360PFI 361PFI 362PFI 363PFI 364PFI 365PFI 366PFI 367PFI 368PFI 369PFI 370PFI 371PFI 372PFI 373PFI 374PFI 375PFI 376PFI 377PFI 378PFI 379PFI 380PFI 381PFI 382PFI 383PFI 384PFI 385PFI 386PFI 387PFI 388PFI 389PFI 390PFI 391PFI 392PFI 393PFI 394PFI 395PFI 396PFI 397PFI 398PFI 399PFI 400PFI 401PFI 402PFI 403PFI 404PFI 405PFI 406PFI 407PFI 408PFI 409PFI 410PFI 411PFI 412PFI 413PFI 414PFI 415PFI 416PFI 417PFI 418PFI 419PFI 420PFI 421PFI 422PFI 423PFI 424PFI 425PFI 426PFI 427PFI 428PFI 429PFI 430PFI 431PFI 432PFI 433PFI 434PFI 435PFI 436PFI 437PFI 438PFI 439PFI 440PFI 441PFI 442PFI 443PFI 444PFI 445PFI 446PFI 447PFI 448PFI 449PFI 450PFI 451PFI 452PFI 453PFI 454PFI 455PFI 456PFI 457PFI 458PFI 459PFI 460PFI 461PFI 462PFI 463PFI 464PFI 465PFI 466PFI 467PFI 468PFI 469PFI 470PFI 471PFI 472PFI 473PFI 474PFI 475PFI 476PFI 477PFI 478PFI 479PFI 480PFI 481PFI 482PFI 483PFI 484PFI 485PFI 486PFI 487PFI 488PFI 489PFI 490PFI 491PFI 492PFI 493PFI 494PFI 495PFI 496PFI 497PFI 498PFI 499PFI 500PFI 501PFI 502PFI 503PFI 504PFI 505PFI 506PFI 507PFI 508PFI 509PFI 510PFI 511PFI 512PFI 513PFI 514PFI 515PFI 516PFI 517PFI 518PFI 519PFI 520PFI 521PFI 522PFI 523PFI 524PFI 525PFI 526PFI 527PFI 528PFI 529PFI 530PFI 531PFI 532PFI 533PFI 534PFI 535PFI 536PFI 537PFI 538PFI 539PFI 540PFI 541PFI 542PFI 543PFI 544PFI 545PFI 546PFI 547PFI 548PFI 549PFI 550PFI 551PFI 552PFI 553PFI 554PFI 555PFI 556PFI 557PFI 558PFI 559PFI 560PFI 561PFI 562PFI 563PFI 564PFI 565PFI 566PFI 567PFI 568PFI 569PFI 570PFI 571PFI 572PFI 573PFI 574PFI 575PFI 576PFI 577PFI 578PFI 579PFI 580PFI 581PFI 582PFI 583PFI 584PFI 585PFI 586PFI 587PFI 588PFI 589PFI 590PFI 591PFI 592PFI 593PFI 594PFI 595PFI 596PFI 597PFI 598PFI 599PFI 600PFI 601PFI 602PFI 603PFI 604PFI 605PFI 606PFI 607PFI 608PFI 609PFI 610PFI 611PFI 612PFI 613PFI 614PFI 615PFI 616PFI 617PFI 618PFI 619PFI 620PFI 621PFI 622PFI 623PFI 624PFI 625PFI 626PFI 627PFI 628PFI 629PFI 630PFI 631PFI 632PFI 633PFI 634PFI 635PFI 636PFI 637PFI 638PFI 639PFI 640PFI 641PFI 642PFI 643PFI 644PFI 645PFI 646PFI 647PFI 648PFI 649PFI 650PFI 651PFI 652PFI 653PFI 654PFI 655PFI 656PFI 657PFI 658PFI 659PFI 660PFI 661PFI 662PFI 663PFI 664PFI 665PFI 666PFI 667PFI 668PFI 669PFI 670PFI 671PFI 672PFI 673PFI 674PFI 675PFI 676PFI 677PFI 678PFI 679PFI 680PFI 681PFI 682PFI 683PFI 684PFI 685PFI 686PFI 687PFI 688PFI 689PFI 690PFI 691PFI 692PFI 693PFI 694PFI 695PFI 696PFI 697PFI 698PFI 699PFI 700PFI 701PFI 702PFI 703PFI 704PFI 705PFI 706PFI 707PFI 708PFI 709PFI 710PFI 711PFI 712PFI 713PFI 714PFI 715PFI 716PFI 717PFI 718PFI 719PFI 720PFI 721PFI 722PFI 723PFI 724PFI 725PFI 726PFI 727PFI 728PFI 729PFI 730PFI 731PFI 732PFI 733PFI 734PFI 735PFI 736PFI 737PFI 738PFI 739PFI 740PFI 741PFI 742PFI 743PFI 744PFI 745PFI 746PFI 747PFI 748PFI 749PFI 750PFI 751PFI 752PFI 753PFI 754PFI 755PFI 756PFI 757PFI 758PFI 759PFI 760PFI 761PFI 762PFI 763PFI 764PFI 765PFI 766PFI 767PFI 768PFI 769PFI 770PFI 771PFI 772PFI 773PFI 774PFI 775PFI 776PFI 777PFI 778PFI 779PFI 780PFI 781PFI 782PFI 783PFI 784PFI 785PFI 786PFI 787PFI 788PFI 789PFI 790PFI 791PFI 792PFI 793PFI 794PFI 795PFI 796PFI 797PFI 798PFI 799PFI 800PFI 801PFI 802PFI 803PFI 804PFI 805PFI 806PFI 807PFI 808PFI 809PFI 810PFI 811PFI 812PFI 813PFI 814PFI 815PFI 816PFI 817PFI 818PFI 819PFI 820PFI 821PFI 822PFI 823PFI 824PFI 825PFI 826PFI 827PFI 828PFI 829PFI 830PFI 831PFI 832PFI 833PFI 834PFI 835PFI 836PFI 837PFI 838PFI 839PFI 840PFI 841PFI 842PFI 843PFI 844PFI 845PFI 846PFI 847PFI 848PFI 849PFI 850PFI 851PFI 852PFI 853PFI 854PFI 855PFI 856PFI 857PFI 858PFI 859PFI 860PFI 861PFI 862PFI 863PFI 864PFI 865PFI 866PFI 867PFI 868PFI 869PFI 870PFI 871PFI 872PFI 873PFI 874PFI 875PFI 876PFI 877PFI 878PFI 879PFI 880PFI 881PFI 882PFI 883PFI 884PFI 885PFI 886PFI 887PFI 888PFI 889PFI 890PFI 891PFI 892PFI 893PFI 894PFI 895PFI 896PFI 897PFI 898PFI 899PFI 900PFI 901PFI 902PFI 903PFI 904PFI 905PFI 906PFI 907PFI 908PFI 909PFI 910PFI 911PFI 912PFI 913PFI 914PFI 915PFI 916PFI 917PFI 918PFI 919PFI 920PFI 921PFI 922PFI 923PFI 924PFI 925PFI 926PFI 927PFI 928PFI 929PFI 930PFI 931PFI 932PFI 933PFI 934PFI 935PFI 936PFI 937PFI 938PFI 939PFI 940PFI 941PFI 942PFI 943PFI 944PFI 945PFI 946PFI 947PFI 948PFI 949PFI 950PFI 951PFI 952PFI 953PFI 954PFI 955PFI 956PFI 957PFI 958PFI 959PFI 960PFI 961PFI 962PFI 963PFI 964PFI 965PFI 966PFI 967PFI 968PFI 969PFI 970PFI 971PFI 972PFI 973PFI 974PFI 975PFI 976PFI 977PFI 978PFI 979PFI 980PFI 981PFI 982PFI 983PFI 984PFI 985PFI 986PFI 987PFI 988PFI 989PFI 990PFI 991PFI 992PFI 993PFI 994PFI 995PFI 996PFI 997PFI 998PFI 999PFI 1000PFI

UY PIP BOARD SCHEMATIC DIAGRAM

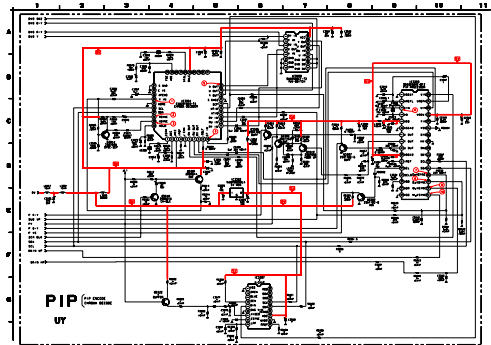

UY (PIP) BOARD (U) MARK LIST

REF. NO.	LOCATION	MARK	MARK
01	01-01	01-01	01-01
02	01-02	01-02	01-02
03	01-03	01-03	01-03
04	01-04	01-04	01-04
05	01-05	01-05	01-05
06	01-06	01-06	01-06
07	01-07	01-07	01-07
08	01-08	01-08	01-08
09	01-09	01-09	01-09
10	01-10	01-10	01-10
11	01-11	01-11	01-11
12	01-12	01-12	01-12
13	01-13	01-13	01-13
14	01-14	01-14	01-14
15	01-15	01-15	01-15
16	01-16	01-16	01-16
17	01-17	01-17	01-17
18	01-18	01-18	01-18
19	01-19	01-19	01-19
20	01-20	01-20	01-20
21	01-21	01-21	01-21
22	01-22	01-22	01-22
23	01-23	01-23	01-23
24	01-24	01-24	01-24
25	01-25	01-25	01-25
26	01-26	01-26	01-26
27	01-27	01-27	01-27
28	01-28	01-28	01-28
29	01-29	01-29	01-29
30	01-30	01-30	01-30
31	01-31	01-31	01-31
32	01-32	01-32	01-32
33	01-33	01-33	01-33
34	01-34	01-34	01-34
35	01-35	01-35	01-35
36	01-36	01-36	01-36
37	01-37	01-37	01-37
38	01-38	01-38	01-38
39	01-39	01-39	01-39
40	01-40	01-40	01-40
41	01-41	01-41	01-41
42	01-42	01-42	01-42
43	01-43	01-43	01-43
44	01-44	01-44	01-44
45	01-45	01-45	01-45
46	01-46	01-46	01-46
47	01-47	01-47	01-47
48	01-48	01-48	01-48
49	01-49	01-49	01-49
50	01-50	01-50	01-50
51	01-51	01-51	01-51
52	01-52	01-52	01-52
53	01-53	01-53	01-53
54	01-54	01-54	01-54
55	01-55	01-55	01-55
56	01-56	01-56	01-56
57	01-57	01-57	01-57
58	01-58	01-58	01-58
59	01-59	01-59	01-59
60	01-60	01-60	01-60
61	01-61	01-61	01-61
62	01-62	01-62	01-62
63	01-63	01-63	01-63
64	01-64	01-64	01-64
65	01-65	01-65	01-65
66	01-66	01-66	01-66
67	01-67	01-67	01-67
68	01-68	01-68	01-68
69	01-69	01-69	01-69
70	01-70	01-70	01-70
71	01-71	01-71	01-71
72	01-72	01-72	01-72
73	01-73	01-73	01-73
74	01-74	01-74	01-74
75	01-75	01-75	01-75
76	01-76	01-76	01-76
77	01-77	01-77	01-77
78	01-78	01-78	01-78
79	01-79	01-79	01-79
80	01-80	01-80	01-80
81	01-81	01-81	01-81
82	01-82	01-82	01-82
83	01-83	01-83	01-83
84	01-84	01-84	01-84
85	01-85	01-85	01-85
86	01-86	01-86	01-86
87	01-87	01-87	01-87
88	01-88	01-88	01-88
89	01-89	01-89	01-89
90	01-90	01-90	01-90
91	01-91	01-91	01-91
92	01-92	01-92	01-92
93	01-93	01-93	01-93
94	01-94	01-94	01-94
95	01-95	01-95	01-95
96	01-96	01-96	01-96
97	01-97	01-97	01-97
98	01-98	01-98	01-98
99	01-99	01-99	01-99
100	01-100	01-100	01-100

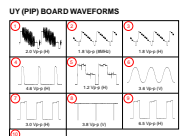

UY (PIP) BOARD TRANSISTOR VOLTAGE LIST

REF. NO.	LOCATION	VOLTAGE	UNIT
01	01-01	0.0	V
02	01-02	0.0	V
03	01-03	0.0	V
04	01-04	0.0	V
05	01-05	0.0	V
06	01-06	0.0	V
07	01-07	0.0	V
08	01-08	0.0	V
09	01-09	0.0	V
10	01-10	0.0	V
11	01-11	0.0	V
12	01-12	0.0	V
13	01-13	0.0	V
14	01-14	0.0	V
15	01-15	0.0	V
16	01-16	0.0	V
17	01-17	0.0	V
18	01-18	0.0	V
19	01-19	0.0	V
20	01-20	0.0	V
21	01-21	0.0	V
22	01-22	0.0	V
23	01-23	0.0	V
24	01-24	0.0	V
25	01-25	0.0	V
26	01-26	0.0	V
27	01-27	0.0	V
28	01-28	0.0	V
29	01-29	0.0	V
30	01-30	0.0	V
31	01-31	0.0	V
32	01-32	0.0	V
33	01-33	0.0	V
34	01-34	0.0	V
35	01-35	0.0	V
36	01-36	0.0	V
37	01-37	0.0	V
38	01-38	0.0	V
39	01-39	0.0	V
40	01-40	0.0	V
41	01-41	0.0	V
42	01-42	0.0	V
43	01-43	0.0	V
44	01-44	0.0	V
45	01-45	0.0	V
46	01-46	0.0	V
47	01-47	0.0	V
48	01-48	0.0	V
49	01-49	0.0	V
50	01-50	0.0	V
51	01-51	0.0	V
52	01-52	0.0	V
53	01-53	0.0	V
54	01-54	0.0	V
55	01-55	0.0	V
56	01-56	0.0	V
57	01-57	0.0	V
58	01-58	0.0	V
59	01-59	0.0	V
60	01-60	0.0	V
61	01-61	0.0	V
62	01-62	0.0	V
63	01-63	0.0	V
64	01-64	0.0	V
65	01-65	0.0	V
66	01-66	0.0	V
67	01-67	0.0	V
68	01-68	0.0	V
69			

6-8. SEMICONDUCTORS

D1NL20U
D2L20U
EL1Z
EGP20G
EGP30G
ERA22-08
ERC06-15S
ERD29-08J
EZ0150AV1
GP08D
MTZJ-33A
1SS83

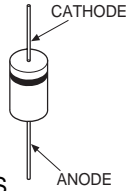

D1NS4
MTZJ-XXA
MTZJ-XXB
MTZJ-XXC
RDXXESB1
RDXXESB2
RDXXESB3
1SS119-25
1SS133T-77
(XX = VALUE)

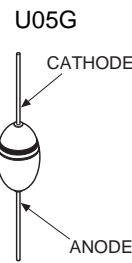
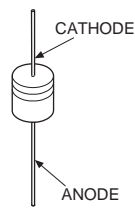

2SA1837
2SC4159-E
2SC4793
2SD2012

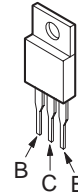

2SC4834M

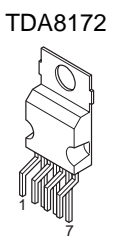
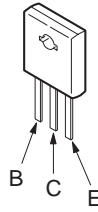

SBX1981

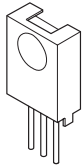

TDA2009A
TDA7262

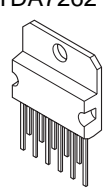

NJM78M05FA
PQ09RF21
TA7805S
BA05T

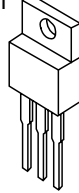

IC LINK
2A/90V



D10SC4M



2SC3209LK



2SK2845-LB102

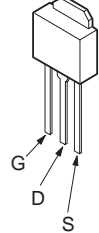

TSC5148
(LE SONY)

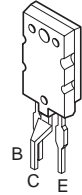

2SA1175-HFE
2SA933AS-QRT
2SC2785-HFE

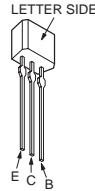

D10SBS4F
D6SB60L
D4SB60L

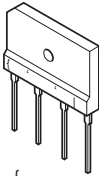

S-80748AL

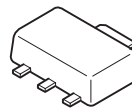

MA111
RD3.3SB
1SS355

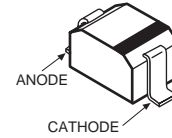

MX0842B-F

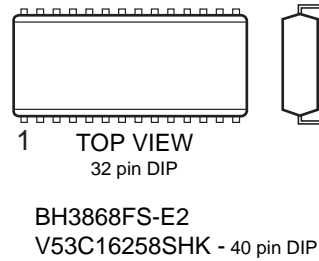
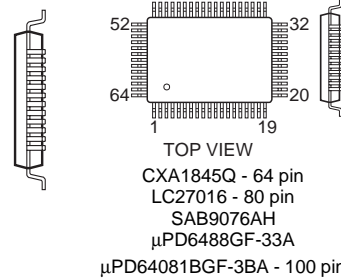
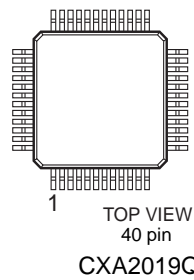
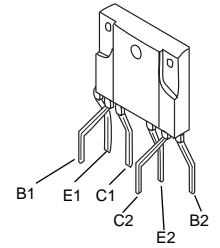

2SA1037K-T146-R
2SA1162-G
2SA1330-06
2SB709A
2SC1623-L5L6
2SD601A-Q

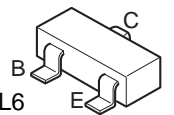

8 pin SOP
NJM2903D
NJM2903M
NJM2904D
ST24C02FM6TR
 μ PC4558G2
X24C04SB

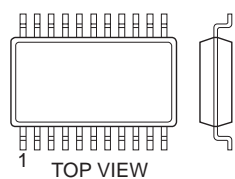

20 pin SOP
NJM2150M

16 pin SOP
BU4053BCF-T2
CXA1315M
MC14052BF
MC14538B
NJM2145M-TE2
CXD2064Q-T6

24 pin SOP
CXA2039M-T6
28 pin SOP
MN47V76ST1
MN47V77ST1
36 pin SOP
 μ PC1862GS-E2

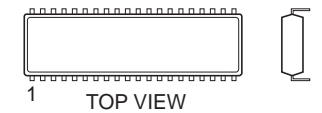
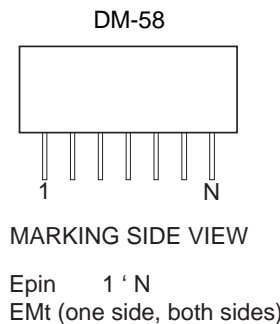

14 pin DIP
NJM2902M
16 pin DIP
MM1093N
20 pin DIP
TA1226N
22 pin DIP
CXA2021S
28 pin DIP
TDA7467
30 pin DIP
CXD2073S

40 pin DIP
SDA9288XE
42 pin DIP
MM1311AD
MM1313AD
48 pin DIP
CXA2131S
64 pin DIP
CXP85856A-029S

SECTION 7 EXPLODED VIEW

- Items with no part number and no description are not stocked because they are seldom required for routine service.
- The component parts of an assembly are indicated by the reference numbers in the remarks column.
- Items marked with an asterisk " * " are not stocked since they are seldom required for routine service. Some delay should be anticipated when ordering these items.

The components identified by shading and "△" are critical for safety. Replace only with specified part number.

Les composants identifiés par un trame et une marque △ sont critiques pour la sécurité. Ne les remplacer que par une pièce portant le numéro spécifique.

7-1. CHASSIS (KV-32FS10/32FV15/32FV15C/32XBR250/34FV10 34FV15/34FV15K/34FV15T/34FX250C)

- | | | |
|---|--------------|---|
| ■ | 7-682-566-04 | SCREW (M4X20), TAPPING, (+-)(BV) (KV-32FS10, 34FV10 EXCLUDED) |
| □ | 7-685-648-79 | SCREW (3X12, TYPE 2) |
| ● | 7-685-663-79 | SCREW (4X16, TYPE 2) |
| ○ | 7-685-871-01 | SCREW (3X6) (S) (KV-32XBR250, 34FX250C ONLY) |

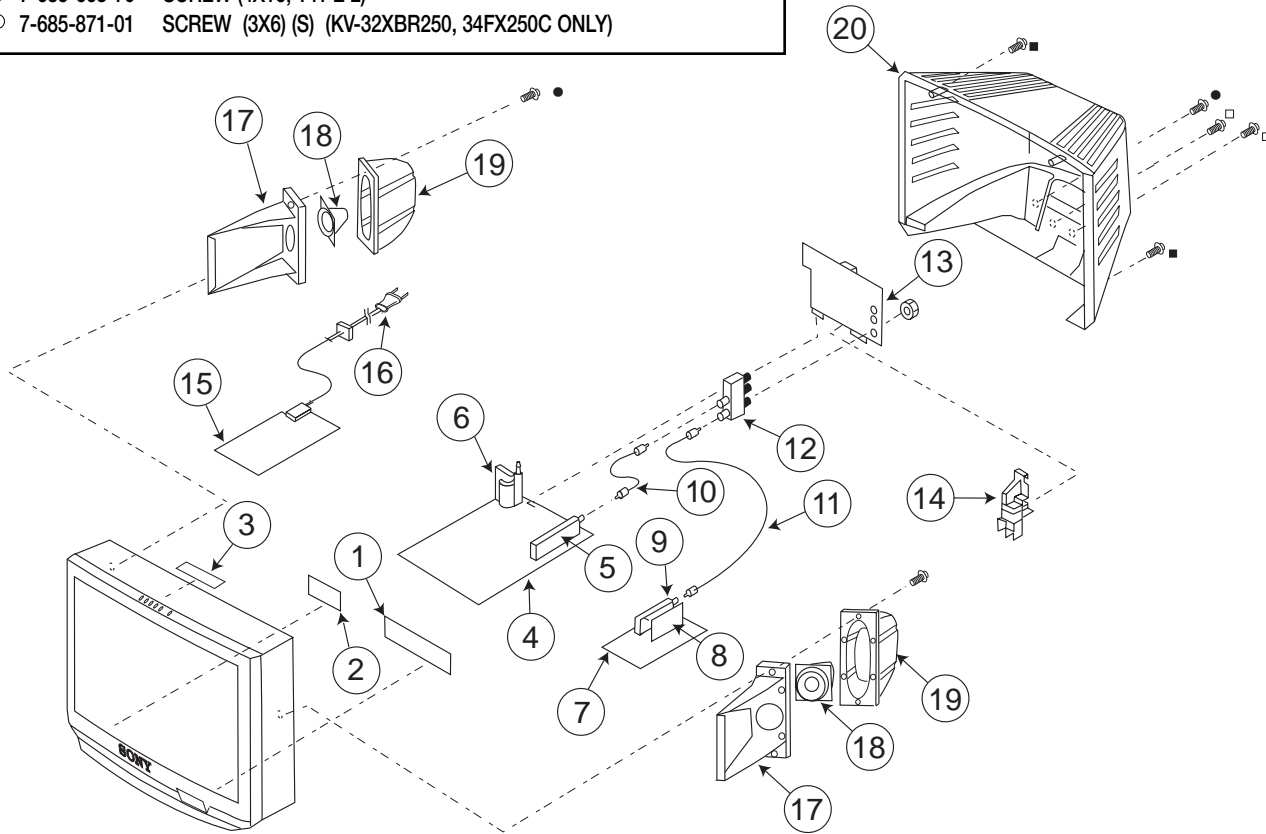

REF.NO.	PART NO.	DESCRIPTION	REMARK	REF.NO.	PART NO.	DESCRIPTION	REMARK
1	* A-1372-634-A	HA BOARD, COMPLETE		5	△ 8-598-477-00	TUNER, FSS BTF-WG411 (KV-34FV15T Only)	
2	* A-1372-635-A	HB BOARD, COMPLETE		6	△ 1-453-286-11	FBT ASSY, NX4600//X4C4	
3	* A-1372-636-A	HX BOARD, COMPLETE		7	* A-1298-956-A	AK BOARD, COMPLETE (KV-32FS10/34FV10 Only)	
4	* A-1298-890-A	A BOARD, COMPLETE (KV-32FS10/32FV15/32XBR250/34FV10/34FV15/34FV15C/34FX250C Only)		7	* A-1298-957-A	AK BOARD, COMPLETE (KV32FV15/34FV15/34FV15C/34FV15K/34FV15T Only)	
4	* A-1298-965-A	A BOARD, COMPLETE (KV34FV15T Only)		7	* A-1298-980-A	AK BOARD, COMPLETE (KV-32XBR250/34FX250C Only)	
4	* A-1298-969-A	A BOARD, COMPLETE (KV34FV15K Only)		8	* A-1394-934-A	T BOARD, COMPLETE (KV-32XBR250/34FX250C Only)	
5	△ 8-598-431-00	TUNER, FSS BTF-WA411 (KV-32FS10/32FV15/32XBR250/34FV10/34FV15/34FV15C/34FX250C Only)		9	△ 8-598-430-00	TUNER, BTF-FA401	
5	△ 8-598-475-00	TUNER, FSS BTF-WL411 (KV-34FV15K Only)		10	1-557-056-31	CABLE, P-P (KV-32FV15/32XBR250/34FV15/34FV15C/34FV15K/34FV15T/34FX250C Only)	

The components identified by shading and "△" are critical for safety. Replace only with specified part number.

Les composants identifiés par un trame et une marque △ sont critiques pour la sécurité. Ne les remplacer que par une pièce portant le numéro spécifié.

REF.NO.	PART NO.	DESCRIPTION	REMARK	REF.NO.	PART NO.	DESCRIPTION	REMARK
11	1-556-945-21	CABLE, P-P (KV-32FV15/32XBR250/34FV15/34FV15C/34FV15K/34FV15T/34FX250C Only)		16	△1-769-796-71	CORD, POWER (WITH CONNECTOR) (KV-34FV15C/34FX250C Only)	
12	8-598-414-10	ANTENNA CHANGER AS-2F (KV-32FV15/32XBR250/34FV15/34FV15C/34FV15K/34FV15T/34FX250C Only)		16	△1-775-468-11	CORD, POWER (WITH CONNECTOR) (KV-34FV15K Only)	
13	* A-1394-947-A	UX BOARD, COMPLETE (KV-32XBR250 Only)		16	△1-790-315-21	CORD, AC POWER (WITH CONNECTOR) (KV-34FV10/34FV15 Only)	
13	* A-1394-948-A	UY BOARD, COMPLETE KV-34FX250C Only)		16	△1-790-317-21	CORD, AC POWER (WITH CONNECTOR) (KV-32FS10/32FV15/32XBR250/34FV15T Only)	
13	* A-1394-938-A	UY BOARD, COMPLETE (KV-32FS10/34FV10 Only)		17	* 4-068-988-01	BAFFLE, SPEAKER	
13	* A-1394-943-A	UY BOARD, COMPLETE (KV-32FV15 Only)		18	1-529-336-11	SPEAKER (1-WAY) (KV-32FS10/32FV15/34FV15K/34FV15T Only)	
13	* A-1394-944-A	UY BOARD, COMPLETE (KV-34FV15/34FV15C/34FV15K/34FV15T Only)		18	1-529-358-11	SPEAKER (2-WAY) (KV-32XBR250/34FV10/34FV15/34FV15C/34FX250C Only)	
14	3-696-606-02	HINGE, VI		19	* 4-068-987-01	BOX, SPEAKER	
15	* A-1316-397-A	G BOARD, COMPLETE (KV-32FS10/32FV15/32XBR250 Only)		20	4-069-000-01	COVER, REAR (KV-32FV15/32XBR250/34FV15T/34FX250C Only)	
15	* A-1316-423-A	G BOARD, COMPLETE (KV-34FV15T Only)		20	4-069-000-21	COVER, REAR (KV-32FS10/34FV10/34FV15, 34FV15C/34FV15K Only)	
15	* A-1316-470-A	GA BOARD, COMPLETE (KV-34FV10/34FV15/34FV15C/34FV15K/34FX250C Only)					

The components identified by shading and "△" are critical for safety. Replace only with specified part number.

Les composants identifiés par un trame et une marque △ sont critiques pour la sécurité. Ne les remplacer que par une pièce portant le numéro spécifié.

7-2. CHASSIS (KV-36FS10/36FV15/36XBR250/38FV15K/38FX250/38FX250C/38FX250T)

- 7-682-566-04 SCREW (M4X20), TAPPING, (+-)(BV) (KV-36FV15, 36XBR250, 38FV15K, 38FX250, 38FX250C, 38FX250T ONLY)
- 7-685-648-79 SCREW (3X12, TYPE 2)
- 7-685-663-79 SCREW (4X16, TYPE 2)
- 7-685-871-01 SCREW (3X6) (S) (KV-36XBR250, 38FX250, 38FX250C 38FX250T ONLY)

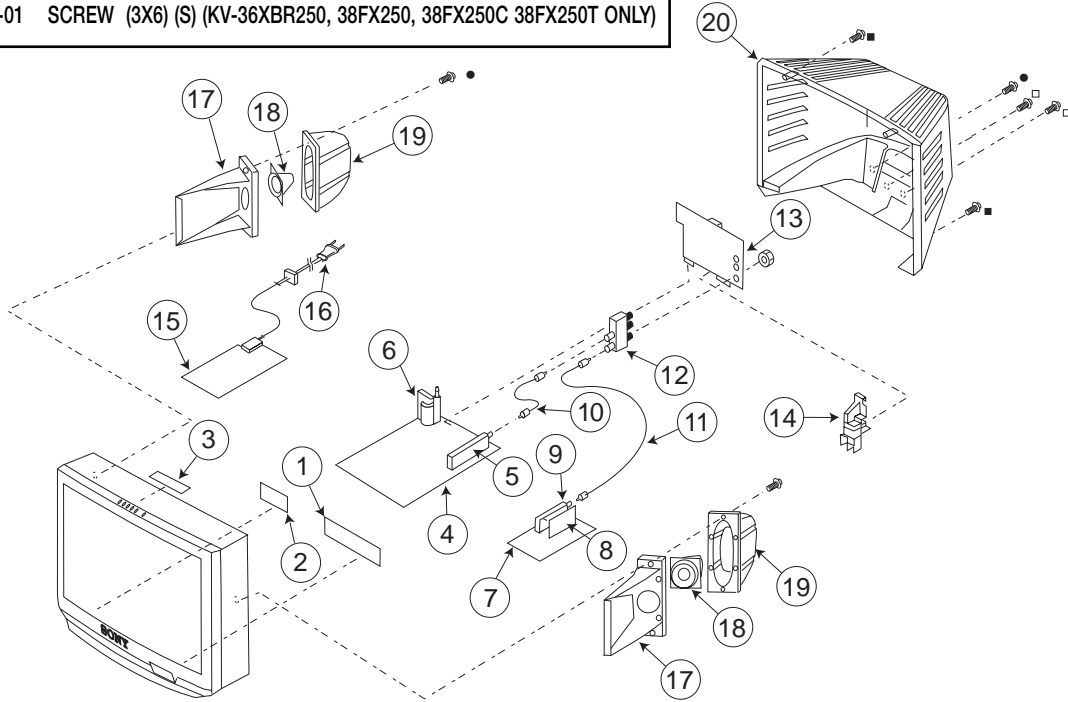

REF.NO.	PART NO.	DESCRIPTION	REMARK	REF.NO.	PART NO.	DESCRIPTION	REMARK
1	* A-1372-634-A	HA BOARD, COMPLETE		13	* A-1394-938-A	UY BOARD, COMPLETE (KV-36FS10 Only)	
2	* A-1372-635-A	HB BOARD, COMPLETE		13	* A-1394-943-A	UY BOARD, COMPLETE (KV-36FV15 Only)	
3	* A-1372-636-A	HX BOARD, COMPLETE		13	* A-1394-944-A	UY BOARD, COMPLETE (KV-38FV15K Only)	
4	* A-1298-961-A	A BOARD, COMPLETE (KV-36FS10/36FV15/ 36XBR250/38FX250/38FX250C Only)		13	* A-1394-947-A	UX BOARD, COMPLETE (KV-36XBR250 Only)	
4	* A-1298-993-A	A BOARD, COMPLETE (KV-38FV15K Only)		13	* A-1394-948-A	UX BOARD, COMPLETE (KV-38FX250/38FX250C/38FX250T Only)	
4	* A-1298-994-A	A BOARD, COMPLETE (KV-38FX250T Only)		14	3-696-606-02	HINGE, VI	
5	△ 8-598-431-00	TUNER, FSS BTF-WA411 (KV-36FS10/36FV15/ 36XBR250/38FX250/38FX250C Only)		15	* A-1316-397-A	G BOARD, COMPLETE (KV-36FS10/ 36FV15/36XBR250 Only)	
5	△ 8-598-475-00	TUNER, FSS BTF-WL411 (KV-38FV15K Only)		15	* A-1316-423-A	G BOARD, COMPLETE (KV-38FX250T Only)	
5	△ 8-598-477-00	TUNER, FSS BTF-WG411 (KV-38FX250T Only)		15	* A-1316-470-A	GA BOARD, COMPLETE (KV-38FV15K/38FX250/38FX250C Only)	
6	△ 1-453-286-11	FBT ASSY, NX4600/X4C4		16	△ 1-769-796-71	CORD, POWER (WITH CONNECTOR) (KV-38FX250/38FX250C Only)	
7	* A-1298-956-A	AK BOARD, COMPLETE (KV-36FS10 Only)		16	△ 1-775-468-11	CORD, POWER (WITH CONNECTOR) (KV-38FV15K Only)	
7	* A-1298-957-A	AK BOARD, COMPLETE (KV-36FV15/ 38FV15K Only)		16	△ 1-790-317-21	CORD, AC POWER (WITH CONNECTOR) (KV-36FS10/36FV15/36XBR250/38FX250T Only)	
7	* A-1298-980-A	AK BOARD, COMPLETE (KV-36XBR250/ 38FX250/38FX250C/38FX250T Only)		17	* 4-068-988-01	BAFFLE, SPEAKER	
8	* A-1394-934-A	T BOARD, COMPLETE (KV-36XBR250/ 38FX250/38FX250C/38FX250T Only)		18	1-529-336-11	SPEAKER (1-WAY) (KV-36FS10/ 36FV15/38FV15K Only)	
9	△ 8-598-430-00	TUNER, FSS BTF-FA401		18	1-529-358-11	SPEAKER (2-WAY) (KV-36XBR250/ 38FX250/38FX250C/38FX250T Only)	
10	1-557-056-31	CABLE, P-P (KV-36FV15/36XBR250/38FV15K/ 38FX250/38FX250C/38FX250T Only)		19	* 4-068-987-01	BOX, SPEAKER	
11	1-556-945-21	CABLE, P-P (KV-36FV15/36XBR250/38FV15K/ 38FX250/38FX250C/38FX250T Only)		20	4-068-998-01	COVER, REAR (KV-36FS10/36FV15/36XBR250, 38FV15K/38FX250/38FX250C/38FX250T Only)	
12	8-598-414-10	ANTENNA CHANGER AS-2F (KV-36FV15/ 36XBR250/38FV15K/38FX250/38FX250C/ 38FX250T Only)					

The components identified by shading and "Δ" mark are critical for safety. Replace only with specified part number.

Les composants identifiés par un trame et une marque Δ sont critiques pour la sécurité. Ne les remplacer que par une pièce portant le numéro spécifié.

7-3. PICTURE TUBE

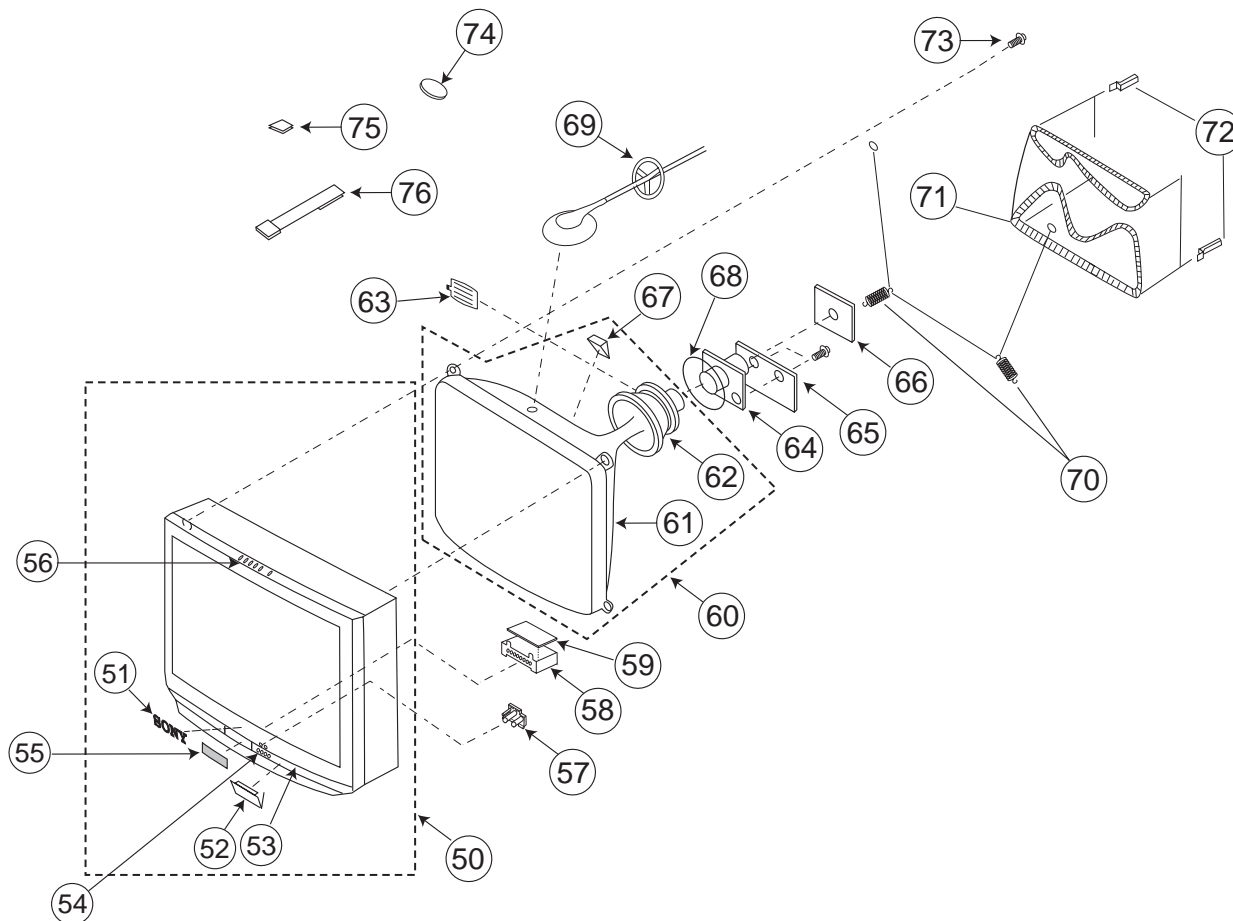

REF.NO.	PART NO.	DESCRIPTION	REMARK	REF.NO.	PART NO.	DESCRIPTION	REMARK
50	X-4036-678-2	BEZNET ASSY (KV-32FS10 Only)	51-53	54	4-068-984-01	MULTI-BUTTON (BOTTOM)	
50	X-4036-679-1	BEZNET ASSY (KV-32FV15/34FV15T Only)	51-53	55	4-068-991-01	PANEL, IR (KV-32XBR250/34FX250C/36XBR250, 38FX250/38FX250C/38FX250T Only)	
50	X-4036-679-2	BEZNET ASSY (KV-34FV10/34FV15/34FV15C/ 34FV15K Only)	51-53	56	4-068-982-01	MULTI-BUTTON (TOP)	
50	X-4036-680-1	BEZNET ASSY (KV-32XBR250/34FX250C Only)	51-53	57	* 4-068-986-01	GUIDE, LED	
50	X-4036-683-1	BEZNET ASSY (KV-36FS10 Only)	51-53	58	4-068-992-01	CASE, IR SHIELD (KV-32XBR250/34FX250C/36XBR250, 38FX250/38FX250C/38FX250T Only)	
50	X-4036-684-1	BEZNET ASSY 36FV15/38FV15K Only)	51-53	59	4-071-399-01	CUSHION, 45MM X 100MM (KV-36XBR250/38FX250/38FX250C/ 38FX250T Only)	
50	X-4036-685-1	BEZNET ASSY (KV-36XBR250/38FX250/38FX250C, 38FX250T Only)	51-53	60 Δ	8-735-047-61	ITC 34RSN-A1	61-62
51	3-704-179-31	EMBLEM (NO. 9), SONY		60 Δ	8-735-050-61	ITC 34RSN-A1E (KV-34FX250C ONLY)	61-62
52	4-068-985-01	DOOR		60 Δ	8-735-048-61	ITC 38RSN-A1	61-62
53	3-703-574-00	RETAINER, DOOR				(KV-36FS10/36FV15/36XBR250/38FV15K/ 38FX250/38FX250T Only)	

The components identified by shading and "△" mark are critical for safety. Replace only with specified part number.

Les composants identifiés par un trame et une marque △ sont critiques pour la sécurité. Ne les remplacer que par une pièce portant le numéro spécifié.

REF.NO.	PART NO.	DESCRIPTION	REMARK	REF.NO.	PART NO.	DESCRIPTION	REMARK
60	△ 8-735-080-61	ITC 38RSN-A1E (KV-38FX250C Only)	61-62	69	3-704-372-31	HOLDER, HV CABLE	
61	△ 8-735-047-05	CRT 34RSN (KV-32FS10/34FV10/34FV15/ 34FV15C/34FV15K/34FV15T Only)		70	4-036-329-01	SPRING (B), TENSION	
62	△ 8-451-499-21	DY Y34RSA-X (KV-32FS10/34FV10/34FV15/ 34FV15C/34FV15K/34FV15T Only)		71	△ 1-419-163-11	COIL, DEMAGNETIZATION (KV-34FV10/34FV15/34FV15C/34FV15K/ 34FX250C Only)	
63	2-163-920-01	PLATE, TLH CORRECTION (KV-32FS10/34FV10/34FV15/34FV15C/ 34FV15K/34FV15T Only)		71	△ 1-419-193-11	COIL, DEMAGNETIZATION (KV-38FV15K/38FX250/38FX250C Only)	
64	△ 8-453-007-41	NA324-M4 (KV-32FS10/34FV10/34FV15/ 34FV15C/34FV15K/34FV15T Only)		71	△ 1-416-827-11	COIL, DEMAGNETIZATION (KV-32FS10/32FV15/32XBR250/34FV15T Only)	
65	* A-1375-187-A	WA BOARD, MOUNTED (KV-32FS10/32FV15/ 32XBR250/34FV10/34FV15/34FV15K/ 34FV15T/34FX250C Only)		71	△ 1-416-828-11	COIL, DEMAGNETIZATION (KV-36FS10/36FV15/36XBR250/ 38FX250T Only)	
65	* A-1375-191-A	WA BOARD, MOUNTED (KV-36FS10/36FV15/ 36XBR250/36XBR250C/38FV15K/38FX250/ 38FX250C/38FX250T Only)		72	4-065-895-02	HOLDER, DGC	
66	* A-1331-942-A	C BOARD, COMPLETE		73	4-046-765-01	SCREW, TAPPING (7) +CROWN WASHER	
67	4-053-005-01	SPACER, DY (KV-32FS10/34FV10/34FV15/ 34FV15C/34FV15K/34FV15T Only)		74	1-452-094-00	DISC, CIRCULAR (KV-32FS10/34FV10/ 34FV15/34FV15C/34FV15K/34FV15T Only)	
68	1-452-896-11	COIL, NA ROTATION (KV-32FS10/34FV15/ 34FV15C/34FV15K/34FV15T Only)		75	1-452-032-00	MAGNET, DISC (KV-32FS10/34FV10/34FV15/34FV15C, 34FV15K/34FV15T Only)	
				76	4-062-047-01	PIECE A (110), CONV CORRECT (KV-32FS10/34FV10/34FV15/34FV15C/ 34FV15K/34FV15T Only)	

SECTION 8 ELECTRICAL PARTS LIST

PARTS LISTING TABLE OF CONTENTS
--

	Page
A BOARD <u>COMPLETE</u> PARTS LIST: (All Models)	85
AK BOARD <u>COMMON</u> PARTS LIST: Parts common to <u>all</u> models listed in this manual	92
AK BOARD <u>VARIANT</u> PARTS LIST: Parts that belong <u>only</u> to the model specified	95
Refer to the designated variant parts list when seeking a part indicated by an asterisk (*) on the A board schematic or by the word "variant" on the common parts list.	
<u>Model</u>	<u>Page</u>
KV-32FV15/34FV15/34FV15C/34FV15K/34FV15T/36FV15/38FV15K	95
KV-32XBR250/34FX250C/36XBR250/38FX250/38FX250C/38FX250T	96
C BOARD <u>COMPLETE</u> PARTS LIST (All Models)	97
G BOARD <u>COMPLETE</u> PARTS LIST (KV-32FS10/32FV15/32XBR250/34FV15T/36FS10/36FV15/36XBR250/38FX250T only)	97
GA BOARD <u>COMPLETE</u> PARTS LIST (KV-34FV10/34FV15/34FV15C/34FV15K/34FX250C/38FX250/38FX250C/38FV15K only)	100
HA BOARD <u>COMPLETE</u> PARTS LIST (All Models)	103
HB BOARD <u>COMPLETE</u> PARTS LIST (All Models)	103
HX BOARD <u>COMPLETE</u> PARTS LIST (All Models)	103
T BOARD <u>COMPLETE</u> PARTS LIST (KV-32XBR250/34FX250C/36XBR250/38FX250/38FX250C/38FX250T only)	104
UX BOARD <u>MAIN</u> PARTS LIST (KV-32XBR250/34FX250C/36XBR250/38FX250/38FX250C/38FX250T only)	106
UX BOARD <u>PIP</u> PARTS LIST (KV-32XBR250/34FX250C/36XBR250/38FX250/38FX250C/38FX250T only)	112
UY BOARD <u>MAIN</u> PARTS LIST (32FS10/32FV15/34FV10/34FV15/34FV15C/34FV15K/34FV15T/36FS10/36FV15/38FV15K only)	114
UY BOARD <u>PIP</u> PARTS LIST (32FS10/32FV15/34FV10/34FV15/34FV15C/34FV15K/34FV15T/36FS10/36FV15/38FV15K only)	119
WA BOARD <u>COMPLETE</u> PARTS LIST (All Models)	121
ACCESSORIES AND PACKING MATERIAL	123
REMOTE COMMANDER	123

A**COMPLETE PARTS LISTING**

The components identified by shading and mark Δ are critical for safety. Replace only with part number specified.

Les composants identifiés par un trame et une marque Δ sont critiques pour la sécurité. Ne les remplacer que par une pièce portant le numéro spécifié.

REF.NO.	PART NO.	DESCRIPTION	REMARK	REF.NO.	PART NO.	DESCRIPTION	REMARK
C396	1-163-021-91	CERAMIC CHIP	0.01 μ F 10% 50V	C565	1-126-969-11	ELECT	220 μ F 20% 50V
C397	1-104-664-11	ELECT	47 μ F 20% 25V	C568	1-136-169-00	FILM	0.22 μ F 5% 50V
C398	1-126-961-11	ELECT	2.2 μ F 20% 50V	C571	1-126-942-61	ELECT	1000 μ F 20% 25V
C501	1-102-110-00	CERAMIC	220pF 10% 50V	C572	1-126-942-61	ELECT	1000 μ F 20% 25V
C502	1-126-959-11	ELECT	0.47 μ F 20% 50V	C1002	1-126-964-11	ELECT	10 μ F 20% 50V
C503	1-163-133-00	CERAMIC CHIP	470pF 5% 50V	C1003	1-126-961-11	ELECT	2.2 μ F 20% 50V
C504	1-102-228-00	CERAMIC	470pF 10% 500V	C1004	1-126-960-11	ELECT	1 μ F 20% 50V
C505	1-102-228-00	CERAMIC	470pF 10% 500V	C1101	1-126-943-11	ELECT	2200 μ F 20% 25V
C506	1-106-383-00	MYLAR	0.047 μ F 10% 200V	C1103	1-126-965-11	ELECT	22 μ F 20% 50V
C507 Δ	1-162-116-00	CERAMIC	680pF 10% 2KV	C1104	1-104-664-11	ELECT	47 μ F 20% 25V
C508	1-102-228-00	CERAMIC	470pF 10% 500V	C1105	1-104-664-11	ELECT	47 μ F 20% 25V
C509	1-162-116-00	CERAMIC	680pF 10% 2KV	C1106	1-126-964-11	ELECT	10 μ F 20% 50V
C510	1-137-150-11	MYLAR	0.01 μ F 10% 100V	C1107	1-163-037-11	CERAMIC CHIP	0.022 μ F 10% 50V
C511 Δ	1-117-652-11	FILM	22000pF 3% 2KV	C1108	1-128-551-11	ELECT	22 μ F 20% 25V
C512	1-129-928-00	FILM	0.0027 μ F 10% 630V	C1109	1-126-964-11	ELECT	10 μ F 20% 50V
C513 Δ	1-130-118-00	FILM	0.051 μ F 5% 400V	C1110	1-163-227-11	CERAMIC CHIP	10pF 0.5pF 50V
C514 Δ	1-115-521-11	FILM	0.82 μ F 5% 250V	C1111	1-163-227-11	CERAMIC CHIP	10pF 0.5pF 50V
C515	1-106-343-00	MYLAR	0.001 μ F 10% 100V	C1112	1-163-227-11	CERAMIC CHIP	10pF 0.5pF 50V
C516	1-136-540-11	FILM	0.82 μ F 5% 200V	C1117	1-126-960-11	ELECT	1 μ F 20% 50V
C517	1-107-649-11	ELECT	2.2 μ F 20% 250V	C1118	1-126-960-11	ELECT	1 μ F 20% 50V
C518	1-106-387-00	MYLAR	0.068 μ F 10% 200V	C1355	1-163-009-11	CERAMIC CHIP	0.001 μ F 10% 50V
C519	1-107-612-11	CERAMIC	100pF 5% 500V	C1356	1-126-964-11	ELECT1	10 μ F 20% 50V
C520	1-164-646-11	CERAMIC	2200pF 10% 500V	C1357	1-164-005-11	CERAMIC CHIP	0.47 μ F 16V
C521	1-163-010-11	CERAMIC CHIP	0.0012 μ F 10% 50V	C1358	1-126-940-11	ELECT	330 μ F 20% 25V
C522	1-126-960-11	ELECT	1 μ F 20% 50V	C1359	1-163-038-91	CERAMIC CHIP	0.1 μ F 25V
C525	1-102-244-00	CERAMIC	220pF 10% 500V	C1360	1-163-031-11	CERAMIC CHIP	0.01 μ F 50V
C526	1-107-662-11	ELECT	22 μ F 20% 250V	C1361	1-163-241-11	CERAMIC CHIP	39pF 5% 50V
C527	1-162-116-00	CERAMIC	680pF 10% 2KV	C1362	1-163-017-00	CERAMIC CHIP	0.0047 μ F 10% 50V
C528	1-164-161-11	CERAMIC CHIP	0.0022 μ F 10% 50V	C1363	1-163-031-11	CERAMIC CHIP	0.01 μ F 50V
C529	1-128-551-11	ELECT	22 μ F 20% 25V	C1367	1-163-038-91	CERAMIC CHIP	0.1 μ F 25V
C530	1-137-366-11	FILM	0.0022 μ F 5% 50V	C1369	1-163-038-91	CERAMIC CHIP	0.1 μ F 25V
C531	1-126-965-11	ELECT	22 μ F 20% 50V	C1370	1-126-964-11	ELECT	10 μ F 20% 50V
C532	1-126-965-11	ELECT	22 μ F 20% 50V	C1371	1-163-017-00	CERAMIC CHIP	0.0047 μ F 10% 50V
C534	1-126-967-11	ELECT	47 μ F 20% 50V	C1372	1-163-017-00	CERAMIC CHIP	0.0047 μ F 10% 50V
C537	1-126-941-11	ELECT	470 μ F 20% 25V	C1373	1-163-133-00	CERAMIC CHIP	470pF 5% 50V
C539	1-126-941-11	ELECT	470 μ F 20% 25V	C1501 Δ	1-107-846-11	FILM	0.1 μ F 5% 250V
C540	1-107-995-11	ELECT	100 μ F 0 160V				
C541	1-128-560-11	ELECT	22 μ F 20% 100V				
C543	1-104-666-11	ELECT	220 μ F 20% 25V				
C544	1-129-718-00	FILM	0.022 μ F 5% 630V				
C545	1-106-387-00	MYLAR	0.068 μ F 10% 200V				
C546	1-106-343-00	MYLAR	0.001 μ F 10% 100V				
C547	1-106-343-00	MYLAR	0.001 μ F 10% 100V				
C548	1-164-004-11	CERAMIC CHIP	0.1 μ F 10% 25V				
C549	1-106-375-12	MYLAR	0.022 μ F 20% 200V				
C550	1-102-002-00	CERAMIC	680pF 10% 500V				
C551	1-109-954-11	ELECT	0.47 μ F 20% 160V				
C552	1-102-244-00	CERAMIC	220pF 10% 500V				
C553	1-117-665-11	FILM	0.33 μ F 5% 250V				
C554 Δ	1-104-491-11	FILM	0.0047 μ F 3% 2KV				
C561	1-126-967-11	ELECT	47 μ F 20% 50V				
C563	1-104-666-11	ELECT	220 μ F 20% 25V				
C564	1-126-960-11	ELECT	1 μ F 20% 50V				
C565	1-126-969-11	ELECT	220 μ F 20% 50V				
C568	1-136-169-00	FILM	0.22 μ F 5% 50V				
C571	1-126-942-61	ELECT	1000 μ F 20% 25V				
C572	1-126-942-61	ELECT	1000 μ F 20% 25V				
C1002	1-126-964-11	ELECT	10 μ F 20% 50V				
C1003	1-126-961-11	ELECT	2.2 μ F 20% 50V				
C1004	1-126-960-11	ELECT	1 μ F 20% 50V				
C1101	1-126-943-11	ELECT	2200 μ F 20% 25V				
C1103	1-126-965-11	ELECT	22 μ F 20% 50V				
C1104	1-104-664-11	ELECT	47 μ F 20% 25V				
C1105	1-104-664-11	ELECT	47 μ F 20% 25V				
C1106	1-126-964-11	ELECT	10 μ F 20% 50V				
C1107	1-163-037-11	CERAMIC CHIP	0.022 μ F 10% 50V				
C1108	1-128-551-11	ELECT	22 μ F 20% 25V				
C1109	1-126-964-11	ELECT	10 μ F 20% 50V				
C1110	1-163-227-11	CERAMIC CHIP	10pF 0.5pF 50V				
C1111	1-163-227-11	CERAMIC CHIP	10pF 0.5pF 50V				
C1112	1-163-227-11	CERAMIC CHIP	10pF 0.5pF 50V				
C1117	1-126-960-11	ELECT	1 μ F 20% 50V				
C1118	1-126-960-11	ELECT	1 μ F 20% 50V				
C1355	1-163-009-11	CERAMIC CHIP	0.001 μ F 10% 50V				
C1356	1-126-964-11	ELECT1	10 μ F 20% 50V				
C1357	1-164-005-11	CERAMIC CHIP	0.47 μ F 16V				
C1358	1-126-940-11	ELECT	330 μ F 20% 25V				
C1359	1-163-038-91	CERAMIC CHIP	0.1 μ F 25V				
C1360	1-163-031-11	CERAMIC CHIP	0.01 μ F 50V				
C1361	1-163-241-11	CERAMIC CHIP	39pF 5% 50V				
C1362	1-163-017-00	CERAMIC CHIP	0.0047 μ F 10% 50V				
C1363	1-163-031-11	CERAMIC CHIP	0.01 μ F 50V				
C1367	1-163-038-91	CERAMIC CHIP	0.1 μ F 25V				
C1369	1-163-038-91	CERAMIC CHIP	0.1 μ F 25V				
C1370	1-126-964-11	ELECT	10 μ F 20% 50V				
C1371	1-163-017-00	CERAMIC CHIP	0.0047 μ F 10% 50V				
C1372	1-163-017-00	CERAMIC CHIP	0.0047 μ F 10% 50V				
C1373	1-163-133-00	CERAMIC CHIP	470pF 5% 50V				
C1501 Δ	1-107-846-11	FILM	0.1 μ F 5% 250V				

CONNECTOR

CN270 *	1-691-616-21	CONNECTOR, BOARD TO BOARD	15P
CN271 *	1-691-616-21	CONNECTOR, BOARD TO BOARD	15P
CN272 *	1-691-616-21	CONNECTOR, BOARD TO BOARD	15P
CN351 *	1-564-509-11	PLUG, CONNECTOR	6P
CN501 *	1-580-798-11	CONNECTOR PIN (DY)	6P
CN503 *	1-564-508-11	PLUG, CONNECTOR	5P
CN1001*	1-564-508-11	PLUG, CONNECTOR	5P
CN1002*	1-564-506-11	PLUG, CONNECTOR	3P
CN1101*	1-564-515-11	PLUG, CONNECTOR	12P
CN1102*	1-564-507-11	PLUG, CONNECTOR	4P
CN1231*	1-564-512-11	PLUG, CONNECTOR	9P
CN1641*	1-564-515-11	PLUG, CONNECTOR	12P
CN1643	1-695-915-11	TAB (CONTACT)	
CN1941*	1-564-511-11	PLUG, CONNECTOR	8P
CN1942*	1-564-508-11	PLUG, CONNECTOR	5P

The components identified by shading and mark \triangle are critical for safety. Replace only with part number specified.

Les composants identifiés par un trame et une marque \triangle sont critiques pour la securite. Ne les remplacer que par une piece portant le numero specifie.

COMPLETE PARTS LISTING

A

REF.NO.	PART NO.	DESCRIPTION	REMARK	REF.NO.	PART NO.	DESCRIPTION	REMARK
DIODE							
D001	8-719-991-33	DIODE 1SS133T-77		D1302	8-719-991-33	DIODE 1SS133T-77	
D002	8-719-109-89	DIODE RD5.6ESB2		D1303	8-719-404-50	DIODE MA111-TX	
D003	8-719-991-33	DIODE 1SS133T-77		D1304	8-719-404-50	DIODE MA111-TX	
D004	8-719-110-17	DIODE RD10ESB2		D1305	8-719-404-50	DIODE MA111-TX	
D011	8-719-109-72	DIODE RD3.9ESB2		D1306	8-719-404-50	DIODE MA111-TX	
D012	8-719-991-33	DIODE 1SS133T-77		FERRITE BEAD			
D013	8-719-991-33	DIODE 1SS133T-77		FB501	1-410-397-21	FERRITE	1.1 μ H
D014	8-719-991-33	DIODE 1SS133T-77		FB502	1-410-397-21	FERRITE	1.1 μ H
D015	8-719-991-33	DIODE 1SS133T-77		FB503	1-410-397-21	FERRITE	1.1 μ H
D016	8-719-991-33	DIODE 1SS133T-77		IC			
D018	8-719-404-50	DIODE MA111-TX		IC001	8-752-903-74	IC CXP85856A-024Q	
D019	8-719-404-50	DIODE MA111-TX		IC002	8-759-527-76	IC M24C08-MN6T	
D301	8-719-404-50	DIODE MA111-TX		IC351	8-759-710-86	IC NJM2233BM	
D302	8-719-991-33	DIODE 1SS133T-77		IC352	8-752-080-75	IC CXA2039M-T6	
D303	8-719-921-44	DIODE MTZJ-5.1C		IC353	8-759-462-91	IC TA1226N	
D368	8-719-991-33	DIODE 1SS133T-77		IC354	8-752-082-49	IC CXA2119M	
D384	8-719-921-80	DIODE MTZJ-11B		IC355	8-752-088-86	IC CXA2131S	
D388	8-719-921-80	DIODE MTZJ-11B		IC501	8-759-700-07	IC NJM2903M	
D501	8-719-109-89	DIODE RD5.6ESB2		IC561 \triangle	8-759-192-71	IC STV9379	
D502	8-719-945-80	DIODE ERC06-15S		IC1001	8-752-058-68	IC CXA1315M	
D503 \triangle	8-719-945-80	DIODE ERC06-15S		CHIP CONDUCTOR			
D504	8-719-900-26	DIODE ERD29-08J		JR001	1-216-295-91	SHORT	
D505	8-719-908-03	DIODE GP08D		JR002	1-216-295-91	SHORT	
D506	8-719-908-03	DIODE GP08D		JR003	1-216-295-91	SHORT	
D507	8-719-991-33	DIODE 1SS133T-77		JR004	1-216-049-91	RES, CHIP	1K 5% 1/10W
D510	8-719-300-33	DIODE RU-3AM		JR051	1-216-295-91	SHORT	
D511	8-719-970-87	DIODE ERA38-06		JR053	1-216-295-91	SHORT	
D512	8-719-970-87	DIODE ERA38-06		JR054	1-216-295-91	SHORT	
D513	8-719-110-41	DIODE RD15ESB2		JR4120	1-216-295-91	SHORT	
D515 \triangle	8-719-302-43	DIODE EL1Z		COIL			
D516	8-719-991-33	DIODE 1SS133T-77		L001	1-414-857-11	INDUCTOR	100 μ H
D518	8-719-991-33	DIODE 1SS133T-77		L002	1-414-857-11	INDUCTOR	100 μ H
D519 \triangle	8-719-302-43	DIODE EL1Z		L003	1-414-856-11	INDUCTOR	10 μ H
D520	8-719-991-33	DIODE 1SS133T-77		L004	1-414-856-11	INDUCTOR	10 μ H
D521	8-719-921-63	DIODE MTZJ-7.5B		L301	1-414-857-11	INDUCTOR	100 μ H
D522	8-719-991-33	DIODE 1SS133T-77		L302	1-414-856-11	INDUCTOR	10 μ H
D523	8-719-109-69	DIODE MTZJ-T-77-3.6B		L351	1-414-186-31	INDUCTOR	33 μ H
D524	8-719-109-97	DIODE MTZJ-T-77-6.8B		L501	1-406-677-11	INDUCTOR	10mH
D530 \triangle	8-719-979-85	DIODE EGP20G		L502	1-412-552-11	INDUCTOR	2.2mH
D531	8-719-979-85	DIODE EGP20G		L503	1-406-677-11	INDUCTOR	10mH
D534	8-719-302-43	DIODE EL1Z		L504	1-406-677-11	INDUCTOR	10mH
D535	8-719-404-50	DIODE MA111-TX		L505	1-406-976-11	INDUCTOR	68 μ H
D536	1-216-295-91	SHORT		L511	1-411-189-11	INDUCTOR	15mH
D561	8-719-908-03	DIODE GP08D		L517	1-412-552-11	INDUCTOR	2.2mH
D1003	8-719-110-17	DIODE RD10ESB2		L1101	1-414-857-11	INDUCTOR	100 μ H
D1004	8-719-110-17	DIODE RD10ESB2		L1102	1-414-856-11	INDUCTOR	10 μ H
D1101	8-719-110-17	DIODE RD10ESB2		L1351	1-414-856-11	INDUCTOR	10 μ H
D1102	8-719-982-24	DIODE MTZJ-T-77-33A		L1352	1-412-756-21	INDUCTOR	56 μ H
D1103	8-719-109-89	DIODE RD5.6ESB2					
D1104	8-719-110-17	DIODE RD10ESB2					
D1301	8-719-404-50	DIODE MA111-TX					



COMPLETE PARTS LISTING

The components identified by shading and mark Δ are critical for safety. Replace only with part number specified.

Les composants identifiés par un trame et une marque Δ sont critiques pour la sécurité. Ne les remplacer que par une pièce portant le numéro spécifié.

REF.NO.	PART NO.	DESCRIPTION	REMARK	REF.NO.	PART NO.	DESCRIPTION	REMARK
TRANSISTOR				RESISTOR			
Q001	8-729-216-22	TRANSISTOR 2SA1162-G		R001	1-216-057-00	RES, CHIP 2.2K	5% 1/10W
Q002	8-729-422-27	TRANSISTOR 2SD601A-Q		R002	1-216-049-91	RES, CHIP 1K	5% 1/10W
Q003	8-729-422-27	TRANSISTOR 2SD601A-Q		R003	1-216-097-91	RES, CHIP 100K	5% 1/10W
Q004	8-729-216-22	TRANSISTOR 2SA1162-G		R004	1-216-121-91	RES, CHIP 1M	5% 1/10W
Q005	8-729-422-27	TRANSISTOR 2SD601A-Q		R006	1-247-815-91	CARBON 220	5% 1/4W
Q006	8-729-422-27	TRANSISTOR 2SD601A-Q		R007	1-216-073-00	RES, CHIP 10K	5% 1/10W
Q007	8-729-216-22	TRANSISTOR 2SA1162-G		R008	1-247-815-91	CARBON 220	5% 1/4W
Q010	8-729-422-27	TRANSISTOR 2SD601A-Q		R009	1-216-073-00	RES, CHIP 10K	5% 1/10W
Q011	8-729-422-27	TRANSISTOR 2SD601A-Q		R010	1-216-041-00	RES, CHIP 470	5% 1/10W
Q012	8-729-422-27	TRANSISTOR 2SD601A-Q		R011	1-216-065-91	RES, CHIP 4.7K	5% 1/10W
Q013	8-729-422-27	TRANSISTOR 2SD601A-Q		R012	1-216-033-00	RES, CHIP 220	5% 1/10W
Q014	8-729-422-27	TRANSISTOR 2SD601A-Q		R013	1-216-065-91	RES, CHIP 4.7K	5% 1/10W
Q015	8-729-422-27	TRANSISTOR 2SD601A-Q		R014	1-216-065-91	RES, CHIP 4.7K	5% 1/10W
Q016	8-729-422-27	TRANSISTOR 2SD601A-Q		R015	1-216-073-00	RES, CHIP 10K	5% 1/10W
Q017	8-729-216-22	TRANSISTOR 2SA1162-G		R016	1-216-073-00	RES, CHIP 10K	5% 1/10W
Q103	8-729-216-22	TRANSISTOR 2SA1162-G		R019	1-249-425-11	CARBON 4.7K	5% 1/4W
Q104	8-729-216-22	TRANSISTOR 2SA1162-G		R020	1-216-065-91	RES, CHIP 4.7K	5% 1/10W
Q301	8-729-422-27	TRANSISTOR 2SD601A-Q		R022	1-249-429-11	CARBON 10K	5% 1/4W
Q303	8-729-422-27	TRANSISTOR 2SD601A-Q		R023	1-216-089-91	RES, CHIP 47K	5% 1/10W
Q304	8-729-216-22	TRANSISTOR 2SA1162-G		R025	1-216-033-00	RES, CHIP 220	5% 1/10W
Q305	8-729-216-22	TRANSISTOR 2SA1162-G		R026	1-216-121-91	RES, CHIP 1M	5% 1/10W
Q306	8-729-216-22	TRANSISTOR 2SA1162-G		R027	1-216-049-91	RES, CHIP 1K	5% 1/10W
Q307	8-729-422-27	TRANSISTOR 2SD601A-Q		R028	1-249-429-11	CARBON 10K	5% 1/4W
Q310	8-729-216-22	TRANSISTOR 2SA1162-G		R029	1-216-025-91	RES, CHIP 100	5% 1/10W
Q311	8-729-216-22	TRANSISTOR 2SA1162-G		R030	1-249-425-11	CARBON 4.7K	5% 1/4W
Q313	8-729-422-27	TRANSISTOR 2SD601A-Q		R031	1-247-815-91	CARBON 220	5% 1/4W
Q314	8-729-422-27	TRANSISTOR 2SD601A-Q		R032	1-216-033-00	RES, CHIP 220	5% 1/10W
Q351	8-729-422-27	TRANSISTOR 2SD601A-Q		R036	1-216-049-91	RES, CHIP 1K	5% 1/10W
Q352	8-729-422-27	TRANSISTOR 2SD601A-Q		R037	1-216-049-91	RES, CHIP 1K	5% 1/10W
Q359	8-729-216-22	TRANSISTOR 2SA1162-G		R038	1-216-049-91	RES, CHIP 1K	5% 1/10W
Q361	8-729-422-27	TRANSISTOR 2SD601A-Q		R039	1-247-807-31	CARBON 100	5% 1/4W
Q362	8-729-422-27	TRANSISTOR 2SD601A-Q		R040	1-247-815-91	CARBON 220	5% 1/4W
Q364	8-729-216-22	TRANSISTOR 2SA1162-G		R041	1-216-065-91	RES, CHIP 4.7K	5% 1/10W
Q369	8-729-422-27	TRANSISTOR 2SD601A-Q		R042	1-216-065-91	RES, CHIP 4.7K	5% 1/10W
Q370	8-729-422-27	TRANSISTOR 2SD601A-Q		R043	1-216-033-00	RES, CHIP 220	5% 1/10W
Q501	8-729-140-50	TRANSISTOR 2SC3209LK		R044	1-216-049-91	RES, CHIP 1K	5% 1/10W
Q502 Δ	8-729-045-26	TRANSISTOR 2SD2580-CA		R045	1-247-815-91	CARBON 220	5% 1/4W
Q503	8-729-422-27	TRANSISTOR 2SD601A-Q		R046	1-247-815-91	CARBON 220	5% 1/4W
Q504	8-729-422-27	TRANSISTOR 2SD601A-Q		R047	1-249-417-11	CARBON 1K	5% 1/4W
Q507	8-729-043-95	TRANSISTOR 2SC3840(3)		R048	1-249-417-11	CARBON 1K	5% 1/4W
Q511 Δ	8-729-422-27	TRANSISTOR 2SD601A-Q		R049	1-249-417-11	CARBON 1K	5% 1/4W
Q512 Δ	8-729-809-29	TRANSISTOR 2SC4159-E		R050	1-247-815-91	CARBON 220	5% 1/4W
Q561	8-729-422-27	TRANSISTOR 2SD601A-Q		R051	1-247-815-91	CARBON 220	5% 1/4W
Q562	8-729-422-27	TRANSISTOR 2SD601A-Q		R052	1-216-065-91	RES, CHIP 4.7K	5% 1/10W
Q1102	8-729-119-78	TRANSISTOR 2SC2785-HFE		R053	1-216-065-91	RES, CHIP 4.7K	5% 1/10W
Q1103	8-729-422-27	TRANSISTOR 2SD601A-Q		R054	1-216-065-91	RES, CHIP 4.7K	5% 1/10W
Q1301	8-729-216-22	TRANSISTOR 2SA1162-G		R055	1-216-097-91	RES, CHIP 100K	5% 1/10W
Q1302	8-729-422-27	TRANSISTOR 2SD601A-Q		R056	1-216-033-00	RES, CHIP 220	5% 1/10W
Q1303	8-729-422-27	TRANSISTOR 2SD601A-Q		R057	1-249-417-11	CARBON 1K	5% 1/4W
Q1352	8-729-422-27	TRANSISTOR 2SD601A-Q		R058	1-216-041-00	RES, CHIP 470	5% 1/10W
Q1353	8-729-216-22	TRANSISTOR 2SA1162-G		R060	1-216-073-00	RES, CHIP 10K	5% 1/10W
Q1354	8-729-422-27	TRANSISTOR 2SD601A-Q		R061	1-216-073-00	RES, CHIP 10K	5% 1/10W

The components identified by shading and mark \triangle are critical for safety. Replace only with part number specified.

Les composants identifiés par un trame et une marque \triangle sont critiques pour la sécurité. Ne les remplacer que par une pièce portant le numéro spécifié.

COMPLETE PARTS LISTING

A

REF.NO.	PART NO.	DESCRIPTION	REMARK	REF.NO.	PART NO.	DESCRIPTION	REMARK
R062	1-216-073-00	RES, CHIP	10K 5% 1/10W	R321	1-216-057-00	RES, CHIP	2.2K 5% 1/10W
R063	1-216-073-00	RES, CHIP	10K 5% 1/10W	R324	1-216-073-00	RES, CHIP	10K 5% 1/10W
R064	1-247-815-91	CARBON	220 5% 1/4W	R325	1-216-033-00	RES, CHIP	220 5% 1/10W
R065	1-247-815-91	CARBON	220 5% 1/4W	R326	1-216-085-00	RES, CHIP	33K 5% 1/10W
R066	1-247-815-91	CARBON	220 5% 1/4W	R327	1-216-033-00	RES, CHIP	220 5% 1/10W
R067	1-249-413-11	CARBON	470 5% 1/4W	R330	1-208-806-11	RES, CHIP	10K 0.50% 1/10W
R068	1-247-815-91	CARBON	220 5% 1/4W	R331	1-216-065-91	RES, CHIP	4.7K 5% 1/10W
R069	1-247-815-91	CARBON	220 5% 1/4W	R332	1-216-033-00	RES, CHIP	220 5% 1/10W
R070	1-249-421-11	CARBON	2.2K 5% 1/4W	R334	1-216-033-00	RES, CHIP	220 5% 1/10W
R071	1-247-815-91	CARBON	220 5% 1/4W	R335	1-216-033-00	RES, CHIP	220 5% 1/10W
R072	1-216-033-00	RES, CHIP	220 5% 1/10W	R336	1-216-049-91	RES, CHIP	1K 5% 1/10W
R073	1-216-033-00	RES, CHIP	220 5% 1/10W	R337	1-216-347-11	METAL OXIDE	0.68 5% 1W F
R074	1-216-033-00	RES, CHIP	220 5% 1/10W	R340	1-216-105-91	RES, CHIP	220K 5% 1/10W
R075	1-216-033-00	RES, CHIP	220 5% 1/10W	R341	1-216-073-00	RES, CHIP	10K 5% 1/10W
R076	1-216-033-00	RES, CHIP	220 5% 1/10W	R342	1-216-097-91	RES, CHIP	100K 5% 1/10W
R077	1-216-033-00	RES, CHIP	220 5% 1/10W	R343	1-216-093-91	RES, CHIP	68K 5% 1/10W
R078	1-249-417-11	CARBON	1K 5% 1/4W	R344	1-216-073-00	RES, CHIP	10K 5% 1/10W
R079	1-216-033-00	RES, CHIP	220 5% 1/10W	R346	1-216-023-00	RES, CHIP	82 5% 1/10W
R080	1-216-065-91	RES, CHIP	4.7K 5% 1/10W	R347	1-216-041-00	RES, CHIP	470 5% 1/10W
R081	1-216-025-91	RES, CHIP	100 5% 1/10W	R348	1-216-033-00	RES, CHIP	220 5% 1/10W
R082	1-216-025-91	RES, CHIP	100 5% 1/10W	R349	1-216-041-00	RES, CHIP	470 5% 1/10W
R083	1-249-429-11	CARBON	10K 5% 1/4W	R350	1-247-807-31	CARBON	100 5% 1/4W
R084	1-216-049-91	RES, CHIP	1K 5% 1/10W	R352	1-208-803-11	RES, CHIP	7.5K 0.50% 1/10W
R085	1-216-065-91	RES, CHIP	4.7K 5% 1/10W	R353	1-216-295-91	SHORT	
R086	1-216-073-00	RES, CHIP	10K 5% 1/10W	R354	1-216-073-00	RES, CHIP	10K 5% 1/10W
R087	1-247-815-91	CARBON	220 5% 1/4W	R355	1-216-069-00	RES, CHIP	6.8K 5% 1/10W
R089	1-216-073-00	RES, CHIP	10K 5% 1/10W	R356	1-216-025-91	RES, CHIP	100 5% 1/10W
R090	1-216-033-00	RES, CHIP	220 5% 1/10W	R358	1-216-295-91	SHORT	
R092	1-249-429-11	CARBON	10K 5% 1/4W	R359	1-216-073-00	RES, CHIP	10K 5% 1/10W
R093	1-216-065-91	RES, CHIP	4.7K 5% 1/10W	R360	1-247-815-91	CARBON	220 5% 1/4W
R096	1-216-033-00	RES, CHIP	220 5% 1/10W	R361	1-216-049-91	RES, CHIP	1K 5% 1/10W
R097	1-216-065-91	RES, CHIP	4.7K 5% 1/10W	R362	1-216-073-00	RES, CHIP	10K 5% 1/10W
R099	1-216-065-91	RES, CHIP	4.7K 5% 1/10W	R370	1-216-049-91	RES, CHIP	1K 5% 1/10W
R106	1-216-081-00	RES, CHIP	22K 5% 1/10W	R372	1-216-097-91	RES, CHIP	100K 5% 1/10W
R107	1-216-081-00	RES, CHIP	22K 5% 1/10W	R373	1-216-121-91	RES, CHIP	1M 5% 1/10W
R108	1-216-081-00	RES, CHIP	22K 5% 1/10W	R374	1-216-041-00	RES, CHIP	470 5% 1/10W
R109	1-216-081-00	RES, CHIP	22K 5% 1/10W	R375	1-216-049-91	RES, CHIP	1K 5% 1/10W
R131	1-216-037-00	RES, CHIP	330 5% 1/10W	R376	1-216-025-91	RES, CHIP	100 5% 1/10W
R132	1-216-113-00	RES, CHIP	470K 5% 1/10W	R378	1-216-083-00	RES, CHIP	27K 5% 1/10W
R133	1-216-037-00	RES, CHIP	330 5% 1/10W	R383	1-216-025-91	RES, CHIP	100 5% 1/10W
R135	1-216-073-00	RES, CHIP	10K 5% 1/10W	R384	1-216-037-00	RES, CHIP	330 5% 1/10W
R136	1-216-073-00	RES, CHIP	10K 5% 1/10W	R385	1-249-425-11	CARBON	4.7K 5% 1/4W
R137	1-216-049-91	RES, CHIP	1K 5% 1/10W	R386	1-216-073-00	RES, CHIP	10K 5% 1/10W
R304	1-216-033-00	RES, CHIP	220 5% 1/10W	R387	1-216-037-00	RES, CHIP	330 5% 1/10W
R305	1-247-815-91	CARBON	220 5% 1/4W	R398	1-216-095-00	RES, CHIP	82K 5% 1/10W
R306	1-247-815-91	CARBON	220 5% 1/4W	R501	1-216-041-00	RES, CHIP	470 5% 1/10W
R307	1-216-295-91	SHORT		R502	1-216-065-91	RES, CHIP	4.7K 5% 1/10W
R309	1-216-295-91	SHORT		R503	1-249-425-11	CARBON	4.7K 5% 1/4W F
R311	1-216-073-00	RES, CHIP	10K 5% 1/10W	R504	1-216-455-21	METAL OXIDE	560 5% 2W F
R313	1-216-065-91	RES, CHIP	4.7K 5% 1/10W	R505	1-247-863-91	CARBON	22K 5% 1/4W
R314	1-216-073-00	RES, CHIP	10K 5% 1/10W	R506	1-215-861-00	METAL OXIDE	47 5% 1W F
R315	1-216-073-00	RES, CHIP	10K 5% 1/10W	R507	1-249-401-11	CARBON	47 5% 1/4W
R316	1-216-073-00	RES, CHIP	10K 5% 1/10W	R508	1-249-425-11	CARBON	4.7K 5% 1/4W
R319	1-216-057-00	RES, CHIP	2.2K 5% 1/10W	R509	1-260-328-11	CARBON	1K 5% 1/2W
R320	1-216-057-00	RES, CHIP	2.2K 5% 1/10W	R510 \triangle	1-215-860-11	METAL OXIDE	33 5% 1W F



COMPLETE PARTS LISTING

The components identified by shading and mark **△** are critical for safety. Replace only with part number specified.

The components identified by **☒** in this manual have been carefully factory-selected for each set in order to satisfy regulations regarding X-ray radiation. Should replacement be required, replace only with the value originally used.

REF.NO.	PART NO.	DESCRIPTION	REMARK
R512	1-215-910-00	METAL OXIDE	68 5% 3W F
R514	1-216-081-00	RES, CHIP	22K 5% 1/10W
R515	1-208-812-11	RES, CHIP	18K 0.50% 1/10W
R516	1-208-790-11	RES, CHIP	2.2K 0.50% 1/10W
R517	1-249-417-11	CARBON	1K 5% 1/4W
R518	1-216-073-00	RES, CHIP	10K 5% 1/10W
R519	1-249-413-11	CARBON	470 5% 1/4W
R520	1-215-907-11	METAL OXIDE	22 5% 3W F
R521	1-216-081-00	RES, CHIP	22K 5% 1/10W
R523	1-208-808-11	RES, CHIP	12K 0.50% 1/10W
R524	1-249-429-11	CARBON	10K 5% 1/4W
R525	1-208-804-11	RES, CHIP	8.2K 0.50% 1/10W
R526	1-215-880-00	METAL OXIDE	10 5% 2W F
R527	1-216-097-91	RES, CHIP	100K 5% 1/10W
R528	1-208-814-91	RES, CHIP	22K 0.50% 1/10W
R529	1-208-814-91	RES, CHIP	22K 0.50% 1/10W
☒ R530△	1-208-808-11	RES, CHIP	12K 0.50% 1/10W
☒ R531△	1-216-091-00	RES, CHIP	56K 5% 1/10W
R532	1-208-760-11	RES, CHIP	120 0.50% 1/10W
R533	1-215-902-11	METAL OXIDE	47K 5% 1W F
R536△	1-260-288-11	CARBON	0.47 5% 1/2W
R537△	1-260-288-11	CARBON	0.47 5% 1/2W
R538	1-247-887-00	CARBON	220K 5% 1/4W
R539	1-215-891-11	METAL OXIDE	680 5% 2W F
R540	1-216-093-91	RES, CHIP	68K 5% 1/10W
R541	1-215-922-11	METAL OXIDE	6.8K 5% 3W F
R542	1-215-921-11	METAL OXIDE	4.7K 5% 3W F
R543△	1-249-377-11	CARBON	0.47 5% 1/4W F
R544	1-216-113-00	RES, CHIP	470K 5% 1/10W
R545△	1-249-387-11	CARBON	3.3 5% 1/4W F
R546	1-215-453-00	METAL	22K 1% 1/4W
R547	1-215-457-00	METAL	33K 1% 1/4W
R548	1-215-921-11	METAL OXIDE	4.7K 5% 3W F
R549	1-215-437-00	METAL	4.7K 1% 1/4W
R550△	1-249-377-11	CARBON	0.47 5% 1/4W F
R551	1-215-873-00	METAL OXIDE	4.7K 5% 1W F
R552	1-216-455-21	METAL OXIDE	560 5% 2W F
R553△	1-249-377-11	CARBON	0.47 5% 1/4W F
R554	1-215-894-11	METAL OXIDE	2.2K 5% 2W F
R555	1-249-441-11	CARBON	100K 5% 1/4W
R556	1-249-441-11	CARBON	100K 5% 1/4W
R557	1-249-441-11	CARBON	100K 5% 1/4W
R559	1-216-017-91	RES, CHIP	47 5% 1/10W
R560	1-215-922-11	METAL OXIDE	6.8K 5% 3W F
R561	1-208-806-11	RES, CHIP	10K 0.50% 1/10W
R563	1-214-798-21	METAL	1.8 1% 1/2W
R565	1-215-889-00	METAL OXIDE	330 5% 2W F
R566	1-216-069-00	RES, CHIP	6.8K 5% 1/10W
R567△	1-249-385-11	CARBON	2.2 5% 1/4W F
R568	1-216-069-00	RES, CHIP	6.8K 5% 1/10W
R569	1-208-806-11	RES, CHIP	10K 0.50% 1/10W
R570	1-216-097-91	RES, CHIP	100K 5% 1/10W

REF.NO.	PART NO.	DESCRIPTION	REMARK
R571	1-216-081-00	RES, CHIP	22K 5% 1/10W
R572	1-216-081-00	RES, CHIP	22K 5% 1/10W
R573	1-216-097-91	RES, CHIP	100K 5% 1/10W
R574	1-214-798-21	METAL	1.8 1% 1/2W
R576	1-215-905-11	METAL OXIDE	10 5% 3W F
R577	1-216-049-91	RES, CHIP	1K 5% 1/10W
R578	1-216-057-00	RES, CHIP	2.2K 5% 1/10W
R580	1-249-441-11	CARBON	100K 5% 1/4W
R581	1-247-887-00	CARBON	220K 5% 1/4W
R582	1-249-421-11	CARBON	2.2K 5% 1/4W
R1001	1-247-807-31	CARBON	100 5% 1/4W
R1002	1-247-807-31	CARBON	100 5% 1/4W
R1003	1-216-073-00	RES, CHIP	10K 5% 1/10W
R1005	1-216-073-00	RES, CHIP	10K 5% 1/10W
R1006	1-216-025-91	RES, CHIP	100 5% 1/10W
R1007	1-216-025-91	RES, CHIP	100 5% 1/10W
R1011	1-249-387-11	CARBON	3.3 5% 1/4W F
R1012	1-216-049-91	RES, CHIP	1K 5% 1/10W
R1030	1-216-065-91	RES, CHIP	4.7K 5% 1/10W
R1031	1-216-065-91	RES, CHIP	4.7K 5% 1/10W
R1101	1-216-049-91	RES, CHIP	1K 5% 1/10W
R1102	1-215-900-11	METAL OXIDE	22K 5% 2W F
R1103	1-216-049-91	RES, CHIP	1K 5% 1/10W
R1104	1-216-083-00	RES, CHIP	27K 5% 1/10W
R1105	1-216-689-11	RES, CHIP	39K 5% 1/10W
R1106	1-216-049-91	RES, CHIP	1K 5% 1/10W
R1107	1-216-065-91	RES, CHIP	4.7K 5% 1/10W
R1108	1-216-073-00	RES, CHIP	10K 5% 1/10W
R1109	1-216-017-91	RES, CHIP	47 5% 1/10W
R1110	1-216-017-91	RES, CHIP	47 5% 1/10W
R1111	1-216-017-91	RES, CHIP	47 5% 1/10W
R1113	1-249-417-11	CARBON	1K 5% 1/4W
R1114	1-249-417-11	CARBON	1K 5% 1/4W
R1115	1-216-041-00	RES, CHIP	470 5% 1/10W
R1117	1-249-425-11	CARBON	4.7K 5% 1/4W
R1118	1-249-425-11	CARBON	4.7K 5% 1/4W
R1120	1-216-059-00	RES, CHIP	2.7K 5% 1/10W
R1121	1-216-037-00	RES, CHIP	330 5% 1/10W
R1122	1-216-113-00	RES, CHIP	470K 5% 1/10W
R1123	1-216-037-00	RES, CHIP	330 5% 1/10W
R1125	1-216-059-00	RES, CHIP	2.7K 5% 1/10W
R1126	1-216-037-00	RES, CHIP	330 5% 1/10W
R1127	1-216-113-00	RES, CHIP	470K 5% 1/10W
R1128	1-216-037-00	RES, CHIP	330 5% 1/10W
R1129	1-216-295-91	SHORT	
R1130	1-216-059-00	RES, CHIP	2.7K 5% 1/10W
R1301	1-249-401-11	CARBON	47 5% 1/4W
R1302	1-249-401-11	CARBON	47 5% 1/4W
R1303	1-216-065-91	RES, CHIP	4.7K 5% 1/10W
R1304	1-216-051-00	RES, CHIP	1.2K 5% 1/10W
R1305	1-216-051-00	RES, CHIP	1.2K 5% 1/10W
R1306	1-216-049-91	RES, CHIP	1K 5% 1/10W
R1313	1-216-295-91	SHORT	
R1314	1-216-049-91	RES, CHIP	1K 5% 1/10W
R1315	1-216-025-91	RES, CHIP	100 5% 1/10W

The components identified by shading and mark \triangle are critical for safety. Replace only with part number specified.

Les composants identifiés par un trame et une marque \triangle sont critiques pour la sécurité. Ne les remplacer que par une pièce portant le numéro spécifié.

COMPLETE PARTS LISTING

A

REF.NO.	PART NO.	DESCRIPTION	REMARK	REF.NO.	PART NO.	DESCRIPTION	REMARK
R1316	1-216-091-00	RES, CHIP	56K 5% 1/10W	TUNER			
R1317	1-216-105-91	RES, CHIP	220K 5% 1/10W	TU102 \triangle 8-598-431-00 TUNER, FSS BTF-WA411			
R1318	1-216-065-91	RES, CHIP	4.7K 5% 1/10W	(KV-32FS10/32FV15/32XBR250/34FV10/34FV15/34FV15C/34FX250C/ 36FS10/36FV15/36XBR250/38FX250/38FX250C only)			
R1319	1-260-290-71	CARBON	0.68 5% 1/2W	TU102 \triangle 8-598-475-00 TUNER, FSS BTF-WL411			
R1320	1-216-073-00	RES, CHIP	10K 5% 1/10W	(KV-34FV15K/38FV15K only)			
R1321	1-216-065-91	RES, CHIP	4.7K 5% 1/10W	TU102 \triangle 8-598-477-00 TUNER, FSS BTF-WG411			
R1322	1-216-047-91	RES, CHIP	820 5% 1/10W	(KV-34FV15T/38FX250T only)			
R1323	1-216-049-91	RES, CHIP	1K 5% 1/10W	CRYSTAL			
R1324	1-216-295-91	SHORT		X001	1-578-774-11	VIBRATOR, CRYSTAL	
R1325	1-216-057-00	RES, CHIP	2.2K 5% 1/10W	X302	1-567-505-11	OSCILLATOR, CRYSTAL	
R1330	1-216-065-91	RES, CHIP	4.7K 5% 1/10W				
R1333	1-216-065-91	RES, CHIP	4.7K 5% 1/10W				
R1337	1-216-049-91	RES, CHIP	1K 5% 1/10W				
R1358	1-216-025-91	RES, CHIP	100 5% 1/10W				
R1359	1-216-025-91	RES, CHIP	100 5% 1/10W				
R1360	1-216-049-91	RES, CHIP	1K 5% 1/10W				
R1361	1-216-049-91	RES, CHIP	1K 5% 1/10W				
R1362	1-216-113-00	RES, CHIP	470K 5% 1/10W				
R1363	1-216-057-00	RES, CHIP	2.2K 5% 1/10W				
R1364	1-216-097-91	RES, CHIP	100K 5% 1/10W				
R1365	1-216-089-91	RES, CHIP	47K 5% 1/10W				
R1366	1-216-107-00	RES, CHIP	270K 5% 1/10W				
R1369	1-216-093-91	RES, CHIP	68K 5% 1/10W				
R1371	1-216-295-91	SHORT					
R1373	1-216-025-91	RES, CHIP	100 5% 1/10W				
R1374	1-216-089-91	RES, CHIP	47K 5% 1/10W				
R1385	1-216-049-91	RES, CHIP	1K 5% 1/10W				
R1387	1-249-429-11	CARBON	10K 5% 1/4W				
R1389	1-216-025-91	RES, CHIP	100 5% 1/10W				
R1390	1-249-417-11	CARBON	1K 5% 1/4W				
R1391	1-216-081-00	RES, CHIP	22K 5% 1/10W				
R1392	1-216-081-00	RES, CHIP	22K 5% 1/10W				
R1395	1-216-055-00	RES, CHIP	1.8K 5% 1/10W				
R1397	1-216-025-91	RES, CHIP	100 5% 1/10W				
R1398	1-216-033-00	RES, CHIP	220 5% 1/10W				
SWITCH							
S501	1-572-707-11	SWITCH, LEVER					
S502	1-572-707-11	SWITCH, LEVER					
TRANSFORMER							
T501	1-437-195-11	TRANSFORMER, HORIZONTAL DRIVE					
T502 \triangle	1-426-981-11	TRANSFORMER, FERRITE (PMT)					
T503 \triangle	1-453-286-11	FBT ASSY, NX-4600//X4C4					
T504 \triangle	1-424-584-11	TRANSFORMER, DYNAMIC FOCUS					
T505 \triangle	1-419-192-11	COIL, HORIZONTAL LINEARITY					
THERMISTOR							
TH501	1-800-193-00	THERMISTOR					



COMMON PARTS LISTING

REF.NO.	PART NO.	DESCRIPTION	REMARK
---------	----------	-------------	--------



* A-1298-956-A AK BOARD, COMPLETE
(KV-32FS10/34FV10/36FS10 only)

* A-1298-957-A AK BOARD, COMPLETE
(KV-32FV15/34FV15/34FV15C/34FV15K/34FV15T/ 36FV15/38FV15K only)

* A-1298-980-A AK BOARD, COMPLETE
(KV-32XBR250/34FX250C/36XBR250/38FX250/38FX250C/38FX250T only)

4-382-854-11 SCREW (M3X10), P, SW (+)

CAPACITOR

C101		VARIANT (SEE VARIANT PARTS LIST)		
C102		VARIANT (SEE VARIANT PARTS LIST)		
C104		VARIANT (SEE VARIANT PARTS LIST)		
C106		VARIANT (SEE VARIANT PARTS LIST)		
C108		VARIANT (SEE VARIANT PARTS LIST)		
C109		VARIANT (SEE VARIANT PARTS LIST)		
C110		VARIANT (SEE VARIANT PARTS LIST)		
C111		VARIANT (SEE VARIANT PARTS LIST)		
C113		VARIANT (SEE VARIANT PARTS LIST)		
C115		VARIANT (SEE VARIANT PARTS LIST)		
C175	1-126-941-11	ELECT	470µF	20% 25V
C440	1-126-965-11	ELECT	22µF	20% 50V
C441	1-165-319-11	CERAMIC CHIP	0.1µF	50V
C442	1-126-960-11	ELECT	1µF	20% 50V
C443	1-165-319-11	CERAMIC CHIP	0.1µF	50V
C444	1-164-346-11	CERAMIC CHIP	1µF	16V
C445	1-165-319-11	CERAMIC CHIP	0.1µF	50V
C446	1-164-346-11	CERAMIC CHIP	1µF	16V
C447	1-107-823-11	CERAMIC CHIP	0.47µF	10% 16V
C448	1-163-017-00	CERAMIC CHIP	0.0047µF	10% 50V
C449	1-107-823-11	CERAMIC CHIP	0.47µF	10% 16V
C453	1-163-017-00	CERAMIC CHIP	0.0047µF	10% 50V
C454	1-163-133-00	CERAMIC CHIP	470pF	5% 50V
C455	1-165-319-11	CERAMIC CHIP	0.1µF	50V
C456	1-163-023-00	CERAMIC CHIP	0.015µF	10% 50V
C457	1-164-161-11	CERAMIC CHIP	0.0022µF	10% 50V
C1401	1-126-963-11	ELECT	4.7µF	20% 50V
C1402	1-126-968-11	ELECT	100µF	20% 50V
C1403	1-126-963-11	ELECT	4.7µF	20% 50V
C1404	1-126-960-11	ELECT	1µF	20% 50V
C1405	1-126-960-11	ELECT	1µF	20% 50V
C1406	1-164-004-11	CERAMIC CHIP	0.1µF	10% 25V
C1407	1-163-989-11	CERAMIC CHIP	0.033µF	10% 25V
C1408	1-163-989-11	CERAMIC CHIP	0.033µF	10% 25V
C1409	1-164-182-11	CERAMIC CHIP	0.0033µF	10% 50V
C1410	1-163-018-00	CERAMIC CHIP	0.0056µF	10% 50V
C1411	1-164-182-11	CERAMIC CHIP	0.0033µF	10% 50V
C1412	1-163-037-11	CERAMIC CHIP	0.022µF	10% 50V
C1413	1-163-009-11	CERAMIC CHIP	0.001µF	10% 50V
C1414	1-163-009-11	CERAMIC CHIP	0.001µF	10% 50V

REF.NO.	PART NO.	DESCRIPTION	REMARK
---------	----------	-------------	--------

C1415	1-126-963-11	ELECT	4.7µF	20% 50V
C1416	1-126-963-11	ELECT	4.7µF	20% 50V
C1417	1-126-963-11	ELECT	4.7µF	20% 50V
C1420	1-163-037-11	CERAMIC CHIP	0.022µF	10% 50V
C1421	1-126-963-11	ELECT	4.7µF	20% 50V
C1422	1-164-004-11	CERAMIC CHIP	0.1µF	10% 25V
C1423	1-126-941-11	ELECT	470µF	20% 25V
C1428	1-126-963-11	ELECT	4.7µF	20% 50V
C1429	1-126-963-11	ELECT	4.7µF	20% 50V
C1450	1-126-963-11	ELECT	4.7µF	20% 50V
C1451	1-126-963-11	ELECT	4.7µF	20% 50V
C1452	1-163-986-00	CERAMIC CHIP	0.027µF	10% 25V
C1461	1-126-960-11	ELECT	1µF	20% 50V
C1462	1-126-960-11	ELECT	1µF	20% 50V
C1464	1-163-038-91	CERAMIC CHIP	0.1µF	25V
C1465	1-126-960-11	ELECT	1µF	20% 50V
C1467	1-104-666-11	ELECT	220µF	20% 25V
C1468	1-126-960-11	ELECT	1µF	20% 50V
C1470	1-126-960-11	ELECT	1µF	20% 50V
C1471	1-136-165-00	FILM	0.1µF	5% 50V
C1472	1-137-194-81	FILM	0.47µF	5% 50V
C1473	1-128-550-11	ELECT	2200µF	20% 50V
C1474	1-136-165-00	FILM	0.1µF	5% 50V
C1475	1-128-550-11	ELECT	2200µF	20% 50V
C1476	1-128-550-11	ELECT	2200µF	20% 50V
C1477	1-126-971-11	ELECT	470µF	20% 50V
C1478	1-126-971-11	ELECT	470µF	20% 50V
C1904		VARIANT (SEE VARIANT PARTS LIST)		
C1905		VARIANT (SEE VARIANT PARTS LIST)		
C1906		VARIANT (SEE VARIANT PARTS LIST)		
C1907		VARIANT (SEE VARIANT PARTS LIST)		
C1908		VARIANT (SEE VARIANT PARTS LIST)		
C1909		VARIANT (SEE VARIANT PARTS LIST)		
C1910		VARIANT (SEE VARIANT PARTS LIST)		
C1911		VARIANT (SEE VARIANT PARTS LIST)		
C1912		VARIANT (SEE VARIANT PARTS LIST)		

CONNECTOR

CN1462*	1-564-507-11	PLUG, CONNECTOR 4P		
CN1463*	1-564-509-11	PLUG, CONNECTOR 6P		
CN1464*	1-564-513-11	PLUG, CONNECTOR 10P		
CN1465*		VARIANT (SEE VARIANT PARTS LIST)		
CN1466*	1-564-515-11	PLUG, CONNECTOR 12P		
CN1467*		VARIANT (SEE VARIANT PARTS LIST)		
CN1468		VARIANT (SEE VARIANT PARTS LIST)		

DIODE

D101		VARIANT (SEE VARIANT PARTS LIST)		
D103		VARIANT (SEE VARIANT PARTS LIST)		
D104		VARIANT (SEE VARIANT PARTS LIST)		
D105		VARIANT (SEE VARIANT PARTS LIST)		
D106		VARIANT (SEE VARIANT PARTS LIST)		



COMMON PARTS LISTING

<u>REF.NO.</u>	<u>PART NO.</u>	<u>DESCRIPTION</u>	<u>REMARK</u>	<u>REF.NO.</u>	<u>PART NO.</u>	<u>DESCRIPTION</u>	<u>REMARK</u>
R1487		VARIANT (SEE VARIANT PARTS LIST)					
R1902		VARIANT (SEE VARIANT PARTS LIST)					
R1904		VARIANT (SEE VARIANT PARTS LIST)					
R1906		VARIANT (SEE VARIANT PARTS LIST)					
R1907		VARIANT (SEE VARIANT PARTS LIST)					
R2904		VARIANT (SEE VARIANT PARTS LIST)					
R2905		VARIANT (SEE VARIANT PARTS LIST)					
R2909		VARIANT (SEE VARIANT PARTS LIST)					
R2910		VARIANT (SEE VARIANT PARTS LIST)					
R2912		VARIANT (SEE VARIANT PARTS LIST)					
R2913		VARIANT (SEE VARIANT PARTS LIST)					
R2914		VARIANT (SEE VARIANT PARTS LIST)					
R2915		VARIANT (SEE VARIANT PARTS LIST)					
R2916		VARIANT (SEE VARIANT PARTS LIST)					

TUNER

TU101		VARIANT (SEE VARIANT PARTS LIST)					
-------	--	----------------------------------	--	--	--	--	--

The components identified by shading and mark \triangle are critical for safety. Replace only with part number specified.

Les composants identifiés per un trame et une marque \triangle sont critiques pour la securite. Ne les remplacer que par une piece portant le numero specifie.

AK BOARD VARIANT PARTS LIST

The parts on this page belong to the following model(s) only:
KV-32FV15/34FV15/34FV15C/34FV15K/34FV15T/36FV15/38FV15K

REF.NO.	PART NO.	DESCRIPTION	REMARK
AK BOARD VARIANT PARTS LIST: KV-32FV15/34FV15/34FV15C/34FV15K/34FV15T/ 36FV15/38FV15K			
CAPACITOR			
C101	1-126-960-11	ELECT	1 μ F 20% 50V
C102	1-164-161-11	CERAMIC	0.0022 μ F 10% 50V
C104	1-126-964-11	ELECT	10 μ F 20% 50V
C106	1-104-664-11	ELECT	47 μ F 20% 25V
C108	1-126-942-61	ELECT	1000 μ F 20% 25V
C109	1-163-259-91	CERAMIC	220pF 5% 50V
C110	1-163-809-11	CERAMIC	0.047 μ F 10% 25V
C111	1-126-960-11	ELECT	1 μ F 20% 50V
C113	1-104-666-11	ELECT	220 μ F 20% 25V
C115	1-126-960-11	ELECT	1 μ F 20% 50V
C1904	1-102-129-00	CERAMIC	0.01 μ F 10% 50V
C1905	1-126-964-11	ELECT	10 μ F 20% 50V
C1906	1-102-129-00	CERAMIC	0.01 μ F 10% 50V
C1907	1-126-964-11	ELECT	10 μ F 20% 50V
C1908	1-163-009-11	CERAMIC	0.001 μ F 10% 50V
C1909	1-163-009-11	CERAMIC	0.001 μ F 10% 50V
C1910	1-163-009-11	CERAMIC	0.001 μ F 10% 50V
C1911	1-163-009-11	CERAMIC	0.001 μ F 10% 50V
C1912	1-163-009-11	CERAMIC	0.001 μ F 10% 50V
CONNECTOR			
CN1467*	1-564-510-11	PLUG, CONNECTOR 7P	
CN1468	1-695-915-11	TAB (CONTACT)	
DIODE			
D101	8-719-109-89	DIODE RD5.6ESB2	
D103	8-719-991-33	DIODE 1SS133T-77	
D104	8-719-991-33	DIODE 1SS133T-77	
D105	8-719-991-33	DIODE 1SS133T-77	
D106	8-719-991-33	DIODE 1SS133T-77	
D107	8-719-991-33	DIODE 1SS133T-77	
D108	8-719-110-17	DIODE RD10ESB2	
D109	8-719-110-17	DIODE RD10ESB2	
IC			
IC1901	8-752-058-68	IC CXA1315M	
IC1902	8-759-470-63	IC NJM2145M-TE2	
COIL			
L102	1-414-856-11	INDUCTOR	10 μ H
L105	1-414-857-11	INDUCTOR	100 μ H

REF.NO.	PART NO.	DESCRIPTION	REMARK
TRANSISTOR			
Q101	8-729-119-78	TRANSISTOR	2SC2785-HFE
Q105	8-729-216-22	TRANSISTOR	2SA1162-G
Q106	8-729-422-27	TRANSISTOR	2SD601A-Q
Q1902	8-729-216-22	TRANSISTOR	2SA1162-G
Q1903	8-729-216-22	TRANSISTOR	2SA1162-G
Q1918	8-729-216-22	TRANSISTOR	2SA1162-G
RESISTOR			
R101	1-216-065-91	RES, CHIP	4.7K 5% 1/10W
R102	1-216-083-00	RES, CHIP	27K 5% 1/10W
R103	1-216-689-11	RES, CHIP	39K 5% 1/10W
R104	1-216-049-91	RES, CHIP	1K 5% 1/10W
R112	1-216-057-00	RES, CHIP	2.2K 5% 1/10W
R113	1-216-097-91	RES, CHIP	100K 5% 1/10W
R114	1-216-121-91	RES, CHIP	1M 5% 1/10W
R115	1-216-073-00	RES, CHIP	10K 5% 1/10W
R116	1-216-073-00	RES, CHIP	10K 5% 1/10W
R117	1-216-065-91	RES, CHIP	4.7K 5% 1/10W
R118	1-208-774-11	RES, CHIP	470 0.50% 1/10W
R119	1-208-776-11	RES, CHIP	560 0.50% 1/10W
R1486	1-216-033-00	RES, CHIP	220 5% 1/10W
R1487	1-216-033-00	RES, CHIP	220 5% 1/10W
R1902	1-216-073-00	RES, CHIP	10K 5% 1/10W
R1904	1-216-073-00	RES, CHIP	10K 5% 1/10W
R1906	1-216-073-00	RES, CHIP	10K 5% 1/10W
R1907	1-216-033-00	RES, CHIP	220 5% 1/10W
R2904	1-216-033-00	RES, CHIP	220 5% 1/10W
R2905	1-216-033-00	RES, CHIP	220 5% 1/10W
R2909	1-216-073-00	RES, CHIP	10K 5% 1/10W
R2910	1-216-073-00	RES, CHIP	10K 5% 1/10W
R2912	1-216-065-91	RES, CHIP	4.7K 5% 1/10W
R2913	1-216-073-00	RES, CHIP	10K 5% 1/10W
R2914	1-216-073-00	RES, CHIP	10K 5% 1/10W
R2915	1-216-073-00	RES, CHIP	10K 5% 1/10W
R2916	1-216-073-00	RES, CHIP	10K 5% 1/10W
TUNER			
TU101	\triangle 8-598-430-00	TUNER, FSS BTF-FA401	



BOARD VARIANT PARTS LIST

The parts on this page belong to the following model(s) only:

**KV-32XBR250/34FX250C/36XBR250/38FX250/
38FX250C/38FX250T**

The components identified by shading and mark Δ are critical for safety. Replace only with part number specified.

Les composants identifiés par un trame et une marque Δ sont critiques pour la sécurité. Ne les remplacer que par une pièce portant le numéro spécifié.

REF.NO.	PART NO.	DESCRIPTION	REMARK
---------	----------	-------------	--------

AK BOARD VARIANT PARTS LIST: KV-32XBR250/34FX250C/36XBR250/38FX250/ 38FX250C/38FX250T
--

CAPACITOR

C101	1-126-960-11	ELECT	1µF	20%	50V
C102	1-164-161-11	CERAMIC	0.0022µF	10%	50V
C104	1-126-964-11	ELECT	10µF	20%	50V
C106	1-104-664-11	ELECT	47µF	20%	25V
C108	1-126-942-61	ELECT	1000µF	20%	25V

C109	1-163-259-91	CERAMIC	220pF	5%	50V
C110	1-163-809-11	CERAMIC	0.047µF	10%	25V
C111	1-126-960-11	ELECT	1µF	20%	50V
C113	1-104-666-11	ELECT	220µF	20%	25V
C115	1-126-960-11	ELECT	1µF	20%	50V

C1904	1-102-129-00	CERAMIC	0.01µF	10%	50V
C1905	1-126-964-11	ELECT	10µF	20%	50V
C1906	1-102-129-00	CERAMIC	0.01µF	10%	50V
C1907	1-126-964-11	ELECT	10µF	20%	50V
C1908	1-163-009-11	CERAMIC	0.001µF	10%	50V

C1909	1-163-009-11	CERAMIC	0.001µF	10%	50V
C1910	1-163-009-11	CERAMIC	0.001µF	10%	50V
C1911	1-163-009-11	CERAMIC	0.001µF	10%	50V
C1912	1-163-009-11	CERAMIC	0.001µF	10%	50V

CONNECTOR

CN1465*	1-564-507-51	PLUG, CONNECTOR 4P
CN1467*	1-564-510-11	PLUG, CONNECTOR 7P
CN1468	1-695-915-11	TAB (CONTACT)

DIODE

D101	8-719-109-89	DIODE RD5.6ESB2
D103	8-719-991-33	DIODE 1SS133T-77
D104	8-719-991-33	DIODE 1SS133T-77
D105	8-719-991-33	DIODE 1SS133T-77
D106	8-719-991-33	DIODE 1SS133T-77

D107	8-719-991-33	DIODE 1SS133T-77
D108	8-719-110-17	DIODE RD10ESB2
D109	8-719-110-17	DIODE RD10ESB2

IC

IC1901	8-752-058-68	IC CXA1315M
IC1902	8-759-470-63	IC NJM2145M-TE2

COIL

L102	1-414-856-11	INDUCTOR	10µH
L105	1-414-857-11	INDUCTOR	100µH

REF.NO.	PART NO.	DESCRIPTION	REMARK
---------	----------	-------------	--------

TRANSISTOR

Q101	8-729-119-78	TRANSISTOR 2SC2785-HFE
Q105	8-729-216-22	TRANSISTOR 2SA1162-G
Q106	8-729-422-27	TRANSISTOR 2SD601A-Q
Q451	8-729-140-97	TRANSISTOR 2SB734-34
Q1902	8-729-216-22	TRANSISTOR 2SA1162-G

Q1903	8-729-216-22	TRANSISTOR 2SA1162-G
Q1918	8-729-216-22	TRANSISTOR 2SA1162-G

RESISTOR

R101	1-216-065-91	RES, CHIP	4.7K	5%	1/10W
R102	1-216-083-00	RES, CHIP	27K	5%	1/10W
R103	1-216-689-11	RES, CHIP	39K	5%	1/10W
R104	1-216-049-91	RES, CHIP	1K	5%	1/10W
R112	1-216-057-00	RES, CHIP	2.2K	5%	1/10W

R113	1-216-097-91	RES, CHIP	100K	5%	1/10W
R114	1-216-121-91	RES, CHIP	1M	5%	1/10W
R115	1-216-073-00	RES, CHIP	10K	5%	1/10W
R116	1-216-073-00	RES, CHIP	10K	5%	1/10W
R117	1-216-065-91	RES, CHIP	4.7K	5%	1/10W

R118	1-208-774-11	RES, CHIP	470	0.50%	1/10W
R119	1-208-776-11	RES, CHIP	560	0.50%	1/10W
R450	1-216-073-00	RES, CHIP	10K	5%	1/10W
R1486	1-216-033-00	RES, CHIP	220	5%	1/10W
R1487	1-216-033-00	RES, CHIP	220	5%	1/10W

R1902	1-216-073-00	RES, CHIP	10K	5%	1/10W
R1904	1-216-073-00	RES, CHIP	10K	5%	1/10W
R1906	1-216-073-00	RES, CHIP	10K	5%	1/10W
R1907	1-216-033-00	RES, CHIP	220	5%	1/10W
R2904	1-216-033-00	RES, CHIP	220	5%	1/10W

R2905	1-216-033-00	RES, CHIP	220	5%	1/10W
R2909	1-216-073-00	RES, CHIP	10K	5%	1/10W
R2910	1-216-073-00	RES, CHIP	10K	5%	1/10W
R2912	1-216-065-91	RES, CHIP	4.7K	5%	1/10W
R2913	1-216-073-00	RES, CHIP	10K	5%	1/10W

R2914	1-216-073-00	RES, CHIP	10K	5%	1/10W
R2915	1-216-073-00	RES, CHIP	10K	5%	1/10W
R2916	1-216-073-00	RES, CHIP	10K	5%	1/10W

TUNER

TU101	Δ 8-598-430-00	TUNER, FSS BTF-FA401
-------	-----------------------	----------------------

The components identified by shading and mark \triangle are critical for safety. Replace only with part number specified.

Les composants identifiés per un trame et une marque \triangle sont critiques pour la securite. Ne les remplacer que par une piece portant le numero specifie.

C G

COMPLETE PARTS LISTING

REF.NO.	PART NO.	DESCRIPTION	REMARK	REF.NO.	PART NO.	DESCRIPTION	REMARK
C							
*	A-1331-942-A C BOARD, COMPLETE (All Models)						
	4-382-854-11	SCREW (M3X10), P, SW (+)					
CAPACITOR							
C1750	1-137-528-11	FILM	0.1 μ F 10% 250V				
C1751	1-107-655-11	ELECT	47 μ F 20% 250V				
C1790	1-102-129-00	CERAMIC	0.01 μ F 10% 50V				
C1791	1-126-968-11	ELECT	100 μ F 20% 50V				
C1792	1-102-106-00	CERAMIC	100pF 10% 50V				
C1794	1-107-651-11	ELECT	4.7 μ F 20% 250V				
C1795	1-102-074-00	CERAMIC	0.001 μ F 10% 50V				
C1799	1-162-114-00	CERAMIC	0.0047 μ F 2KV				
CONNECTOR							
	CN1761*1-564-509-11	PLUG, CONNECTOR 6P					
	CN1764*1-564-508-11	PLUG, CONNECTOR 5P					
	CN1766	1-695-915-11 TAB (CONTACT)					
DIODE							
D1790	8-719-991-33	DIODE 1SS133T-77					
D1791	8-719-908-03	DIODE GP08D					
D1792	8-719-908-03	DIODE GP08D					
D1793	8-719-908-03	DIODE GP08D					
D1794	8-719-908-03	DIODE GP08D					
IC							
	IC1701 \triangle 8-759-562-43	IC TDA6108JF/N1B					
JACK							
	J1761 \triangle 1-540-071-22	SOCKET, CRT					
COIL							
L1790	1-412-537-31	INDUCTOR	100 μ H				
TRANSISTOR							
Q1790	8-729-119-76	TRANSISTOR 2SA1175-HFE					
RESISTOR							
R1750	1-247-870-11	CARBON	43K 5% 1/4W				
R1751	1-247-807-31	CARBON	100 5% 1/4W				
R1752	1-247-807-31	CARBON	100 5% 1/4W				
R1753 \triangle	1-247-807-31	CARBON	100 5% 1/4W				
R1763	1-260-099-11	CARBON	1K 5% 1/2W				
R1764	1-247-807-31	CARBON	100 5% 1/4W				
R1773	1-260-099-11	CARBON	1K 5% 1/2W				
R1774	1-247-807-31	CARBON	100 5% 1/4W				
R1783	1-260-099-11	CARBON	1K 5% 1/2W				
R1784	1-247-807-31	CARBON	100 5% 1/4W				
R1788	1-216-349-00	METAL OXIDE	1 5% 1W F				
R1789	1-249-437-11	CARBON	47K 5% 1/4W				
R1792	1-247-815-91	CARBON	220 5% 1/4W				
R1793	1-247-866-11	CARBON	30K 5% 1/4W				
R1794	1-260-132-11	CARBON	560K 5% 1/2W				
R1795	1-260-087-11	CARBON	100 5% 1/2W				
R1796 \triangle	1-216-374-00	METAL OXIDE	2.7 5% 2W F				
R1797	1-260-123-11	CARBON	100K 5% 1/2W				
VARIABLE RESISTOR							
	RV1761	1-241-714-11 RES, ADJ, METAL FILM 110M					
G							
*	A-1316-397-A G BOARD, COMPLETE (KV-32FS10/32FV15/32XBR250/36FS10/36FV15/36XBR250 only)						
*	A-1316-423-A G BOARD, COMPLETE (KV-34FV15T/38FX250T only)						
	1-533-223-11	HOLDER, FUSE					
	4-382-854-11	SCREW (M3X10), P, SW (+)					
CAPACITOR							
C601	1-136-346-21	FILM	0.22 μ F 20% 125V				
C602	1-126-964-11	ELECT	10 μ F 20% 50V				
C603 \triangle	1-127-790-51	CERAMIC	1000pF 20% 250V				
	(KV-32FS10/32FV15/32XBR250/36FS10/36FV15/36XBR250 only)						
C603 \triangle	1-127-794-51	CERAMIC	2200pF 20% 250V				
	(KV-34FV15T/38FX250T only)						
C604 \triangle	1-136-346-21	FILM	0.22 μ F 20% 125V				
	(KV-32FS10/32FV15/32XBR250/36FS10/36FV15/36XBR250 only)						
C604 \triangle	1-136-311-11	FILM	0.47 μ F 20% 125V				
	(KV-34FV15T/38FX250T only)						
C605 \triangle	1-136-346-21	FILM	0.22 μ F 20% 125V				
	(KV-32FS10/32FV15/32XBR250/36FS10/36FV15/36XBR250 only)						
C605 \triangle	1-136-311-11	FILM	0.47 μ F 20% 125V				
	(KV-34FV15T/38FX250T only)						
C606 \triangle	1-117-894-11	ELECT	560 μ F 20% 250V				
C607 \triangle	1-117-894-11	ELECT	560 μ F 20% 250V				
C608	1-107-824-11	CERAMIC	220pF 5% 1KV				
C609	1-136-176-00	FILM	0.82 μ F 5% 50V				
C610	1-136-176-00	FILM	0.82 μ F 5% 50V				
C611	1-136-169-00	FILM	0.22 μ F 5% 50V				
C612	1-136-169-00	FILM	0.22 μ F 5% 50V				
C613	1-164-646-11	CERAMIC	2200pF 10% 500V				
C614	1-126-963-11	ELECT	4.7 μ F 20% 50V				
C615	1-117-976-11	FILM	0.039 μ F 5% 800V				
C616 \triangle	1-127-790-51	CERAMIC	1000pF 20% 250V				
	(KV-32FS10/32FV15/32XBR250/36FS10/36FV15/36XBR250 only)						

G**COMPLETE PARTS LISTING**

The components identified by shading and mark Δ are critical for safety. Replace only with part number specified.

Les composants identifiés par un trame et une marque Δ sont critiques pour la sécurité. Ne les remplacer que par une pièce portant le numéro spécifié.

REF.NO.	PART NO.	DESCRIPTION	REMARK
C616 Δ	1-127-794-51	CERAMIC 2200pF 20%	250V
(KV-34FV15T/38FX250T only)			
C618	1-126-968-11	ELECT 100 μ F 20%	50V
C624	1-126-960-11	ELECT 1 μ F 20%	50V
C629 Δ	1-107-652-11	ELECT 10 μ F 20%	250V
C630	1-130-471-00	MYLAR 0.001 μ F 5%	50V
C631	1-137-605-11	FILM 0.01 μ F 10%	250V
C633	1-130-471-00	MYLAR 0.001 μ F 5%	50V
C634	1-130-467-00	MYLAR 470pF 5%	50V
C635	1-130-471-00	MYLAR 0.001 μ F 5%	50V
C636	1-126-965-11	ELECT 22 μ F 20%	50V
C637	1-126-940-11	ELECT 330 μ F 20%	25V
C641	1-128-550-11	ELECT 2200 μ F 20%	50V
C643	1-107-995-11	ELECT 100 μ F 0	160V
C644	1-104-664-11	ELECT 47 μ F 20%	25V
C647	1-104-665-11	ELECT 100 μ F 20%	25V
C650	1-104-664-11	ELECT 47 μ F 20%	25V
C651	1-130-477-00	MYLAR 0.0033 μ F 5%	50V
C652	1-106-351-00	MYLAR 0.0022 μ F 20%	200V
C653	1-107-636-11	ELECT 10 μ F 20%	160V
C656	1-126-964-11	ELECT 10 μ F 20%	50V
C657	1-137-372-11	FILM 0.022 μ F 5%	50V
C658	1-126-941-11	ELECT 470 μ F 20%	25V
C660	1-126-936-11	ELECT 3300 μ F 20%	16V
C661	1-104-664-11	ELECT 47 μ F 20%	25V
C662	1-126-933-11	ELECT 100 μ F 20%	16V
C665	1-104-664-11	ELECT 47 μ F 20%	25V
C695	1-164-625-11	CERAMIC 680pF 10%	500V
C696	1-164-625-11	CERAMIC 680pF 10%	500V
C697	1-164-625-11	CERAMIC 680pF 10%	500V
C698	1-164-625-11	CERAMIC 680pF 10%	500V
C699	1-136-169-00	FILM 0.22 μ F 5%	50V

CONNECTOR

CN601 *	1-573-963-11	PIN, CONNECTOR (PC BOARD) 3P
CN602 *	1-580-844-11	PIN, CONNECTOR (POWER)
CN603 *	1-573-963-11	PIN, CONNECTOR (PC BOARD) 3P
CN641 *	1-564-515-11	PLUG, CONNECTOR 12P
CN642 *	1-564-509-11	PLUG, CONNECTOR 6P
CN643 *	1-508-786-00	PIN, CONNECTOR (5MM PITCH) 2P
CN645	1-695-915-11	TAB (CONTACT)
CN646	1-695-915-11	TAB (CONTACT)

DIODE

D600	8-719-991-33	DIODE 1SS133T-77
D601	8-719-991-33	DIODE 1SS133T-77
D602 Δ	8-719-510-53	DIODE D4SB60L
D603	8-719-063-70	DIODE D1NL20U
D604	8-719-991-33	DIODE 1SS133T-77
D605	8-719-923-83	DIODE MTZJ-T-77-13A
D606	8-719-110-60	DIODE RD24ESB
D607	8-719-109-97	DIODE RD6.8ESB2
D608	8-719-109-97	DIODE RD6.8ESB2

REF.NO.	PART NO.	DESCRIPTION	REMARK
D612	8-719-991-33	DIODE 1SS133T-77	
D613	8-719-991-33	DIODE 1SS133T-77	
D614	8-719-991-33	DIODE 1SS133T-77	
D621	8-719-911-55	DIODE U05G	
D622	8-719-911-55	DIODE U05G	
D623	8-719-948-45	DIODE ERA22-08	
D624	8-719-991-33	DIODE 1SS133T-77	
D625	8-719-991-33	DIODE 1SS133T-77	
D626	8-719-109-93	DIODE RD6.2ESB2	
D627	8-719-510-48	DIODE D1N20R	
D628	8-719-510-02	DIODE D1NS4	
D629	8-719-052-90	DIODE D1NL40-TA2	
D630	8-719-052-90	DIODE D1NL40-TA2	
D641	8-719-060-89	DIODE D4SBS6-F	
D642	8-719-510-12	DIODE D10SC4M	
D643	8-719-062-40	DIODE D4SBL20UF3	
D647	8-719-063-70	DIODE D1NL20U	
D648 Δ	8-719-057-52	DIODE EZ0150AV1	
D651	8-719-510-02	DIODE D1NS4	
D652	8-719-510-02	DIODE D1NS4	
D653	8-719-991-33	DIODE 1SS133T-77	
D698	8-719-991-33	DIODE 1SS133T-77	
D699	8-719-923-86	DIODE MTZJ-T-77-15	

FUSE

F601 Δ 1-532-506-51 FUSE 6.3A/250V

FERRITE BEAD

FB601	1-410-396-41	FERRITE	0.45 μ H
FB602	1-410-396-41	FERRITE	0.45 μ H
FB603	1-410-396-41	FERRITE	0.45 μ H
FB604	1-410-396-41	FERRITE	0.45 μ H
FB641	1-410-397-21	FERRITE	1.1 μ H
FB642	1-410-397-21	FERRITE	1.1 μ H
FB645	1-410-397-21	FERRITE	1.1 μ H
FB647	1-410-397-21	FERRITE	1.1 μ H

IC

IC601 Δ	8-729-045-41	TRANSISTOR MX0842B-F
IC622	8-759-450-47	IC BA05T
IC641	8-759-198-03	IC PQ09RF21
IC643	1-810-051-11	POWER MODULE DM-48
IC650	8-759-394-35	IC BA12T
IC651	8-759-450-47	IC BA05T

COIL

L642	1-412-529-11	INDUCTOR	22 μ H
L650	1-412-519-11	INDUCTOR	3.3 μ H
L651	1-412-519-11	INDUCTOR	3.3 μ H
L652	1-412-519-11	INDUCTOR	3.3 μ H

The components identified by shading and mark Δ are critical for safety. Replace only with part number specified.

Les composants identifiés par un trame et une marque Δ sont critiques pour la securite. Ne les remplacer que par une piece portant le numero specifie.

COMPLETE PARTS LISTING

G

REF.NO.	PART NO.	DESCRIPTION	REMARK	REF.NO.	PART NO.	DESCRIPTION	REMARK
TRANSISTOR							
Q621	Δ 8-729-044-30	TRANSISTOR 2SK2845-LB102		R640	1-215-485-00	METAL	470K 1% 1/4W
Q622	8-729-119-78	TRANSISTOR 2SC2785-HFE		R641	1-247-843-11	CARBON	3.3K 5% 1/4W
Q623	8-729-119-78	TRANSISTOR 2SC2785-HFE		R642	1-247-843-11	CARBON	3.3K 5% 1/4W
Q624	8-729-119-76	TRANSISTOR 2SA1175-HFE		R643	1-249-387-11	CARBON	3.3 5% 1/2W F
Q644	8-729-119-78	TRANSISTOR 2SC2785-HFE		R644	1-249-417-11	CARBON	1K 5% 1/4W
Q645	8-729-119-76	TRANSISTOR 2SA1175-HFE		R645	1-249-429-11	CARBON	10K 5% 1/4W
Q646	8-729-119-76	TRANSISTOR 2SA1175-HFE		R646	1-249-417-11	CARBON	1K 5% 1/4W
Q647	8-729-119-78	TRANSISTOR 2SC2785-HFE		R648	1-249-441-11	CARBON	100K 5% 1/4W
Q648	8-729-922-39	TRANSISTOR 2SD2144S-V		R649	1-249-425-11	CARBON	4.7K 5% 1/4W F
Q649	8-729-119-76	TRANSISTOR 2SA1175-HFE		R650	1-249-421-11	CARBON	2.2K 5% 1/4W
Q650	8-729-119-78	TRANSISTOR 2SC2785-HFE		R651	1-215-908-00	METAL OXIDE	33 5% 3W F
Q651	8-729-802-71	TRANSISTOR 2SA1407-E		R652	Δ 1-216-363-00	METAL OXIDE	0.33 5% 2W F
Q652	8-729-119-76	TRANSISTOR 2SA1175-HFE		R653	1-215-423-00	METAL	1.2K 1% 1/4W
Q653	8-729-119-78	TRANSISTOR 2SC2785-HFE		R654	1-215-481-00	METAL	330K 1% 1/4W
RESISTOR							
R601	Δ 1-249-377-11	CARBON	0.47 5% 1/4W F	R655	1-215-469-00	METAL	100K 1% 1/4W
R602	1-249-429-11	CARBON	10K 5% 1/4W	R656	1-249-427-11	CARBON	6.8K 5% 1/4W
R603	Δ 1-219-776-11	CARBON	2.2M 10% 1/2W	R657	1-249-421-11	CARBON	2.2K 5% 1/4W
R604	1-249-429-11	CARBON	10K 5% 1/4W	R659	1-249-429-11	CARBON	10K 5% 1/4W
R605	1-249-429-11	CARBON	10K 5% 1/4W	R660	1-249-393-11	CARBON	10 5% 1/4W F
R606	1-249-421-11	CARBON	2.2K 5% 1/4W	R661	Δ 1-249-419-11	CARBON	1.5K 5% 1/4W F
R607	Δ 1-202-933-61	FUSIBLE	0.1 10% 1/2W F	R662	1-215-485-00	METAL	470K 1% 1/4W
R608	1-216-369-00	METAL OXIDE	1 5% 2W F	R663	1-215-445-00	METAL	10K 1% 1/4W
R609	1-249-417-11	CARBON	1K 5% 1/4W	R664	Δ 1-240-257-11	CMT,MELF	3.9 5% 20W
R610	1-249-425-11	CARBON	4.7K 5% 1/4W	R665	1-249-425-11	CARBON	4.7K 5% 1/4W
R611	1-216-369-00	METAL OXIDE	1 5% 2W F	R670	1-260-312-11	CARBON	47 5% 1/2W
R612	1-260-124-11	CARBON	120K 5% 1/2W	R671	1-260-312-11	CARBON	47 5% 1/2W
R613	1-260-124-11	CARBON	120K 5% 1/2W	R680	1-216-364-11	METAL OXIDE	0.39 5% 2W F
R614	1-260-124-11	CARBON	120K 5% 1/2W	R681	1-216-365-00	METAL OXIDE	0.47 5% 2W F
R615	1-260-124-11	CARBON	120K 5% 1/2W	R699	1-249-429-11	CARBON	10K 5% 1/4W
R618	1-249-425-11	CARBON	4.7K 5% 1/4W	RELAY			
R619	1-249-425-11	CARBON	4.7K 5% 1/4W	RY600	Δ 1-755-266-11	RELAY, AC POWER	
R620	1-126-967-11	ELECT	47 μ F 20% 50V	RY601	Δ 1-755-146-11	RELAY, AC POWER	
R621	1-249-429-11	CARBON	10K 5% 1/4W	TRANSFORMER			
R622	1-247-863-91	CARBON	22K 5% 1/4W	T601	Δ 1-426-717-11	TRANSFORMER, LINE FILTER (LFT)	
R623	Δ 1-240-257-11	CMT,MELF	3.9 5% 20W	T602	Δ 1-426-717-11	TRANSFORMER, LINE FILTER (LFT)	
R624	Δ 1-215-485-00	METAL	470K 1% 1/4W	T603	Δ 1-429-992-21	TRANSFORMER, CONVERTER (PRT)	
R625	Δ 1-215-485-00	METAL	470K 1% 1/4W	T605	Δ 1-433-408-11	TRANSFORMER, CONVERTER (PIT)	
R626	1-249-425-11	CARBON	4.7K 5% 1/4W	T621	Δ 1-431-852-11	TRANSFORMER, CONVERTER (SRT)	
R627	1-249-405-11	CARBON	100 5% 1/4W F	THERMISTOR			
R631	1-240-205-91	CARBON	22M 5% 1/2W	THP601	Δ 1-809-539-11	THERMISTOR, POSITIVE	
R632	1-249-421-11	CARBON	2.2K 5% 1/4W	THP602	Δ 1-809-539-11	THERMISTOR, POSITIVE	
R633	1-249-429-11	CARBON	10K 5% 1/4W	VARISTOR			
R634	1-249-437-11	CARBON	47K 5% 1/4W	VDR601	Δ 1-801-074-41	VARISTOR ERZV10D271	
R635	1-247-791-91	CARBON	22 5% 1/4W	VDR602	Δ 1-801-074-41	VARISTOR ERZV10D271	
R636	1-249-415-11	CARBON	680 5% 1/4W				
R637	1-260-302-51	CARBON	6.8 5% 1/2W				
R638	1-249-413-11	CARBON	470 5% 1/4W				
R639	Δ 1-249-389-11	CARBON	4.7 5% 1/4W F				

GA COMPLETE PARTS LISTINGThe components identified by shading and mark Δ are critical for safety. Replace only with part number specified.Les composants identifiés par un trame et une marque Δ sont critiques pour la sécurité. Ne les remplacer que par une pièce portant le numéro spécifique.

REF.NO. PART NO. DESCRIPTION REMARK

GA* A-1316-470-A GA BOARD, COMPLETE
(KV-34FV10/34FV15/34FV15C/34FV15K/34FX250C/38FX250/
38FX250C/38FV15K only)1-533-223-11 HOLDER, FUSE
1-923-083-07 WIRE UL1007 AWG24 70MM RED
* 4-374-846-01 COVER, CAPACITOR, CAP TYPE
4-382-854-11 SCREW (M3X10), P, SW (+)**CAPACITOR**

C6001	1-126-933-11	ELECT	100µF	20%	16V
C6002	Δ 1-136-346-21	FILM	0.22µF	20%	300V
C6003	1-136-346-21	FILM	0.22µF	20%	300V
C6005	Δ 1-119-886-51	CERAMIC	470pF	10%	250V
C6007	Δ 1-119-886-51	CERAMIC	470pF	10%	250V
C6008	1-126-960-11	ELECT	1µF	20%	50V
C6009	1-126-961-11	ELECT	2.2µF	20%	50V
C6016	1-104-330-91	CERAMIC	470pF	10%	1KV
C6017	Δ 1-130-029-00	FILM	8200pF	2%	50V
C6018	1-102-050-00	CERAMIC	0.01µF	20%	500V
C6019	Δ 1-113-611-11	ELECT(BLOCK)	820µF	20%	250V
C6020	Δ 1-113-611-11	ELECT(BLOCK)	820µF	20%	250V
C6021	1-126-964-11	ELECT	10µF	20%	50V
C6022	Δ 1-126-963-11	ELECT	4.7µF	20%	50V
C6024	1-126-964-11	ELECT	10µF	20%	50V
C6025	1-119-769-11	FILM	0.018µF	3%	1KV
C6026	1-126-964-11	ELECT	10µF	20%	50V
C6027	1-130-471-00	MYLAR	0.001µF	5%	50V
C6028	1-130-471-00	MYLAR	0.001µF	5%	50V
C6029	Δ 1-136-165-00	FILM	0.1µF	5%	50V
C6030	1-119-769-11	FILM	0.018µF	3%	1KV
C6031	1-104-330-91	CERAMIC	470pF	10%	1KV
C6032	1-126-960-11	ELECT	1µF	20%	50V
C6035	1-127-794-51	CERAMIC	2200pF	20%	250V
C6036	1-127-794-51	CERAMIC	2200pF	20%	250V
C6037	Δ 1-107-679-91	ELECT	10µF	20%	450V
C6038	1-137-370-11	FILM	0.01µF	5%	50V
C6039	1-164-645-11	CERAMIC	1000pF	10%	500V
C6040	1-130-467-00	MYLAR	470pF	5%	50V
C6042	1-130-467-00	MYLAR	470pF	5%	50V
C6043	1-130-471-00	MYLAR	0.001µF	5%	50V
C6044	1-126-936-11	ELECT	3300µF	20%	16V
C6045	1-126-942-61	ELECT	1000µF	20%	25V
C6046	1-128-566-11	ELECT	470µF	20%	100V
C6047	1-128-566-11	ELECT	470µF	20%	100V
C6048	1-164-645-11	CERAMIC	1000pF	10%	500V
C6049	1-128-550-11	ELECT	2200µF	20%	50V
C6050	1-104-664-11	ELECT	47µF	20%	25V
C6051	1-104-664-11	ELECT	47µF	20%	25V
C6052	1-126-971-11	ELECT	470µF	20%	50V

REF.NO. PART NO. DESCRIPTION REMARK

C6053	1-136-165-00	FILM	0.1µF	5%	50V
C6054	1-137-605-11	FILM	0.01µF	10%	250V
C6056	1-130-471-00	MYLAR	0.001µF	5%	50V
C6057	1-107-636-11	ELECT	10µF	20%	160V
C6058	1-126-960-11	ELECT	1µF	20%	50V
C6059	1-104-664-11	ELECT	47µF	20%	25V
C6060	1-104-664-11	ELECT	47µF	20%	25V
C6062	1-126-964-11	ELECT	10µF	20%	50V
C6063	1-126-940-11	ELECT	330µF	20%	25V
C6064	1-104-664-11	ELECT	47µF	20%	25V
C6066	1-126-965-11	ELECT	22µF	20%	50V
C6067	1-102-121-00	CERAMIC	0.0022µF	10%	50V
C6068	1-102-106-00	CERAMIC	100pF	10%	50V
C6069	1-102-106-00	CERAMIC	100pF	10%	50V
C6070	1-102-074-00	CERAMIC	0.001µF	10%	50V
C6071	1-102-106-00	CERAMIC	100pF	10%	50V
C6072	1-102-106-00	CERAMIC	100pF	10%	50V
C6073	1-102-129-00	CERAMIC	0.01µF	10%	50V
C6074	1-102-106-00	CERAMIC	100pF	10%	50V
C6075	1-107-824-11	CERAMIC	220pF	5%	1KV
C6078	1-126-964-11	ELECT	10µF	20%	50V

CONNECTOR

CN6000*	1-573-963-11	PIN, CONNECTOR (PC BOARD)	3P
CN6001*	1-573-963-11	PIN, CONNECTOR (PC BOARD)	3P
CN6002	1-695-915-11	TAB (CONTACT)	
CN6003*	1-580-843-11	PIN, CONNECTOR (POWER)	
CN6006*	1-564-509-11	PLUG, CONNECTOR 6P	
CN6007*	1-564-515-11	PLUG, CONNECTOR 12P	
CN6009	1-695-915-11	TAB (CONTACT)	

DIODE

D6000	8-719-991-33	DIODE 1SS133T-77	
D6001	8-719-991-33	DIODE 1SS133T-77	
D6002	8-719-991-33	DIODE 1SS133T-77	
D6003	8-719-991-33	DIODE 1SS133T-77	
D6004	8-719-991-33	DIODE 1SS133T-77	
D6005	8-719-991-33	DIODE 1SS133T-77	
D6006	8-719-991-33	DIODE 1SS133T-77	
D6008	Δ 8-719-510-53	DIODE D4SB60L	
D6009	8-719-991-33	DIODE 1SS133T-77	
D6010	8-719-991-33	DIODE 1SS133T-77	
D6011	8-719-991-33	DIODE 1SS133T-77	
D6012	8-719-991-33	DIODE 1SS133T-77	
D6013	Δ 8-719-510-02	DIODE D1NS4	
D6014	Δ 8-719-921-88	DIODE MTZJ-13B	
D6015	8-719-979-64	DIODE UF4005PKG23	
D6016	8-719-924-13	DIODE MTZJ-T-77-22B	
D6017	8-719-911-55	DIODE U05G	
D6018	8-719-924-13	DIODE MTZJ-T-77-22B	
D6019	8-719-911-55	DIODE U05G	
D6020	Δ 8-719-062-40	DIODE D4SBL20UF3	

The components identified by shading and mark Δ are critical for safety. Replace only with part number specified.

Les composants identifiés par un trame et une marque Δ sont critiques pour la securite. Ne les remplacer que par une piece portant le numero specifie.

COMPLETE PARTS LISTING



REF.NO.	PART NO.	DESCRIPTION	REMARK
D6021	8-719-110-41	DIODE RD15ESB2	
D6022	8-719-510-12	DIODE D10SC4M	
D6023	Δ 8-719-022-97	DIODE D2S4MF	
D6024	Δ 8-719-022-97	DIODE D2S4MF	
D6025	Δ 8-719-060-89	DIODE D4SBS6-F	
D6028	8-719-110-49	DIODE RD18ESB2	
D6029	8-719-991-33	DIODE 1SS133T-77	
D6030	Δ 8-719-110-60	DIODE RD24ESB	
D6031	8-719-991-33	DIODE 1SS133T-77	
D6032	8-719-510-48	DIODE D1N20R	
D6034	8-719-948-45	DIODE ERA22-08	
D6035	8-719-063-70	DIODE D1NL20U	
D6036	8-719-032-12	DIODE D1NS6	
D6037	8-719-991-33	DIODE 1SS133T-77	
D6038	8-719-991-33	DIODE 1SS133T-77	
D6040	8-719-063-70	DIODE D1NL20U	
D6041	8-719-991-33	DIODE 1SS133T-77	
D6042	8-719-110-17	DIODE RD10ESB2	
D6043	8-719-991-33	DIODE 1SS133T-77	
D6044	8-719-991-33	DIODE 1SS133T-77	
D6045	8-719-911-55	DIODE U05G	
D6046	8-719-911-55	DIODE U05G	
D6047	8-719-110-31	DIODE RD12ESB2	
D6048	8-719-110-31	DIODE RD12ESB2	
D6049	8-719-991-33	DIODE 1SS133T-77	
D6050	Δ 8-719-979-64	DIODE UF4005PKG23	
D6051	8-719-063-70	DIODE D1NL20U	
D6052	8-719-110-31	DIODE RD12ESB2	

FUSE

F6001	Δ 1-532-506-51	FUSE	6.3A/250V
-------	-----------------------	------	-----------

FERRITE BEAD

FB6001	1-412-911-11	FERRITE	
FB6002	1-412-911-11	FERRITE	
FB6003	1-412-911-11	FERRITE	
FB6004	1-412-911-11	FERRITE	
FB6005	1-412-911-11	FERRITE	
FB6006	1-412-911-11	FERRITE	
FB6007	1-412-911-11	FERRITE	

IC

IC6000	8-759-198-31	IC UPC1093J-1-T	
IC6001	Δ 8-759-133-90	IC UPC339C	
IC6002	Δ 8-749-013-78	IC MCR5102	
IC6003	8-749-012-13	IC DM-58	
IC6004	8-759-394-35	IC BA12T	
IC6005	8-759-198-03	IC PQ09RF21	
IC6007	8-759-450-47	IC BA05T	

REF.NO.	PART NO.	DESCRIPTION	REMARK
COIL			
L6000	1-412-519-11	INDUCTOR	3.3 μ H
L6001	1-412-519-11	INDUCTOR	3.3 μ H
L6002	1-412-527-11	INDUCTOR	15 μ H
L6003	1-412-527-11	INDUCTOR	15 μ H
L6004	1-412-529-11	INDUCTOR	22 μ H
PHOTO COUPLER			
PH6001	Δ 8-749-924-35	PHOTO COUPLER ON3171-R	
PH6002	Δ 8-749-924-35	PHOTO COUPLER ON3171-R	
TRANSISTOR			
Q6000	8-729-119-78	TRANSISTOR 2SC2785-HFE	
Q6001	8-729-119-78	TRANSISTOR 2SC2785-HFE	
Q6002	8-729-119-76	TRANSISTOR 2SA1175-HFE	
Q6003	8-729-119-76	TRANSISTOR 2SA1175-HFE	
Q6004	8-729-119-78	TRANSISTOR 2SC2785-HFE	
Q6005	8-729-119-78	TRANSISTOR 2SC2785-HFE	
Q6006	Δ 8-729-046-40	TRANSISTOR 2SK2663	
Q6007	8-729-922-39	TRANSISTOR 2SD2144S-V	
Q6008	8-729-119-76	TRANSISTOR 2SA1175-HFE	
Q6009	8-729-048-82	TRANSISTOR 2SA821STPQ	
Q6010	8-729-119-78	TRANSISTOR 2SC2785-HFE	
Q6011	Δ 8-729-140-93	TRANSISTOR 2SB733-34	
Q6012	8-729-119-76	TRANSISTOR 2SA1175-HFE	
RESISTOR			
R6000	1-215-445-00	METAL	10K 1% 1/4W
R6001	1-215-445-00	METAL	10K 1% 1/4W
R6002	1-202-727-00	SOLID	4.7M 20% 1/2W
R6003	1-249-425-11	CARBON	4.7K 5% 1/4W
R6004	1-247-843-11	CARBON	3.3K 5% 1/4W
R6005	1-215-469-00	METAL	100K 1% 1/4W
R6006	1-215-471-00	METAL	120K 1% 1/4W
R6007	1-247-843-11	CARBON	3.3K 5% 1/4W
R6008	1-215-469-00	METAL	100K 1% 1/4W
R6009	1-215-483-00	METAL	390K 1% 1/4W
R6010	1-249-393-11	CARBON	10 5% 1/4W F
R6011	1-215-466-00	METAL	75K 1% 1/4W
R6012	1-215-489-00	METAL	680K 1% 1/4W
R6013	1-215-489-00	METAL	680K 1% 1/4W
R6014	1-215-489-00	METAL	680K 1% 1/4W
R6015	1-215-485-00	METAL	470K 1% 1/4W
R6016	1-215-471-00	METAL	120K 1% 1/4W
R6017	1-215-489-00	METAL	680K 1% 1/4W
R6018	1-215-489-00	METAL	680K 1% 1/4W
R6019	1-215-489-00	METAL	680K 1% 1/4W
R6020	Δ 1-218-265-11	METAL	8.2M 5% 1W
R6021	1-215-466-00	METAL	75K 1% 1/4W
R6022	1-215-469-00	METAL	100K 1% 1/4W
R6023	1-215-465-00	METAL	68K 1% 1/4W

GA COMPLETE PARTS LISTING

The components identified by shading and mark Δ are critical for safety. Replace only with part number specified.

Les composants identifiés par un trame et une marque Δ sont critiques pour la sécurité. Ne les remplacer que par une pièce portant le numéro spécifié.

REF.NO.	PART NO.	DESCRIPTION	REMARK
R6024	1-215-457-00	METAL 33K	1% 1/4W
R6025	1-215-473-00	METAL 150K	1% 1/4W
R6026	1-215-466-00	METAL 75K	1% 1/4W
R6027	1-215-489-00	METAL 680K	1% 1/4W
R6028	1-215-489-00	METAL 680K	1% 1/4W
R6029	1-215-489-00	METAL 680K	1% 1/4W
R6030	1-215-458-00	METAL 36K	1% 1/4W
R6031	1-215-489-00	METAL 680K	1% 1/4W
R6032	1-215-489-00	METAL 680K	1% 1/4W
R6033	1-215-489-00	METAL 680K	1% 1/4W
R6034	1-215-463-00	METAL 56K	1% 1/4W
R6035	1-249-429-11	CARBON 10K	5% 1/4W
R6036	1-215-481-00	METAL 330K	1% 1/4W
R6037	1-249-439-11	CARBON 68K	5% 1/4W
R6038	1-215-481-00	METAL 330K	1% 1/4W
R6039 Δ	1-240-876-11	CEMENTED 1	5% 15W
R6040 Δ	1-240-876-11	CEMENTED 1	5% 15W
R6041	1-219-512-11	CARBON 2.2M	5% 1/2W
R6042	1-247-863-91	CARBON 22K	5% 1/4W
R6044 Δ	1-215-430-00	METAL 2.4K	1% 1/4W
R6045	1-215-448-00	METAL 13K	1% 1/4W
R6046	1-247-863-91	CARBON 22K	5% 1/4W
R6047	1-215-481-00	METAL 330K	1% 1/4W
R6048 Δ	1-260-131-11	CARBON 470K	5% 1/2W
R6049 Δ	1-260-131-11	CARBON 470K	5% 1/2W
R6050	1-249-425-11	CARBON 4.7K	5% 1/4W
R6051 Δ	1-202-933-61	FUSIBLE 0.1	10% 1/2W F
R6052	1-249-429-11	CARBON 10K	5% 1/4W
R6053	1-249-425-11	CARBON 4.7K	5% 1/4W
R6054	1-249-437-11	CARBON 47K	5% 1/4W
R6055	1-249-429-11	CARBON 10K	5% 1/4W
R6056	1-215-421-00	METAL 1K	1% 1/4W
R6057	1-249-429-11	CARBON 10K	5% 1/4W
R6058 Δ	1-216-381-11	METAL OXIDE 0.22	5% 3W F
R6059	1-215-864-00	METAL OXIDE 150	5% 1W F
R6060 Δ	1-216-381-11	METAL OXIDE 0.22	5% 3W F
R6062	1-219-512-11	CARBON 2.2M	5% 1/2W
R6063	1-215-421-00	METAL 1K	1% 1/4W
R6064 Δ	1-247-815-91	CARBON 220	5% 1/4W
R6065	1-247-815-91	CARBON 220	5% 1/4W
R6066	1-249-389-11	CARBON 4.7	5% 1/4W F
R6067	1-249-421-11	CARBON 2.2K	5% 1/4W
R6068	1-249-417-11	CARBON 1K	5% 1/4W
R6069	1-249-437-11	CARBON 47K	5% 1/4W
R6071	1-249-425-11	CARBON 4.7K	5% 1/4W
R6072	1-247-815-91	CARBON 220	5% 1/4W
R6073	1-260-298-51	CARBON 3.3	5% 1/2W F
R6074	1-249-415-11	CARBON 680	5% 1/4W
R6075	1-260-312-11	CARBON 47	5% 1/2W
R6076	1-260-312-11	CARBON 47	5% 1/2W
R6077	1-247-791-91	CARBON 22	5% 1/4W
R6078 Δ	1-249-389-11	CARBON 4.7	5% 1/4W F
R6079	1-247-815-91	CARBON 220	5% 1/4W

REF.NO.	PART NO.	DESCRIPTION	REMARK
R6080	1-249-421-11	CARBON 2.2K	5% 1/4W
R6081 Δ	1-249-387-11	CARBON 3.3	5% 1/2W F
R6082	1-215-461-00	METAL 47K	1% 1/4W
R6083	1-249-441-11	CARBON 100K	5% 1/4W
R6084	1-249-413-11	CARBON 470	5% 1/4W
R6085	1-215-462-00	METAL 51K	1% 1/4W
R6086	1-215-479-00	METAL 270K	1% 1/4W
R6087	1-240-205-91	CARBON 22M	5% 1/2W
R6088 Δ	1-249-417-11	CARBON 1K	5% 1/4W F
R6089	1-215-493-00	METAL 1M	1% 1/4W
R6091	1-215-469-00	METAL 100K	1% 1/4W
R6092	1-215-481-00	METAL 330K	1% 1/4W
R6093	1-249-427-11	CARBON 6.8K	5% 1/4W
R6094	1-215-423-00	METAL 1.2K	1% 1/4W
R6095 Δ	1-216-363-00	METAL OXIDE 0.33	5% 2W F
R6096	1-249-421-11	CARBON 2.2K	5% 1/4W
R6097	1-215-485-00	METAL 470K	1% 1/4W
R6098	1-215-445-00	METAL 10K	1% 1/4W
R6099	1-215-469-00	METAL 100K	1% 1/4W
R6100	1-249-429-11	CARBON 10K	5% 1/4W
R6101	1-249-417-11	CARBON 1K	5% 1/4W
R6102	1-247-895-91	CARBON 470K	5% 1/4W
R6103	1-205-998-11	CEMENTED 1	5% 10W
R6104	1-249-429-11	CARBON 10K	5% 1/4W
R6105	1-249-429-11	CARBON 10K	5% 1/4W
R6106	1-202-962-11	CEMENTED 3.3	5% 10W
R6107	1-202-962-11	CEMENTED 3.3	5% 10W
R6109	1-249-437-11	CARBON 47K	5% 1/4W
R6111	1-215-857-11	METAL OXIDE 10	5% 1W F
R6112	1-215-857-11	METAL OXIDE 10	5% 1W F

RELAY

RY6000 Δ	1-755-146-11	RELAY, AC POWER
RY6001 Δ	1-755-330-11	RELAY, AC POWER
RY6002 Δ	1-755-330-11	RELAY, AC POWER

TRANSFORMER

T6000 Δ	1-433-900-11	TRANSFORMER, LINE FILTER
T6001 Δ	1-433-900-11	TRANSFORMER, LINE FILTER
T6002 Δ	1-433-846-11	TRANSFORMER, CONVERTER (PIT)
T6003 Δ	1-433-844-11	TRANSFORMER, CONVERTER

THERMISTOR

TH6000 Δ	1-803-540-11	THERMISTOR
TH6001 Δ	1-803-629-11	THERMISTOR, POSITIVE
TH6002	1-803-586-11	THERMISTOR

VARISTOR

VD6000 Δ	1-803-587-11	VARISTOR
VD6002 Δ	1-803-614-11	VARISTOR

COMPLETE PARTS LISTING **HA** **HB** **HX**

REF.NO.	PART NO.	DESCRIPTION	REMARK		
HA					
* A-1372-634-A HA BOARD, COMPLETE (All Models)					
CAPACITOR					
C1234	1-126-960-11	ELECT	1µF	20%	50V
C1235	1-126-960-11	ELECT	1µF	20%	50V
C1239	1-216-295-91	SHORT			
CONNECTOR					
CN1232*1-564-512-11 PLUG, CONNECTOR 9P					
DIODE					
D1233	8-719-110-17	DIODE MTZJ-T-77-10B			
JACK					
J1231	1-770-361-11	TERMINAL BLOCK, S			
RESISTOR					
R201	1-216-049-91	RES, CHIP	1K	5%	1/10W
R202	1-216-055-00	RES, CHIP	1.8K	5%	1/10W
R203	1-216-065-91	RES, CHIP	4.7K	5%	1/10W
R1233	1-216-065-91	RES, CHIP	4.7K	5%	1/10W
R1235	1-216-065-91	RES, CHIP	4.7K	5%	1/10W
R1236	1-216-113-00	RES, CHIP	470K	5%	1/10W
R1237	1-216-065-91	RES, CHIP	4.7K	5%	1/10W
R1238	1-216-113-00	RES, CHIP	470K	5%	1/10W
SWITCH					
S2007	1-572-198-11	SWITCH, KEYBOARD			
S2008	1-572-198-11	SWITCH, KEYBOARD			
S2009	1-572-198-11	SWITCH, KEYBOARD			
S2010	1-572-198-11	SWITCH, KEYBOARD			

REF.NO.	PART NO.	DESCRIPTION	REMARK		
HB					
* A-1372-635-A HB BOARD, COMPLETE (All Models)					
CAPACITOR					
C2001	1-104-665-11	ELECT	100µF	20%	25V

REF.NO.	PART NO.	DESCRIPTION	REMARK		
CONNECTOR					
CN2001*1-564-520-11 PLUG, CONNECTOR 5P					
DIODE					
D2002	8-719-057-09	DIODE LNJ801LPDJA			
D2003	8-719-057-09	DIODE LNJ801LPDJA			
IC					
IC2001	8-742-088-10	HYB IC SBX1780-51			
RESISTOR					
R2001	1-216-049-91	RES, CHIP	1K	5%	1/10W
R2002	1-216-049-91	RES, CHIP	1K	5%	1/10W
R2003	1-216-017-91	RES, CHIP	47	5%	1/10W

REF.NO.	PART NO.	DESCRIPTION	REMARK		
HX					
* A-1372-636-A HX BOARD, COMPLETE (All Models)					
CONNECTOR					
CN2002*1-564-518-11 PLUG, CONNECTOR 3P					
RESISTOR					
R2010	1-216-047-91	RES, CHIP	820	5%	1/10W
R2011	1-216-049-91	RES, CHIP	1K	5%	1/10W
R2012	1-216-055-00	RES, CHIP	1.8K	5%	1/10W
R2013	1-216-065-91	RES, CHIP	4.7K	5%	1/10W
R2014	1-216-025-91	RES, CHIP	100	5%	1/10W
SWITCH					
S2001	1-572-198-11	SWITCH, KEYBOARD			
S2002	1-572-198-11	SWITCH, KEYBOARD			
S2003	1-572-198-11	SWITCH, KEYBOARD			
S2004	1-572-198-11	SWITCH, KEYBOARD			
S2005	1-572-198-11	SWITCH, KEYBOARD			
S2006	1-572-198-11	SWITCH, KEYBOARD			

**COMPLETE PARTS LISTING**

REF.NO.	PART NO.	DESCRIPTION	REMARK
---------	----------	-------------	--------



* A-1394-934-A T BOARD, COMPLETE
(KV32XBR250/34FX250C/36XBR250/38FX250/38FX250C/38FX250T only)

CAPACITOR

C401	1-163-243-11	CERAMIC CHIP	47pF	5%	50V
C402	1-163-035-00	CERAMIC CHIP	0.047μF		50V
C403	1-126-963-11	ELECT	4.7μF	20%	50V
C404	1-163-135-00	CERAMIC CHIP	560pF	5%	50V
C405	1-104-664-11	ELECT	47μF	20%	25V
C406	1-163-021-91	CERAMIC CHIP	0.01μF	10%	50V
C407	1-163-035-00	CERAMIC CHIP	0.047μF		50V
C408	1-163-135-00	CERAMIC CHIP	560pF	5%	50V
C409	1-126-963-11	ELECT	4.7μF	20%	50V
C410	1-163-243-11	CERAMIC CHIP	47pF	5%	50V
C411	1-126-963-11	ELECT	4.7μF	20%	50V
C412	1-164-161-11	CERAMIC CHIP	0.0022μF	10%	50V
C413	1-164-161-11	CERAMIC CHIP	0.0022μF	10%	50V
C414	1-104-664-11	ELECT	47μF	20%	25V
C415	1-163-021-91	CERAMIC CHIP	0.01μF	10%	50V
C416	1-104-664-11	ELECT	47μF	20%	25V
C417	1-126-963-11	ELECT	4.7μF	20%	50V
C418	1-163-229-11	CERAMIC CHIP	12pF	5%	50V
C419	1-163-227-11	CERAMIC CHIP	10pF	0.5pF	50V
C420	1-163-021-91	CERAMIC CHIP	0.01μF	10%	50V
C421	1-163-021-91	CERAMIC CHIP	0.01μF	10%	50V
C422	1-104-664-11	ELECT	47μF	20%	25V
C423	1-163-021-91	CERAMIC CHIP	0.01μF	10%	50V
C424	1-163-021-91	CERAMIC CHIP	0.01μF	10%	50V
C425	1-104-664-11	ELECT	47μF	20%	25V
C426	1-163-021-91	CERAMIC CHIP	0.01μF	10%	50V

CONNECTOR

CN401	*1-564-519-11	PLUG, CONNECTOR 4P			
-------	---------------	--------------------	--	--	--

DIODE

D401	8-719-109-89	DIODE RD5.6ESB2			
D402	8-719-057-93	DIODE SVC203SPA-AL			
D403	8-719-057-93	DIODE SVC203SPA-AL			
D404	8-719-992-13	DIODE DAL5815			
D405	8-719-992-13	DIODE DAL5815			
D406	8-719-992-13	DIODE DAL5815			
D407	8-719-992-13	DIODE DAL5815			
D408	8-719-992-13	DIODE DAL5815			
D409	8-719-992-13	DIODE DAL5815			
D410	8-719-992-13	DIODE DAL5815			
D411	8-719-992-13	DIODE DAL5815			

REF.NO.	PART NO.	DESCRIPTION	REMARK
---------	----------	-------------	--------

IC

IC401	8-759-939-73	IC BA3308	
-------	--------------	-----------	--

COIL

L401	1-411-987-11	COIL (OSC)	
L402	1-411-988-11	COIL (OSC)	

TRANSISTOR

Q401	8-729-266-83	TRANSISTOR 2SC2668-Y	
Q402	8-729-266-83	TRANSISTOR 2SC2668-Y	
Q403	8-729-119-78	TRANSISTOR 2SC3311A-QRSTA	
Q404	8-729-216-22	TRANSISTOR 2SB709A-QRS-TX	
Q405	8-729-216-22	TRANSISTOR 2SB709A-QRS-TX	
Q406	8-729-931-14	TRANSISTOR 2SD1858-Q-TV2	
Q407	8-729-931-14	TRANSISTOR 2SD1858-Q-TV2	
Q408	8-729-931-14	TRANSISTOR 2SD1858-Q-TV2	
Q409	8-729-931-14	TRANSISTOR 2SD1858-Q-TV2	
Q410	8-729-216-22	TRANSISTOR 2SB709A-QRS-TX	
Q411	8-729-216-22	TRANSISTOR 2SB709A-QRS-TX	

RESISTOR

R401	1-216-089-91	RES, CHIP	47K	5%	1/10W
R402	1-216-089-91	RES, CHIP	47K	5%	1/10W
R403	1-216-089-91	RES, CHIP	47K	5%	1/10W
R404	1-216-053-00	RES, CHIP	1.5K	5%	1/10W
R405	1-216-025-91	RES, CHIP	100	5%	1/10W
R406	1-216-053-00	RES, CHIP	1.5K	5%	1/10W
R407	1-216-133-00	RES, CHIP	3.3M	5%	1/10W
R408	1-216-089-91	RES, CHIP	47K	5%	1/10W
R409	1-216-053-00	RES, CHIP	1.5K	5%	1/10W
R410	1-216-053-00	RES, CHIP	1.5K	5%	1/10W
R411	1-216-025-91	RES, CHIP	100	5%	1/10W
R412	1-208-803-11	RES, CHIP	7.5K	0.50%	1/10W
R413	1-216-065-91	RES, CHIP	4.7K	5%	1/10W
R414	1-216-073-00	RES, CHIP	10K	5%	1/10W
R415	1-249-416-11	CARBON	820	5%	1/4W
R416	1-216-081-00	RES, CHIP	22K	5%	1/10W
R417	1-216-081-00	RES, CHIP	22K	5%	1/10W
R418	1-216-065-91	RES, CHIP	4.7K	5%	1/10W
R419	1-216-073-00	RES, CHIP	10K	5%	1/10W
R420	1-216-111-00	RES, CHIP	390K	5%	1/10W
R421	1-216-025-91	RES, CHIP	100	5%	1/10W
R422	1-216-025-91	RES, CHIP	100	5%	1/10W
R423	1-216-111-00	RES, CHIP	390K	5%	1/10W
R424	1-216-053-00	RES, CHIP	1.5K	5%	1/10W
R425	1-216-061-00	RES, CHIP	3.3K	5%	1/10W
R426	1-208-821-11	RES, CHIP	43K	0.50%	1/10W
R427	1-216-061-00	RES, CHIP	3.3K	5%	1/10W
R428	1-216-057-00	RES, CHIP	2.2K	5%	1/10W
R429	1-216-057-00	RES, CHIP	2.2K	5%	1/10W

COMPLETE PARTS LISTING



<u>REF.NO.</u>	<u>PART NO.</u>	<u>DESCRIPTION</u>	<u>REMARK</u>			<u>REF.NO.</u>	<u>PART NO.</u>	<u>DESCRIPTION</u>	<u>REMARK</u>
R430	1-208-794-11	RES, CHIP	3.3K	0.50%	1/10W				
R431	1-208-794-11	RES, CHIP	3.3K	0.50%	1/10W				
R432	1-208-821-11	RES, CHIP	43K	0.50%	1/10W				
R433	1-216-059-00	RES, CHIP	2.7K	5%	1/10W				
R434	1-216-059-00	RES, CHIP	2.7K	5%	1/10W				
R435	1-216-001-00	RES, CHIP	10	5%	1/10W				
R436	1-216-001-00	RES, CHIP	10	5%	1/10W				
R437	1-216-001-00	RES, CHIP	10	5%	1/10W				
R438	1-216-001-00	RES, CHIP	10	5%	1/10W				
R439	1-216-059-00	RES, CHIP	2.7K	5%	1/10W				
R460	1-216-059-00	RES, CHIP	2.7K	5%	1/10W				

UX COMPLETE PARTS LISTING

REF.NO.	PART NO.	DESCRIPTION	REMARK	REF.NO.	PART NO.	DESCRIPTION	REMARK
UX				C1212	1-126-933-11	ELECT	100µF 20% 16V
MAIN SCHEMATIC (FOR UX PIP COMPONENTS SEE PAGE 112)				C1213	1-126-941-11	ELECT	470µF 20% 25V
* A-1394-947-A UX BOARD, COMPLETE (KV-32XBR250/36XBR250 only)				C1214	1-163-021-91	CERAMIC	0.01µF 10% 50V
* A-1394-948-A UX BOARD, COMPLETE (KV-34FX250C/38FX250/38FX250C/38FX250T only)				C1215	1-126-960-11	ELECT	1µF 20% 50V
CAPACITOR				C2000	1-126-941-11	ELECT	470µF 20% 25V
C201	1-128-551-11	ELECT	22µF 20% 25V	C2001	1-163-235-11	CERAMIC	22pF 5% 50V
C202	1-128-551-11	ELECT	22µF 20% 25V	C2002	1-165-319-11	CERAMIC	0.1µF 50V
C203	1-128-551-11	ELECT	22µF 20% 25V	C2003	1-163-031-11	CERAMIC	0.01µF 50V
C204	1-126-960-11	ELECT	1µF 20% 50V	C2004	1-163-235-11	CERAMIC	22pF 5% 50V
C205	1-126-960-11	ELECT	1µF 20% 50V	C2005	1-163-131-00	CERAMIC	390pF 5% 50V
C231	1-163-021-91	CERAMIC	0.01µF 10% 50V	C2006	1-163-038-91	CERAMIC	0.1µF 25V
C232	1-126-933-11	ELECT	100µF 20% 16V	C2007	1-126-926-11	ELECT	1000µF 20% 10V
C233	1-126-933-11	ELECT	100µF 20% 16V	C2008	1-163-038-91	CERAMIC	0.1µF 25V
C234	1-126-960-11	ELECT	1µF 20% 50V	C2009	1-163-102-00	CERAMIC	24pF 5% 50V
C235	1-126-960-11	ELECT	1µF 20% 50V	C2012	1-163-031-11	CERAMIC	0.01µF 50V
C236	1-126-933-11	ELECT	100µF 20% 16V	C2013	1-163-038-91	CERAMIC	0.1µF 25V
C237	1-126-960-11	ELECT	1µF 20% 50V	C2014	1-163-009-11	CERAMIC	0.001µF 10% 50V
C238	1-126-960-11	ELECT	1µF 20% 50V	C2015	1-163-021-91	CERAMIC	0.01µF 10% 50V
C241	1-126-941-11	ELECT	470µF 20% 25V	C2016	1-165-319-11	CERAMIC	0.1µF 50V
C242	1-126-959-11	ELECT	0.47µF 20% 50V	C2017	1-163-102-00	CERAMIC	24pF 5% 50V
C243	1-126-959-11	ELECT	0.47µF 20% 50V	C2018	1-165-319-11	CERAMIC	0.1µF 50V
C244	1-126-959-11	ELECT	0.47µF 20% 50V	C2019	1-126-960-11	ELECT	1µF 20% 50V
C245	1-126-959-11	ELECT	0.47µF 20% 50V	C2020	1-165-319-11	CERAMIC	0.1µF 50V
C247	1-126-941-11	ELECT	470µF 20% 25V	C2021	1-163-038-91	CERAMIC	0.1µF 25V
C248	1-126-959-11	ELECT	0.47µF 20% 50V	C2022	1-126-933-11	ELECT	100µF 20% 16V
C249	1-126-959-11	ELECT	0.47µF 20% 50V	C2029	1-165-319-11	CERAMIC	0.1µF 50V
C264	1-164-004-11	CERAMIC	0.1µF 10% 25V	C2030	1-165-319-11	CERAMIC	0.1µF 50V
C268	1-163-021-91	CERAMIC	0.01µF 10% 50V	C2031	1-165-319-11	CERAMIC	0.1µF 50V
C269	1-163-021-91	CERAMIC	0.01µF 10% 50V	C2032	1-165-319-11	CERAMIC	0.1µF 50V
C272	1-163-231-11	CERAMIC	15pF 5% 50V	C2033	1-165-319-11	CERAMIC	0.1µF 50V
C273	1-128-551-11	ELECT	22µF 20% 25V	C2034	1-165-319-11	CERAMIC	0.1µF 50V
C277	1-128-551-11	ELECT	22µF 20% 25V	C2035	1-165-319-11	CERAMIC	0.1µF 50V
C278	1-128-551-11	ELECT	22µF 20% 25V	C2036	1-165-319-11	CERAMIC	0.1µF 50V
C281	1-126-933-11	ELECT	100µF 20% 16V	C2038	1-165-319-11	CERAMIC	0.1µF 50V
C284	1-126-941-11	ELECT	470µF 20% 25V	C2041	1-104-665-11	ELECT	100µF 20% 25V
C286	1-164-161-11	CERAMIC	0.0022µF 10% 50V	C2042	1-165-319-11	CERAMIC	0.1µF 50V
C287	1-164-161-11	CERAMIC	0.0022µF 10% 50V	C2044	1-104-664-11	ELECT	47µF 20% 16V
C1051	1-126-964-11	ELECT	10µF 20% 50V	C2045	1-163-233-11	CERAMIC	18pF 5% 50V
C1053	1-104-665-11	ELECT	100µF 20% 25V	C2046	1-126-964-11	ELECT	10µF 20% 50V
C1201	1-163-809-11	CERAMIC	0.047µF 10% 25V	C2047	1-126-961-11	ELECT	2.2µF 20% 50V
C1202	1-163-021-91	CERAMIC	0.01µF 10% 50V	C2048	1-126-964-11	ELECT	10µF 20% 50V
C1203	1-126-960-11	ELECT	1µF 20% 50V	C2050	1-163-231-11	CERAMIC	15pF 5% 50V
C1204	1-163-809-11	CERAMIC	0.047µF 10% 25V	C2051	1-126-964-11	ELECT	10µF 20% 50V
C1205	1-126-933-11	ELECT	100µF 20% 16V	C2052	1-163-133-00	CERAMIC	470pF 5% 50V
C1207	1-126-963-11	ELECT	4.7µF 20% 50V	C2053	1-126-960-11	ELECT	1µF 20% 50V
C1208	1-126-963-11	ELECT	4.7µF 20% 50V	C2054	1-104-664-11	ELECT	47µF 20% 16V
C1209	1-163-259-91	CERAMIC	220pF 5% 50V	C2057	1-163-031-11	CERAMIC	0.01µF 50V
C1210	1-163-259-91	CERAMIC	220pF 5% 50V	C2058	1-163-235-11	CERAMIC	22pF 5% 50V
C1211	1-126-933-11	ELECT	100µF 20% 16V	C2060	1-163-031-11	CERAMIC	0.01µF 50V
				C2062	1-104-664-11	ELECT	47µF 20% 16V
				C2063	1-165-319-11	CERAMIC	0.1µF 50V
				C2064	1-163-031-11	CERAMIC	0.01µF 50V
				C2065	1-163-031-11	CERAMIC	0.01µF 50V
				C2066	1-104-664-11	ELECT	47µF 20% 16V
				C2067	1-104-664-11	ELECT	47µF 20% 16V

UX COMPLETE PARTS LISTING

REF.NO.	PART NO.	DESCRIPTION	REMARK	REF.NO.	PART NO.	DESCRIPTION	REMARK
J903	1-764-143-11	JACK	3P	Q234	8-729-422-27	TRANSISTOR 2SD601A-Q	
J904	1-764-143-11	JACK	3P	Q235	8-729-422-27	TRANSISTOR 2SD601A-Q	
J905	1-764-143-11	JACK	3P	Q236	8-729-422-27	TRANSISTOR 2SD601A-Q	
CHIP CONDUCTOR				Q237	8-729-216-22	TRANSISTOR 2SA1162-G	
JR1001	1-216-295-91	SHORT		Q238	8-729-216-22	TRANSISTOR 2SA1162-G	
JR1002	1-216-295-91	SHORT		Q239	8-729-216-22	TRANSISTOR 2SA1162-G	
JR1003	1-216-295-91	SHORT		Q240	8-729-422-27	TRANSISTOR 2SD601A-Q	
JR1004	1-216-295-91	SHORT		Q241	8-729-422-27	TRANSISTOR 2SD601A-Q	
JR1021	1-216-295-91	SHORT		Q242	8-729-422-27	TRANSISTOR 2SD601A-Q	
JR1022	1-216-295-91	SHORT		Q243	8-729-216-22	TRANSISTOR 2SA1162-G	
JR1023	1-216-295-91	SHORT		Q244	8-729-216-22	TRANSISTOR 2SA1162-G	
JR2007	1-216-295-91	SHORT		Q245	8-729-216-22	TRANSISTOR 2SA1162-G	
JR2008	1-216-295-91	SHORT		Q246	8-729-422-27	TRANSISTOR 2SD601A-Q	
JR2009	1-216-295-91	SHORT		Q262	8-729-216-22	TRANSISTOR 2SA1162-G	
JR2010	1-216-295-91	SHORT		Q263	8-729-216-22	TRANSISTOR 2SA1162-G	
JR2011	1-216-295-91	SHORT		Q264	8-729-216-22	TRANSISTOR 2SA1162-G	
JR2012	1-216-295-91	SHORT		Q265	8-729-422-27	TRANSISTOR 2SD601A-Q	
JR2013	1-216-295-91	SHORT		Q267	8-729-216-22	TRANSISTOR 2SA1162-G	
JR2014	1-216-295-91	SHORT		Q268	8-729-216-22	TRANSISTOR 2SA1162-G	
COIL				Q1051	8-729-216-22	TRANSISTOR 2SA1162-G	
L261	1-414-857-11	INDUCTOR	100µH	Q1201	8-729-216-22	TRANSISTOR 2SA1162-G	
L1201	1-408-397-00	INDUCTOR	1µH	Q1202	8-729-422-27	TRANSISTOR 2SD601A-Q	
L1202	1-408-397-00	INDUCTOR	1µH	Q1203	8-729-422-27	TRANSISTOR 2SD601A-Q	
L1203	1-408-397-00	INDUCTOR	1µH	Q1204	8-729-216-22	TRANSISTOR 2SA1162-G	
L2001	1-410-466-41	INDUCTOR	4.7µH	Q1205	8-729-422-27	TRANSISTOR 2SD601A-Q	
L2002	1-414-856-11	INDUCTOR	10µH	Q1206	8-729-422-27	TRANSISTOR 2SD601A-Q	
L2003	1-414-856-11	INDUCTOR	10µH	Q1207	8-729-216-22	TRANSISTOR 2SA1162-G	
L2004	1-410-473-11	INDUCTOR	18µH	Q1208	8-729-216-22	TRANSISTOR 2SA1162-G	
L2006	1-414-856-11	INDUCTOR	10µH	Q1405	8-729-216-22	TRANSISTOR 2SA1162-G	
L2007	1-414-857-11	INDUCTOR	100µH	Q1406	8-729-216-22	TRANSISTOR 2SA1162-G	
L2008	1-414-856-11	INDUCTOR	10µH	Q2001	8-729-422-27	TRANSISTOR 2SD601A-Q	
L2009	1-414-856-11	INDUCTOR	10µH	Q2003	8-729-216-22	TRANSISTOR 2SA1162-G	
L2010	1-410-494-11	INDUCTOR	1mH	Q2004	8-729-216-22	TRANSISTOR 2SA1162-G	
L2011	1-410-116-11	INDUCTOR	560µH	Q2005	8-729-422-27	TRANSISTOR 2SD601A-Q	
L2012	1-410-116-11	INDUCTOR	560µH	Q2006	8-729-422-27	TRANSISTOR 2SD601A-Q	
L2013	1-410-462-11	INDUCTOR	2.2µH	Q2007	8-729-422-27	TRANSISTOR 2SD601A-Q	
L2014	1-410-462-11	INDUCTOR	2.2µH	Q2008	8-729-422-27	TRANSISTOR 2SD601A-Q	
TRANSISTOR				Q2009	8-729-422-27	TRANSISTOR 2SD601A-Q	
Q202	8-729-422-27	TRANSISTOR 2SD601A-Q		Q2010	8-729-422-27	TRANSISTOR 2SD601A-Q	
Q203	8-729-422-27	TRANSISTOR 2SD601A-Q		Q2011	8-729-422-27	TRANSISTOR 2SD601A-Q	
Q205	8-729-216-22	TRANSISTOR 2SA1162-G		Q2012	8-729-216-22	TRANSISTOR 2SA1162-G	
Q206	8-729-216-22	TRANSISTOR 2SA1162-G		Q2013	8-729-216-22	TRANSISTOR 2SA1162-G	
Q208	8-729-422-27	TRANSISTOR 2SD601A-Q		Q2014	8-729-422-27	TRANSISTOR 2SD601A-Q	
Q209	8-729-422-27	TRANSISTOR 2SD601A-Q		Q2015	8-729-422-27	TRANSISTOR 2SD601A-Q	
Q210	8-729-422-27	TRANSISTOR 2SD601A-Q		Q2016	8-729-422-27	TRANSISTOR 2SD601A-Q	
Q211	8-729-422-27	TRANSISTOR 2SD601A-Q		Q2017	8-729-422-27	TRANSISTOR 2SD601A-Q	
Q231	8-729-422-27	TRANSISTOR 2SD601A-Q		Q2018	8-729-216-22	TRANSISTOR 2SA1162-G	
Q233	8-729-422-27	TRANSISTOR 2SD601A-Q		Q2019	8-729-422-27	TRANSISTOR 2SD601A-Q	
				Q2119	8-729-216-22	TRANSISTOR 2SA1162-G	
				RESISTOR			
				R201	1-216-022-00	RES, CHIP	75 5% 1/10W
				R202	1-216-022-00	RES, CHIP	75 5% 1/10W
				R203	1-216-022-00	RES, CHIP	75 5% 1/10W



COMPLETE PARTS LISTING

REF.NO.	PART NO.	DESCRIPTION	REMARK	REF.NO.	PART NO.	DESCRIPTION	REMARK
R204	1-216-113-00	RES, CHIP	470K 5% 1/10W	R267	1-216-025-91	RES, CHIP	100 5% 1/10W
R205	1-216-113-00	RES, CHIP	470K 5% 1/10W	R268	1-216-067-00	RES, CHIP	5.6K 5% 1/10W
R206	1-216-295-91	SHORT		R269	1-216-067-00	RES, CHIP	5.6K 5% 1/10W
R207	1-216-295-91	SHORT		R270	1-216-049-91	RES, CHIP	1K 5% 1/10W
R208	1-216-295-91	SHORT		R271	1-216-067-00	RES, CHIP	5.6K 5% 1/10W
R209	1-216-089-91	RES, CHIP	47K 5% 1/10W	R272	1-216-025-91	RES, CHIP	100 5% 1/10W
R210	1-216-081-00	RES, CHIP	22K 5% 1/10W	R273	1-216-067-00	RES, CHIP	5.6K 5% 1/10W
R211	1-216-089-91	RES, CHIP	47K 5% 1/10W	R274	1-216-049-91	RES, CHIP	1K 5% 1/10W
R212	1-216-081-00	RES, CHIP	22K 5% 1/10W	R275	1-216-025-91	RES, CHIP	100 5% 1/10W
R213	1-216-089-91	RES, CHIP	47K 5% 1/10W	R276	1-216-295-91	SHORT	
R214	1-216-081-00	RES, CHIP	22K 5% 1/10W	R278	1-216-067-00	RES, CHIP	5.6K 5% 1/10W
R218	1-208-774-11	RES, CHIP	470 0.50% 1/10W	R279	1-216-025-91	RES, CHIP	100 5% 1/10W
R219	1-216-049-91	RES, CHIP	1K 5% 1/10W	R280	1-216-067-00	RES, CHIP	5.6K 5% 1/10W
R220	1-208-776-11	RES, CHIP	560 0.50% 1/10W	R281	1-216-025-91	RES, CHIP	100 5% 1/10W
R221	1-208-774-11	RES, CHIP	470 0.50% 1/10W	R282	1-216-025-91	RES, CHIP	100 5% 1/10W
R222	1-216-049-91	RES, CHIP	1K 5% 1/10W	R283	1-216-049-91	RES, CHIP	1K 5% 1/10W
R223	1-208-776-11	RES, CHIP	560 0.50% 1/10W	R284	1-216-033-00	RES, CHIP	220 5% 1/10W
R225	1-216-025-91	RES, CHIP	100 5% 1/10W	R285	1-216-033-00	RES, CHIP	220 5% 1/10W
R226	1-216-025-91	RES, CHIP	100 5% 1/10W	R286	1-216-067-00	RES, CHIP	5.6K 5% 1/10W
R228	1-216-049-91	RES, CHIP	1K 5% 1/10W	R287	1-216-025-91	RES, CHIP	100 5% 1/10W
R229	1-216-049-91	RES, CHIP	1K 5% 1/10W	R288	1-216-067-00	RES, CHIP	5.6K 5% 1/10W
R230	1-216-089-91	RES, CHIP	47K 5% 1/10W	R289	1-216-067-00	RES, CHIP	5.6K 5% 1/10W
R231	1-216-022-00	RES, CHIP	75 5% 1/10W	R290	1-216-025-91	RES, CHIP	100 5% 1/10W
R232	1-216-022-00	RES, CHIP	75 5% 1/10W	R291	1-216-067-00	RES, CHIP	5.6K 5% 1/10W
R233	1-216-065-91	RES, CHIP	4.7K 5% 1/10W	R293	1-216-025-91	RES, CHIP	100 5% 1/10W
R234	1-216-022-00	RES, CHIP	75 5% 1/10W	R294	1-216-077-00	RES, CHIP	15K 5% 1/10W
R235	1-216-113-00	RES, CHIP	470K 5% 1/10W	R295	1-216-025-91	RES, CHIP	100 5% 1/10W
R236	1-216-113-00	RES, CHIP	470K 5% 1/10W	R296	1-216-025-91	RES, CHIP	100 5% 1/10W
R237	1-216-022-00	RES, CHIP	75 5% 1/10W	R297	1-216-025-91	RES, CHIP	100 5% 1/10W
R238	1-216-113-00	RES, CHIP	470K 5% 1/10W	R300	1-216-025-91	RES, CHIP	100 5% 1/10W
R239	1-216-113-00	RES, CHIP	470K 5% 1/10W	R301	1-216-049-91	RES, CHIP	1K 5% 1/10W
R241	1-216-113-00	RES, CHIP	470K 5% 1/10W	R302	1-216-295-91	SHORT	
R242	1-216-049-91	RES, CHIP	1K 5% 1/10W	R902	1-249-405-11	CARBON	100 5% 1/4W F
R243	1-216-113-00	RES, CHIP	470K 5% 1/10W	R921	1-249-405-11	CARBON	100 5% 1/4W F
R244	1-216-049-91	RES, CHIP	1K 5% 1/10W	R923	1-249-405-11	CARBON	100 5% 1/4W F
R245	1-216-022-00	RES, CHIP	75 5% 1/10W	R925	1-249-405-11	CARBON	100 5% 1/4W F
R246	1-216-113-00	RES, CHIP	470K 5% 1/10W	R926	1-216-049-91	RES, CHIP	1K 5% 1/10W
R247	1-216-113-00	RES, CHIP	470K 5% 1/10W	R1051	1-216-073-00	RES, CHIP	10K 5% 1/10W
R248	1-216-113-00	RES, CHIP	470K 5% 1/10W	R1052	1-216-073-00	RES, CHIP	10K 5% 1/10W
R249	1-216-065-91	RES, CHIP	4.7K 5% 1/10W	R1054	1-216-025-91	RES, CHIP	100 5% 1/10W
R250	1-216-065-91	RES, CHIP	4.7K 5% 1/10W	R1055	1-216-073-00	RES, CHIP	10K 5% 1/10W
R251	1-216-065-91	RES, CHIP	4.7K 5% 1/10W	R1056	1-216-073-00	RES, CHIP	10K 5% 1/10W
R252	1-216-049-91	RES, CHIP	1K 5% 1/10W	R1057	1-216-025-91	RES, CHIP	100 5% 1/10W
R254	1-216-049-91	RES, CHIP	1K 5% 1/10W	R1058	1-216-025-91	RES, CHIP	100 5% 1/10W
R256	1-216-295-91	SHORT		R1059	1-216-065-91	RES, CHIP	4.7K 5% 1/10W
R257	1-216-049-91	RES, CHIP	1K 5% 1/10W	R1060	1-216-073-00	RES, CHIP	10K 5% 1/10W
R258	1-216-065-91	RES, CHIP	4.7K 5% 1/10W	R1062	1-216-025-91	RES, CHIP	100 5% 1/10W
R259	1-216-049-91	RES, CHIP	1K 5% 1/10W	R1063	1-216-073-00	RES, CHIP	10K 5% 1/10W
R260	1-216-065-91	RES, CHIP	4.7K 5% 1/10W	R1064	1-216-073-00	RES, CHIP	10K 5% 1/10W
R261	1-216-025-91	RES, CHIP	100 5% 1/10W	R1065	1-216-025-91	RES, CHIP	100 5% 1/10W
R262	1-216-067-00	RES, CHIP	5.6K 5% 1/10W	R1070	1-216-025-91	RES, CHIP	100 5% 1/10W
R263	1-216-025-91	RES, CHIP	100 5% 1/10W	R1201	1-216-025-91	RES, CHIP	100 5% 1/10W
R264	1-216-067-00	RES, CHIP	5.6K 5% 1/10W	R1202	1-216-025-91	RES, CHIP	100 5% 1/10W
R265	1-216-025-91	RES, CHIP	100 5% 1/10W	R1204	1-216-295-91	SHORT	
R266	1-216-025-91	RES, CHIP	100 5% 1/10W	R1206	1-216-295-91	SHORT	

COMPLETE PARTS LISTING

REF.NO.	PART NO.	DESCRIPTION	REMARK	REF.NO.	PART NO.	DESCRIPTION	REMARK
R1208	1-216-049-91	RES, CHIP	1K 5% 1/10W	R1272	1-216-655-11	RES, CHIP	1.5K 0.50% 1/10W
R1209	1-216-295-91	SHORT		R1273	1-208-788-11	RES, CHIP	1.8K 0.50% 1/10W
R1210	1-216-295-91	SHORT		R1274	1-216-049-91	RES, CHIP	1K 5% 1/10W
R1212	1-216-295-91	SHORT		R1276	1-216-049-91	RES, CHIP	1K 5% 1/10W
R1213	1-216-295-91	SHORT		R1277	1-216-025-91	RES, CHIP	100 5% 1/10W
R1214	1-216-295-91	SHORT		R1278	1-216-025-91	RES, CHIP	100 5% 1/10W
R1215	1-208-774-11	RES, CHIP	470 0.50% 1/10W	R1279	1-216-025-91	RES, CHIP	100 5% 1/10W
R1216	1-216-057-00	RES, CHIP	2.2K 5% 1/10W	R1280	1-216-025-91	RES, CHIP	100 5% 1/10W
R1217	1-216-091-00	RES, CHIP	56K 5% 1/10W	R1287	1-216-295-91	SHORT	
R1219	1-216-073-00	RES, CHIP	10K 5% 1/10W	R1288	1-216-295-91	SHORT	
R1220	1-216-013-00	RES, CHIP	33 5% 1/10W	R1289	1-216-295-91	SHORT	
R1221	1-216-121-91	RES, CHIP	1M 5% 1/10W	R1290	1-216-295-91	SHORT	
R1222	1-216-073-00	RES, CHIP	10K 5% 1/10W	R1291	1-216-295-91	SHORT	
R1223	1-216-097-91	RES, CHIP	100K 5% 1/10W	R1292	1-216-295-91	SHORT	
R1224	1-216-089-91	RES, CHIP	47K 5% 1/10W	R1293	1-216-049-91	RES, CHIP	1K 5% 1/10W
R1225	1-216-097-91	RES, CHIP	100K 5% 1/10W	R1294	1-216-049-91	RES, CHIP	1K 5% 1/10W
R1227	1-216-073-00	RES, CHIP	10K 5% 1/10W	R1295	1-216-049-91	RES, CHIP	1K 5% 1/10W
R1228	1-208-774-11	RES, CHIP	470 0.50% 1/10W	R1296	1-216-049-91	RES, CHIP	1K 5% 1/10W
R1229	1-216-121-91	RES, CHIP	1M 5% 1/10W	R1297	1-216-049-91	RES, CHIP	1K 5% 1/10W
R1230	1-216-073-00	RES, CHIP	10K 5% 1/10W	R1298	1-216-049-91	RES, CHIP	1K 5% 1/10W
R1231	1-216-295-91	SHORT		R1299	1-216-049-91	RES, CHIP	1K 5% 1/10W
R1233	1-216-097-91	RES, CHIP	100K 5% 1/10W	R1300	1-216-049-91	RES, CHIP	1K 5% 1/10W
R1234	1-216-091-00	RES, CHIP	56K 5% 1/10W	R1304	1-216-041-00	RES, CHIP	470 5% 1/10W
R1235	1-216-013-00	RES, CHIP	33 5% 1/10W	R1305	1-208-776-11	RES, CHIP	560 0.50% 1/10W
R1236	1-216-097-91	RES, CHIP	100K 5% 1/10W	R1306	1-216-025-91	RES, CHIP	100 5% 1/10W
R1237	1-216-089-91	RES, CHIP	47K 5% 1/10W	R1307	1-216-041-00	RES, CHIP	470 5% 1/10W
R1238	1-216-057-00	RES, CHIP	2.2K 5% 1/10W	R1308	1-208-776-11	RES, CHIP	560 0.50% 1/10W
R1240	1-216-295-91	SHORT		R1309	1-216-025-91	RES, CHIP	100 5% 1/10W
R1242	1-216-065-91	RES, CHIP	4.7K 5% 1/10W	R1422	1-216-065-91	RES, CHIP	4.7K 5% 1/10W
R1243	1-216-065-91	RES, CHIP	4.7K 5% 1/10W	R1423	1-216-065-91	RES, CHIP	4.7K 5% 1/10W
R1244	1-216-049-91	RES, CHIP	1K 5% 1/10W	R2001	1-216-073-00	RES, CHIP	10K 5% 1/10W
R1245	1-216-049-91	RES, CHIP	1K 5% 1/10W	R2002	1-216-073-00	RES, CHIP	10K 5% 1/10W
R1246	1-216-022-00	RES, CHIP	75 5% 1/10W	R2003	1-216-085-00	RES, CHIP	33K 5% 1/10W
R1247	1-216-113-00	RES, CHIP	470K 5% 1/10W	R2004	1-216-057-00	RES, CHIP	2.2K 5% 1/10W
R1248	1-216-113-00	RES, CHIP	470K 5% 1/10W	R2005	1-216-295-91	SHORT	
R1249	1-216-113-00	RES, CHIP	470K 5% 1/10W	R2006	1-216-065-91	RES, CHIP	4.7K 5% 1/10W
R1250	1-216-065-91	RES, CHIP	4.7K 5% 1/10W	R2008	1-216-025-91	RES, CHIP	100 5% 1/10W
R1251	1-216-049-91	RES, CHIP	1K 5% 1/10W	R2009	1-216-025-91	RES, CHIP	100 5% 1/10W
R1252	1-216-065-91	RES, CHIP	4.7K 5% 1/10W	R2010	1-216-001-00	RES, CHIP	10 5% 1/10W
R1254	1-216-049-91	RES, CHIP	1K 5% 1/10W	R2011	1-216-041-00	RES, CHIP	470 5% 1/10W
R1255	1-216-065-91	RES, CHIP	4.7K 5% 1/10W	R2012	1-216-025-91	RES, CHIP	100 5% 1/10W
R1256	1-216-065-91	RES, CHIP	4.7K 5% 1/10W	R2013	1-216-081-00	RES, CHIP	22K 5% 1/10W
R1257	1-216-065-91	RES, CHIP	4.7K 5% 1/10W	R2014	1-216-069-00	RES, CHIP	6.8K 5% 1/10W
R1258	1-216-049-91	RES, CHIP	1K 5% 1/10W	R2015	1-216-065-91	RES, CHIP	4.7K 5% 1/10W
R1259	1-216-049-91	RES, CHIP	1K 5% 1/10W	R2016	1-208-822-11	RES, CHIP	47K 0.50% 1/10W
R1260	1-216-295-91	SHORT		R2021	1-216-081-00	RES, CHIP	22K 5% 1/10W
R1263	1-216-295-91	SHORT		R2022	1-216-049-91	RES, CHIP	1K 5% 1/10W
R1264	1-216-049-91	RES, CHIP	1K 5% 1/10W	R2023	1-216-049-91	RES, CHIP	1K 5% 1/10W
R1265	1-216-001-00	RES, CHIP	10 5% 1/10W	R2027	1-216-049-91	RES, CHIP	1K 5% 1/10W
R1266	1-216-041-00	RES, CHIP	470 5% 1/10W	R2028	1-216-049-91	RES, CHIP	1K 5% 1/10W
R1267	1-216-025-91	RES, CHIP	100 5% 1/10W	R2029	1-216-043-91	RES, CHIP	560 5% 1/10W
R1268	1-216-049-91	RES, CHIP	1K 5% 1/10W	R2030	1-216-043-91	RES, CHIP	560 5% 1/10W
R1269	1-216-041-00	RES, CHIP	470 5% 1/10W	R2031	1-216-067-00	RES, CHIP	5.6K 5% 1/10W
R1270	1-216-049-91	RES, CHIP	1K 5% 1/10W	R2032	1-216-067-00	RES, CHIP	5.6K 5% 1/10W
R1271	1-216-001-00	RES, CHIP	10 5% 1/10W	R2033	1-216-057-00	RES, CHIP	2.2K 5% 1/10W



COMPLETE PARTS LISTING

REF.NO. PART NO. DESCRIPTION REMARK



PIP SCHEMATIC (FOR UX BOARD MAIN COMPONENTS SEE PAGE 106)

- * A-1394-947-A UX BOARD, COMPLETE
(KV-32XBR250/36XBR250 only)
- * A-1394-948-A UX BOARD, COMPLETE
(KV-34FX250C/38FX250/38FX250C/38FX250T only)

CAPACITOR

C3301	1-104-664-11	ELECT	47µF	20%	25V
C3302	1-163-021-91	CERAMIC	0.01µF	10%	50V
C3319	1-163-031-11	CERAMIC	0.01µF		50V
C3320	1-126-960-11	ELECT	1µF	20%	50V
C3321	1-163-231-11	CERAMIC	15pF	5%	50V
C3322	1-163-231-11	CERAMIC	15pF	5%	50V
C3323	1-163-031-11	CERAMIC	0.01µF		50V
C3324	1-126-926-11	ELECT	1000µF	20%	10V
C3325	1-126-926-11	ELECT	1000µF	20%	10V
C3328	1-126-925-11	ELECT	470µF	20%	10V
C3329	1-104-664-11	ELECT	47µF	20%	16V
C3330	1-163-031-11	CERAMIC	0.01µF		50V
C3331	1-104-664-11	ELECT	47µF	20%	16V
C3332	1-104-664-11	ELECT	47µF	20%	25V
C3334	1-163-031-11	CERAMIC	0.01µF		50V
C3340	1-163-031-11	CERAMIC	0.01µF		50V
C3342	1-163-009-11	CERAMIC	0.001µF	10%	50V
C3346	1-163-251-11	CERAMIC	100pF	5%	50V
C3347	1-126-960-11	ELECT	1µF	20%	50V
C3348	1-104-664-11	ELECT	47µF	20%	16V
C3349	1-163-249-11	CERAMIC	82pF	5%	50V
C3350	1-164-004-11	CERAMIC	0.1µF	10%	25V
C3352	1-163-031-11	CERAMIC	0.01µF		50V
C3353	1-126-960-11	ELECT	1µF	20%	50V
C3354	1-163-031-11	CERAMIC	0.01µF		50V
C3355	1-104-664-11	ELECT	47µF	20%	16V
C3356	1-163-038-91	CERAMIC	0.1µF		25V
C3357	1-163-038-91	CERAMIC	0.1µF		25V
C3358	1-163-038-91	CERAMIC	0.1µF		25V
C3359	1-163-038-91	CERAMIC	0.1µF		25V
C3360	1-163-038-91	CERAMIC	0.1µF		25V
C3361	1-163-038-91	CERAMIC	0.1µF		25V
C3362	1-104-664-11	ELECT	47µF	20%	16V
C3363	1-163-031-11	CERAMIC	0.01µF		50V
C3364	1-163-229-11	CERAMIC	12pF	5%	50V
C3365	1-163-133-00	CERAMIC	470pF	5%	50V
C3366	1-126-959-11	ELECT	0.47µF	20%	50V
C3367	1-126-963-11	ELECT	4.7µF	20%	50V
C3368	1-164-005-11	CERAMIC	0.47µF		25V
C3369	1-163-251-11	CERAMIC	100pF	5%	50V
C3370	1-126-960-11	ELECT	1µF	20%	50V
C3371	1-163-017-00	CERAMIC	0.0047µF	10%	50V

REF.NO. PART NO. DESCRIPTION REMARK

C3372	1-164-005-11	CERAMIC	0.47µF		25V
C3377	1-164-004-11	CERAMIC	0.1µF	10%	25V
		(KV-32XBR250/36XBR250 only)			
C3378	1-163-006-11	CERAMIC	560pF	10%	50V
		(KV-32XBR250/36XBR250 only)			
C3380	1-164-004-11	CERAMIC	0.1µF	10%	25V
		(KV-32XBR250/36XBR250 only)			
C3381	1-163-019-00	CERAMIC	0.0068µF	10%	50V
		(KV-32XBR250/36XBR250 only)			
C3382	1-164-344-11	CERAMIC	0.068µF	10%	25V
		(KV-32XBR250/36XBR250 only)			
C3383	1-126-956-91	ELECT	0.1µF	20%	50V
		(KV-32XBR250/36XBR250 only)			
C3385	1-126-941-11	ELECT	470µF	20%	25V

FERRITE BEAD

FB3301	1-414-234-22	INDUCTOR			
FB3302	1-414-234-22	INDUCTOR			

IC

IC3302	8-759-358-38	IC NJM78M05DLA(TE1)			
IC3303	8-759-533-89	IC SDA9288XE-GEG-B121			
IC3304	8-752-086-80	IC CXA2019AQ-T4			
IC3307	8-759-575-50	IC Z8613012SSC			
		(KV-32XBR250/36XBR250 only)			
IC3308	8-759-932-69	IC BU4053BCF-T2			

COIL

L3301	1-414-856-11	INDUCTOR	10µH		
L3302	1-410-473-11	INDUCTOR	18µH		
L3303	1-410-473-11	INDUCTOR	18µH		
L3305	1-408-619-31	INDUCTOR	220µH		
L3306	1-414-857-11	INDUCTOR	100µH		
L3307	1-414-856-11	INDUCTOR	10µH		

TRANSISTOR

Q3301	8-729-422-27	TRANSISTOR 2SD601A-Q			
Q3302	8-729-216-22	TRANSISTOR 2SA1162-G			
Q3305	8-729-216-22	TRANSISTOR 2SA1162-G			
Q3306	8-729-216-22	TRANSISTOR 2SA1162-G			
Q3307	8-729-216-22	TRANSISTOR 2SA1162-G			
Q3310	8-729-422-27	TRANSISTOR 2SD601A-Q			
Q3312	8-729-216-22	TRANSISTOR 2SA1162-G			
Q3314	8-729-216-22	TRANSISTOR 2SA1162-G			
Q3322	8-729-422-27	TRANSISTOR 2SD601A-Q			
		(KV-32XBR250/36XBR250 only)			
R3301	1-216-295-91	SHORT			
R3303	1-216-295-91	SHORT			
R3304	1-216-295-91	SHORT			

COMPLETE PARTS LISTING



REF.NO.	PART NO.	DESCRIPTION	REMARK	REF.NO.	PART NO.	DESCRIPTION	REMARK
R3305	1-216-043-91	RES, CHIP	560 5% 1/10W	R3394	1-216-041-00	RES, CHIP	470 5% 1/10W
R3306	1-216-295-91	SHORT				(KV-32XBR250/36XBR250 only)	
R3308	1-216-295-91	SHORT		R3395	1-216-061-00	RES, CHIP	3.3K 5% 1/10W
		(KV-32XBR250/36XBR250 only)		R3398	1-216-069-00	RES, CHIP	6.8K 5% 1/10W
R3309	1-216-041-00	RES, CHIP	470 5% 1/10W			(KV-32XBR250/36XBR250 only)	
R3312	1-216-037-00	RES, CHIP	330 5% 1/10W	R3399	1-216-025-91	RES, CHIP	100 5% 1/10W
R3313	1-216-295-91	SHORT				(KV-32XBR250/36XBR250 only)	
R3314	1-216-049-91	RES, CHIP	1K 5% 1/10W	R3401	1-216-025-91	RES, CHIP	100 5% 1/10W
R3320	1-216-295-91	SHORT				(KV-32XBR250/36XBR250 only)	
R3322	1-216-065-91	RES, CHIP	4.7K 5% 1/10W	R3402	1-216-025-91	RES, CHIP	100 5% 1/10W
						(KV-32XBR250/36XBR250 only)	
R3323	1-216-065-91	RES, CHIP	4.7K 5% 1/10W	R3404	1-216-073-00	RES, CHIP	10K 5% 1/10W
R3324	1-216-065-91	RES, CHIP	4.7K 5% 1/10W			(KV-32XBR250/36XBR250 only)	
R3325	1-216-025-91	RES, CHIP	100 5% 1/10W				
		(KV-32XBR250/36XBR250 only)					
R3326	1-216-295-91	SHORT					
R3329	1-216-069-00	RES, CHIP	6.8K 5% 1/10W				
R3332	1-216-033-00	RES, CHIP	220 5% 1/10W				
R3337	1-216-033-00	RES, CHIP	220 5% 1/10W				
R3338	1-216-033-00	RES, CHIP	220 5% 1/10W				
R3339	1-216-049-91	RES, CHIP	1K 5% 1/10W				
R3340	1-216-041-00	RES, CHIP	470 5% 1/10W				
R3341	1-216-057-00	RES, CHIP	2.2K 5% 1/10W				
R3342	1-216-057-00	RES, CHIP	2.2K 5% 1/10W				
R3343	1-216-049-91	RES, CHIP	1K 5% 1/10W				
R3346	1-216-049-91	RES, CHIP	1K 5% 1/10W				
R3350	1-216-295-91	SHORT					
R3351	1-216-295-91	SHORT					
R3352	1-216-049-91	RES, CHIP	1K 5% 1/10W				
R3355	1-216-295-91	SHORT					
R3357	1-216-295-91	SHORT					
R3358	1-216-047-91	RES, CHIP	820 5% 1/10W				
R3359	1-216-047-91	RES, CHIP	820 5% 1/10W				
R3360	1-216-053-00	RES, CHIP	1.5K 5% 1/10W				
R3361	1-216-045-00	RES, CHIP	680 5% 1/10W				
R3362	1-208-768-11	RES, CHIP	240 0.50% 1/10W				
R3363	1-208-766-11	RES, CHIP	220 0.50% 1/10W				
R3364	1-208-769-11	RES, CHIP	300 0.50% 1/10W				
R3370	1-216-295-91	SHORT					
R3375	1-216-041-00	RES, CHIP	470 5% 1/10W				
R3376	1-216-071-00	RES, CHIP	8.2K 5% 1/10W				
R3377	1-216-073-00	RES, CHIP	10K 5% 1/10W				
R3378	1-216-053-00	RES, CHIP	1.5K 5% 1/10W				
R3379	1-216-077-00	RES, CHIP	15K 5% 1/10W				
R3380	1-216-295-91	SHORT					
R3381	1-216-295-91	SHORT					
R3382	1-216-057-00	RES, CHIP	2.2K 5% 1/10W				
R3383	1-216-025-91	RES, CHIP	100 5% 1/10W				
R3384	1-216-033-00	RES, CHIP	220 5% 1/10W				
R3385	1-216-109-00	RES, CHIP	330K 5% 1/10W				
R3387	1-216-295-91	SHORT					
R3388	1-216-295-91	SHORT					
R3392	1-216-295-91	SHORT					
		(KV-32XBR250/36XBR250 only)					
R3393	1-216-025-91	RES, CHIP	100 5% 1/10W				
		(KV-32XBR250/36XBR250 only)					

CRYSTAL

X3302	1-760-095-21	VIBRATOR, CRYSTAL	
X3303	1-577-611-11	OSCILLATOR, CERAMIC	
X3304	1-567-505-11	OSCILLATOR, CRYSTAL	

UY COMPLETE PARTS LISTING

REF.NO.	PART NO.	DESCRIPTION	REMARK
UY			

MAIN SCHEMATIC (FOR UY PIP COMPONENTS SEE PAGE 119)

- * A-1394-938-A UY BOARD, COMPLETE
(KV-32FS10/34FV10/36FS10 only)
- * A-1394-943-A UY BOARD, COMPLETE
(KV-32FV15/36FV15 only)
- * A-1394-944-A UY BOARD, COMPLETE
(KV-34FV15/34FV15C/34FV15K/34FV15T/38FV15K only)

CAPACITOR

C201	1-128-551-11	ELECT	22µF	20%	25V
C202	1-128-551-11	ELECT	22µF	20%	25V
C203	1-128-551-11	ELECT	22µF	20%	25V
C204	1-126-960-11	ELECT	1µF	20%	50V
C205	1-126-960-11	ELECT	1µF	20%	50V
C231	1-163-021-91	CERAMIC	0.01µF	10%	50V
C232	1-126-933-11	ELECT	100µF	20%	16V
C233	1-126-933-11	ELECT	100µF	20%	16V
C234	1-126-960-11	ELECT	1µF	20%	50V
C235	1-126-960-11	ELECT	1µF	20%	50V
C236	1-126-933-11	ELECT	100µF	20%	16V
C237	1-126-9600-11	ELECT	1µF	20%	50V
C238	1-126-960-11	ELECT	1µF	20%	50V
C241	1-126-941-11	ELECT	470µF	20%	25V
C242	1-126-959-11	ELECT	0.47µF	20%	50V
C243	1-126-959-11	ELECT	0.47µF	20%	50V
C244	1-126-959-11	ELECT	0.47µF	20%	50V
C245	1-126-959-11	ELECT	0.47µF	20%	50V
C264	1-164-004-11	CERAMIC	0.1µF	10%	25V
C268	1-163-021-91	CERAMIC	0.01µF	10%	50V
C269	1-163-021-91	CERAMIC	0.01µF	10%	50V
C272	1-163-231-11	CERAMIC	15pF	5%	50V
C273	1-128-551-11	ELECT	22µF	20%	25V
C277	1-128-551-11	ELECT	22µF	20%	25V
C278	1-128-551-11	ELECT	22µF	20%	25V
(KV-32FV15/36FV15/34FV15/34FV15C/34FV15K/34FV15T/38FV15K only)					
C279	1-163-021-91	CERAMIC	0.01µF	10%	50V
C281	1-126-933-11	ELECT	100µF	20%	16V
C284	1-126-941-11	ELECT	470µF	20%	25V
C286	1-164-161-11	CERAMIC	0.0022µF	10%	50V
C287	1-164-161-11	CERAMIC	0.0022µF	10%	50V
C1051	1-126-964-11	ELECT	10µF	20%	50V
C1053	1-104-665-11	ELECT	100µF	20%	25V
C1201	1-163-809-11	CERAMIC	0.047µF	10%	25V
C1202	1-163-021-91	CERAMIC	0.01µF	10%	50V
C1203	1-126-960-11	ELECT	1µF	20%	50V
C1204	1-163-809-11	CERAMIC	0.047µF	10%	25V
C1209	1-163-259-91	CERAMIC	220pF	5%	50V
C1210	1-163-259-91	CERAMIC	220pF	5%	50V
C1211	1-126-933-11	ELECT	100µF	20%	16V
C1212	1-126-933-11	ELECT	100µF	20%	16V

REF.NO.	PART NO.	DESCRIPTION	REMARK
C1213	1-126-941-11	ELECT	470µF 20% 25V
C1214	1-163-021-91	CERAMIC	0.01µF 10% 50V
C1215	1-126-960-11	ELECT	1µF 20% 50V
C2000	1-126-941-11	ELECT	470µF 20% 25V
C2002	1-126-933-11	ELECT	100µF 20% 16V
C2007	1-104-665-11	ELECT	100µF 20% 10V
C2008	1-163-038-91	CERAMIC	0.1µF 25V
C2012	1-163-021-91	CERAMIC	0.01µF 10% 50V
C2015	1-163-021-91	CERAMIC	0.01µF 10% 50V
C2045	1-163-237-11	CERAMIC	27pF 5% 50V
C2047	1-126-961-11	ELECT	2.2µF 20% 50V
C2048	1-126-964-11	ELECT	10µF 20% 50V
C2049	1-104-664-11	ELECT	47µF 20% 16V
C2056	1-163-231-11	CERAMIC	15pF 5% 50V
C2060	1-163-031-11	CERAMIC	0.01µF 50V
C2062	1-104-664-11	ELECT	47µF 20% 16V
C2096	1-163-231-11	CERAMIC	15pF 5% 50V
C2097	1-163-231-11	CERAMIC	15pF 5% 50V
C2201	1-126-965-11	ELECT	22µF 20% 50V
C2202	1-126-933-11	ELECT	100µF 20% 16V
C2203	1-163-021-91	CERAMIC	0.01µF 10% 50V
C3556	1-163-038-91	CERAMIC	0.1µF 25V
C3557	1-163-021-91	CERAMIC	0.01µF 10% 50V
C3558	1-126-964-11	ELECT	10µF 20% 50V
C3559	1-163-038-91	CERAMIC	0.1µF 25V
C3560	1-163-038-91	CERAMIC	0.1µF 25V
C3561	1-126-964-11	ELECT	10µF 20% 50V
C3562	1-163-038-91	CERAMIC	0.1µF 25V
C3563	1-163-038-91	CERAMIC	0.1µF 25V
C3564	1-163-038-91	CERAMIC	0.1µF 25V
C3565	1-163-038-91	CERAMIC	0.1µF 25V
C3566	1-126-964-11	ELECT	10µF 20% 50V
C3567	1-163-021-91	CERAMIC	0.01µF 10% 50V
C3568	1-163-021-91	CERAMIC	0.01µF 10% 50V
C3569	1-126-964-11	ELECT	10µF 20% 50V
C3570	1-126-964-11	ELECT	10µF 20% 50V
C3571	1-163-021-91	CERAMIC	0.01µF 10% 50V
C3573	1-163-037-11	CERAMIC	0.022µF 10% 50V
C3574	1-163-021-91	CERAMIC	0.01µF 10% 50V
C3575	1-126-964-11	ELECT	10µF 20% 50V
C3576	1-163-021-91	CERAMIC	0.01µF 10% 50V
C3577	1-126-964-11	ELECT	10µF 20% 50V
C3578	1-163-021-91	CERAMIC	0.01µF 10% 50V
C3579	1-104-664-11	ELECT	47µF 20% 16V

CONNECTOR

CN261	1-564-510-11	PLUG, CONNECTOR	7P
(KV-32FV15/36FV15/34FV15/34FV15C/34FV15K/34FV15T/38FV15K only)			
CN262	1-691-632-21	CONNECTOR, BOARD TO BOARD	
CN263	1-691-632-21	CONNECTOR, BOARD TO BOARD	15P
(KV-32FV15/36FV15/34FV15/34FV15C/34FV15K/34FV15T/38FV15K only)			
CN264	1-691-632-21	CONNECTOR, BOARD TO BOARD	
CN265	1-564-513-11	PLUG, CONNECTOR	10P

COMPLETE PARTS LISTING



REF.NO.	PART NO.	DESCRIPTION	REMARK	REF.NO.	PART NO.	DESCRIPTION	REMARK
DIODE							
D201	8-719-032-47	DIODE MTZJ-T-9110		J902	1-764-143-11	JACK	3P
D202	8-719-032-47	DIODE MTZJ-T-9110		J903	1-764-143-11	JACK	3P
D203	8-719-032-47	DIODE MTZJ-T-9110		J904	1-764-143-11	JACK	3P
D204	8-719-032-47	DIODE MTZJ-T-9110		J905	1-764-143-11	JACK	3P
D205	8-719-032-47	DIODE MTZJ-T-9110		(KV-32FV15/36FV15/34FV15/34FV15C/34FV15K/34FV15T/38FV15K only)			
				CHIP CONDUCTOR			
D231	8-719-032-47	DIODE MTZJ-T-9110		JR1001	1-216-295-91	SHORT	
D232	8-719-032-47	DIODE MTZJ-T-9110		JR1002	1-216-295-91	SHORT	
D233	8-719-032-47	DIODE MTZJ-T-9110		JR1003	1-216-295-91	SHORT	
D234	8-719-032-47	DIODE MTZJ-T-9110		JR1004	1-216-295-91	SHORT	
D235	8-719-032-47	DIODE MTZJ-T-9110		JR1009	1-216-295-91	SHORT	
D236	8-719-032-47	DIODE MTZJ-T-9110		(KV-32FS10/34FV10/36FS10 only)			
D237	8-719-032-47	DIODE MTZJ-T-9110		JR1014	1-216-295-91	SHORT	
D238	8-719-032-47	DIODE MTZJ-T-9110		JR1015	1-216-295-91	SHORT	
D239	8-719-032-47	DIODE MTZJ-T-9110		JR1016	1-216-295-91	SHORT	
D245	8-719-157-94	DIODE RD3.3SB		JR1017	1-216-295-91	SHORT	
D246	8-719-157-94	DIODE RD3.3SB		JR1018	1-216-295-91	SHORT	
D247	8-719-157-94	DIODE RD3.3SB		JR1019	1-216-295-91	SHORT	
D248	8-719-157-94	DIODE RD3.3SB		JR1020	1-216-295-91	SHORT	
D250	8-719-157-94	DIODE RD3.3SB		JR1021	1-216-295-91	SHORT	
D261	8-719-032-47	DIODE MTZJ-T-9110		JR1022	1-216-295-91	SHORT	
D902	8-719-032-47	DIODE MTZJ-T-9110		JR1023	1-216-295-91	SHORT	
D910	8-719-032-47	DIODE MTZJ-T-9110					
D911	8-719-032-47	DIODE MTZJ-T-9110		COIL			
D912	8-719-032-47	DIODE MTZJ-T-9110		L261	1-414-857-11	INDUCTOR	100µH
(KV-32FV15/36FV15/34FV15/34FV15C/34FV15K/34FV15T/38FV15K only)				L1201	1-408-397-00	INDUCTOR	1µH
D1051	8-719-073-01	DIODE MA111-TX		L1202	1-408-397-00	INDUCTOR	1µH
D1052	8-719-073-01	DIODE MA111-TX		L2004	1-414-856-11	INDUCTOR	10µH
D2201	8-719-032-47	DIODE MTZJ-T-9110		L2005	1-410-494-11	INDUCTOR	1mH
D2202	8-719-032-47	DIODE MTZJ-T-9110		L2009	1-414-856-11	INDUCTOR	10µH
D2203	8-719-032-47	DIODE MTZJ-T-9110		L3581	1-408-397-00	INDUCTOR	1µH
				L3582	1-408-397-00	INDUCTOR	1µH
FILTER				TRANSISTOR			
FL2001	1-239-847-11	FILTER, LOW PASS		Q202	8-729-422-27	TRANSISTOR 2SD601A-Q	
FL2002	1-239-847-11	FILTER, LOW PASS		Q203	8-729-422-27	TRANSISTOR 2SD601A-Q	
FL2004	1-239-847-11	FILTER, LOW PASS		Q205	8-729-216-22	TRANSISTOR 2SA1162-G	
				Q206	8-729-216-22	TRANSISTOR 2SA1162-G	
				Q208	8-729-422-27	TRANSISTOR 2SD601A-Q	
				Q209	8-729-422-27	TRANSISTOR 2SD601A-Q	
				(KV-32FV15/36FV15/34FV15/34FV15C/34FV15K/34FV15T/38FV15K only)			
IC				Q210	8-729-422-27	TRANSISTOR 2SD601A-Q	
IC261	8-752-066-69	IC CXA1845Q		Q211	8-729-422-27	TRANSISTOR 2SD601A-Q	
IC1051	8-752-058-68	IC CXA1315M		Q212	8-729-422-27	TRANSISTOR 2SD601A-Q	
IC2006	8-759-358-38	IC NJM78M05DLA(TE1)		Q231	8-729-422-27	TRANSISTOR 2SD601A-Q	
IC3504	8-752-390-37	IC CXD2064Q-T6					
				Q233	8-729-422-27	TRANSISTOR 2SD601A-Q	
JACK				Q234	8-729-422-27	TRANSISTOR 2SD601A-Q	
J231	1-750-515-11	TERMINAL BLOCK, S 3P		Q235	8-729-422-27	TRANSISTOR 2SD601A-Q	
J232	1-750-517-11	JACK BLOCK, PIN	3P	Q236	8-729-422-27	TRANSISTOR 2SD601A-Q	
J233	1-750-516-11	JACK BLOCK, PIN	2P	Q237	8-729-216-22	TRANSISTOR 2SA1162-G	
J234	1-750-517-11	JACK BLOCK, PIN	3P				
J236	1-774-358-11	JACK BLOCK, PIN					

UY COMPLETE PARTS LISTING

REF.NO.	PART NO.	DESCRIPTION	REMARK	REF.NO.	PART NO.	DESCRIPTION	REMARK
Q238	8-729-216-22	TRANSISTOR 2SA1162-G		R222	1-216-049-91	RES, CHIP	1K 5% 1/10W
Q239	8-729-216-22	TRANSISTOR 2SA1162-G		R223	1-208-776-11	RES, CHIP	560 0.50% 1/10W
Q246	8-729-422-27	TRANSISTOR 2SD601A-Q		R225	1-216-025-91	RES, CHIP	100 5% 1/10W
Q262	8-729-216-22	TRANSISTOR 2SA1162-G		R226	1-216-025-91	RES, CHIP	100 5% 1/10W
Q263	8-729-216-22	TRANSISTOR 2SA1162-G		R228	1-216-049-91	RES, CHIP	1K 5% 1/10W
Q264	8-729-216-22	TRANSISTOR 2SA1162-G		R229	1-216-049-91	RES, CHIP	1K 5% 1/10W
Q265	8-729-422-27	TRANSISTOR 2SD601A-Q		(KV-32FV15/36FV1534FV15/34FV15C/34FV15K/34FV15T/38FV15K only)			
Q267	8-729-216-22	TRANSISTOR 2SA1162-G		R230	1-216-089-91	RES, CHIP	47K 5% 1/10W
Q1051	8-729-216-22	TRANSISTOR 2SA1162-G		R231	1-216-022-00	RES, CHIP	75 5% 1/10W
(KV-32FS10/34FV10/36FS10/34FV15/34FV15C/34FV15K/34FV15T/38FV15K only)				R232	1-216-022-00	RES, CHIP	75 5% 1/10W
Q1201	8-729-216-22	TRANSISTOR 2SA1162-G		R233	1-216-065-91	RES, CHIP	4.7K 5% 1/10W
Q1202	8-729-422-27	TRANSISTOR 2SD601A-Q		R234	1-216-022-00	RES, CHIP	75 5% 1/10W
Q1203	8-729-422-27	TRANSISTOR 2SD601A-Q		R235	1-216-113-00	RES, CHIP	470K 5% 1/10W
Q1204	8-729-216-22	TRANSISTOR 2SA1162-G		R236	1-216-113-00	RES, CHIP	470K 5% 1/10W
Q1205	8-729-422-27	TRANSISTOR 2SD601A-Q		R237	1-216-022-00	RES, CHIP	75 5% 1/10W
(KV-32FS10/34FV10/36FS10/34FV15/34FV15C/34FV15K/34FV15T/38FV15K only)				R238	1-216-113-00	RES, CHIP	470K 5% 1/10W
Q1206	8-729-422-27	TRANSISTOR 2SD601A-Q		R239	1-216-113-00	RES, CHIP	470K 5% 1/10W
Q1207	8-729-216-22	TRANSISTOR 2SA1162-G		R241	1-216-113-00	RES, CHIP	470K 5% 1/10W
Q1208	8-729-216-22	TRANSISTOR 2SA1162-G		R242	1-216-049-91	RES, CHIP	1K 5% 1/10W
Q2003	8-729-216-22	TRANSISTOR 2SA1162-G		R243	1-216-113-00	RES, CHIP	470K 5% 1/10W
Q2004	8-729-216-22	TRANSISTOR 2SA1162-G		R244	1-216-049-91	RES, CHIP	1K 5% 1/10W
Q2005	8-729-422-27	TRANSISTOR 2SD601A-Q		R245	1-216-022-00	RES, CHIP	75 5% 1/10W
Q2006	8-729-422-27	TRANSISTOR 2SD601A-Q		R246	1-216-113-00	RES, CHIP	470K 5% 1/10W
Q2007	8-729-422-27	TRANSISTOR 2SD601A-Q		R247	1-216-113-00	RES, CHIP	470K 5% 1/10W
Q2008	8-729-422-27	TRANSISTOR 2SD601A-Q		R248	1-216-113-00	RES, CHIP	470K 5% 1/10W
Q2009	8-729-422-27	TRANSISTOR 2SD601A-Q		R249	1-216-065-91	RES, CHIP	4.7K 5% 1/10W
Q2010	8-729-422-27	TRANSISTOR 2SD601A-Q		R250	1-216-065-91	RES, CHIP	4.7K 5% 1/10W
Q2014	8-729-422-27	TRANSISTOR 2SD601A-Q		R251	1-216-065-91	RES, CHIP	4.7K 5% 1/10W
Q2018	8-729-216-22	TRANSISTOR 2SA1162-G		R252	1-216-049-91	RES, CHIP	1K 5% 1/10W
Q2019	8-729-422-27	TRANSISTOR 2SD601A-Q		R254	1-216-049-91	RES, CHIP	1K 5% 1/10W
				R256	1-216-295-91	SHORT	
				R257	1-216-049-91	RES, CHIP	1K 5% 1/10W
				R258	1-216-025-91	RES, CHIP	100 5% 1/10W
				R259	1-216-049-91	RES, CHIP	1K 5% 1/10W
				R260	1-216-025-91	RES, CHIP	100 5% 1/10W
				R261	1-216-025-91	RES, CHIP	100 5% 1/10W
				R262	1-216-067-00	RES, CHIP	5.6K 5% 1/10W
				R263	1-216-025-91	RES, CHIP	100 5% 1/10W
				R264	1-216-067-00	RES, CHIP	5.6K 5% 1/10W
				R265	1-216-025-91	RES, CHIP	100 5% 1/10W
				R266	1-216-025-91	RES, CHIP	100 5% 1/10W
				R267	1-216-025-91	RES, CHIP	100 5% 1/10W
				R268	1-216-067-00	RES, CHIP	5.6K 5% 1/10W
				R269	1-216-067-00	RES, CHIP	5.6K 5% 1/10W
				R270	1-216-049-91	RES, CHIP	1K 5% 1/10W
				R271	1-216-067-00	RES, CHIP	5.6K 5% 1/10W
				R272	1-216-025-91	RES, CHIP	100 5% 1/10W
				R273	1-216-067-00	RES, CHIP	5.6K 5% 1/10W
				R274	1-216-049-91	RES, CHIP	1K 5% 1/10W
				R275	1-216-025-91	RES, CHIP	100 5% 1/10W
				R276	1-216-295-91	SHORT	
				R278	1-216-067-00	RES, CHIP	5.6K 5% 1/10W
				R279	1-216-025-91	RES, CHIP	100 5% 1/10W
				R280	1-216-067-00	RES, CHIP	5.6K 5% 1/10W

RESISTOR

R201	1-216-022-00	RES, CHIP	75	5%	1/10W
R202	1-216-022-00	RES, CHIP	75	5%	1/10W
R203	1-216-022-00	RES, CHIP	75	5%	1/10W
R204	1-216-113-00	RES, CHIP	470K	5%	1/10W
R205	1-216-113-00	RES, CHIP	470K	5%	1/10W

R206	1-216-295-91	SHORT			
R207	1-216-295-91	SHORT			
R208	1-216-295-91	SHORT			

R209	1-216-089-91	RES, CHIP	47K	5%	1/10W
R210	1-216-081-00	RES, CHIP	22K	5%	1/10W
R211	1-216-089-91	RES, CHIP	47K	5%	1/10W
R212	1-216-081-00	RES, CHIP	22K	5%	1/10W
R213	1-216-089-91	RES, CHIP	47K	5%	1/10W
(KV-32FV15/36FV1534FV15/34FV15C/34FV15K/34FV15T/38FV15K only)					

R214	1-216-081-00	RES, CHIP	22K	5%	1/10W
R218	1-208-774-11	RES, CHIP	470	0.50%	1/10W
R219	1-216-049-91	RES, CHIP	1K	5%	1/10W
R220	1-208-776-11	RES, CHIP	560	0.50%	1/10W
R221	1-208-774-11	RES, CHIP	470	0.50%	1/10W
(KV-32FV15/36FV1534FV15/34FV15C/34FV15K/34FV15T/38FV15K only)					

COMPLETE PARTS LISTING **UY**

REF.NO.	PART NO.	DESCRIPTION		REMARK		REF.NO.	PART NO.	DESCRIPTION		REMARK
R281	1-216-025-91	RES, CHIP	100	5%	1/10W	R1227	1-216-073-00	RES, CHIP	10K	5% 1/10W
R282	1-216-025-91	RES, CHIP	100	5%	1/10W	R1228	1-208-774-11	RES, CHIP	470	0.50% 1/10W
R283	1-216-049-91	RES, CHIP	1K	5%	1/10W	R1229	1-216-121-91	RES, CHIP	1M	5% 1/10W
R284	1-216-033-00	RES, CHIP	220	5%	1/10W	R1230	1-216-073-00	RES, CHIP	10K	5% 1/10W
R285	1-216-033-00	RES, CHIP	220	5%	1/10W	R1231	1-216-295-91	SHORT		
R286	1-216-067-00	RES, CHIP	5.6K	5%	1/10W	R1233	1-216-097-91	RES, CHIP	100K	5% 1/10W
R287	1-216-025-91	RES, CHIP	100	5%	1/10W	R1234	1-216-091-00	RES, CHIP	56K	5% 1/10W
R288	1-216-067-00	RES, CHIP	5.6K	5%	1/10W	R1235	1-216-013-00	RES, CHIP	33	5% 1/10W
R289	1-216-067-00	RES, CHIP	5.6K	5%	1/10W	R1236	1-216-097-91	RES, CHIP	100K	5% 1/10W
R290	1-216-025-91	RES, CHIP	100	5%	1/10W	R1237	1-216-089-91	RES, CHIP	47K	5% 1/10W
(KV-32FV15/36FV1534FV15/34FV15C/34FV15K/34FV15T/38FV15K only)						R1238	1-216-057-00	RES, CHIP	2.2K	5% 1/10W
R291	1-216-067-00	RES, CHIP	5.6K	5%	1/10W	R1239	1-208-774-11	RES, CHIP	470	0.50% 1/10W
R292	1-216-295-91	SHORT				R1242	1-216-065-91	RES, CHIP	4.7K	5% 1/10W
R293	1-216-025-91	RES, CHIP	100	5%	1/10W	R1243	1-216-065-91	RES, CHIP	4.7K	5% 1/10W
R294	1-216-077-00	RES, CHIP	15K	5%	1/10W	R1244	1-216-049-91	RES, CHIP	1K	5% 1/10W
R295	1-216-025-91	RES, CHIP	100	5%	1/10W	R1245	1-216-049-91	RES, CHIP	1K	5% 1/10W
R296	1-216-025-91	RES, CHIP	100	5%	1/10W	R1260	1-216-295-91	SHORT		
R297	1-216-025-91	RES, CHIP	100	5%	1/10W	R1263	1-216-295-91	SHORT		
R298	1-216-295-91	SHORT				R1264	1-216-049-91	RES, CHIP	1K	5% 1/10W
R300	1-216-025-91	RES, CHIP	100	5%	1/10W	R1265	1-216-001-00	RES, CHIP	10	5% 1/10W
R301	1-216-049-91	RES, CHIP	1K	5%	1/10W	R1266	1-216-041-00	RES, CHIP	470	5% 1/10W
R302	1-216-295-91	SHORT				(KV-32FV15/36FV1534FV15/34FV15C/34FV15K/34FV15T/38FV15K only)				
R902	1-249-405-11	CARBON	100	5%	1/4W	R1267	1-216-025-91	RES, CHIP	100	5% 1/10W
R921	1-249-405-11	CARBON	100	5%	1/4W	R1268	1-216-049-91	RES, CHIP	1K	5% 1/10W
R923	1-249-405-11	CARBON	100	5%	1/4W	R1269	1-216-041-00	RES, CHIP	470	5% 1/10W
R925	1-249-405-11	CARBON	100	5%	1/4W	(KV-32FV15/36FV1534FV15/34FV15C/34FV15K/34FV15T/38FV15K only)				
(KV-32FV15/36FV1534FV15/34FV15C/34FV15K/34FV15T/38FV15K only)						R1270	1-216-049-91	RES, CHIP	1K	5% 1/10W
R926	1-216-049-91	RES, CHIP	1K	5%	1/10W	R1271	1-216-001-00	RES, CHIP	10	5% 1/10W
R1055	1-216-073-00	RES, CHIP	10K	5%	1/10W	R1272	1-216-655-11	RES, CHIP	1.5K	0.50% 1/10W
R1056	1-216-073-00	RES, CHIP	10K	5%	1/10W	R1273	1-208-788-11	RES, CHIP	1.8K	0.50% 1/10W
R1057	1-216-025-91	RES, CHIP	100	5%	1/10W	R1274	1-216-049-91	RES, CHIP	1K	5% 1/10W
R1058	1-216-025-91	RES, CHIP	100	5%	1/10W	R1276	1-216-049-91	RES, CHIP	1K	5% 1/10W
R1059	1-216-065-91	RES, CHIP	4.7K	5%	1/10W	R1277	1-216-025-91	RES, CHIP	100	5% 1/10W
R1060	1-216-073-00	RES, CHIP	10K	5%	1/10W	(KV-32FV15/36FV1534FV15/34FV15C/34FV15K/34FV15T/38FV15K only)				
R1062	1-216-025-91	RES, CHIP	100	5%	1/10W	R1279	1-216-025-91	RES, CHIP	100	5% 1/10W
R1063	1-216-073-00	RES, CHIP	10K	5%	1/10W	R1284	1-216-295-91	SHORT		
R1064	1-216-073-00	RES, CHIP	10K	5%	1/10W	R1287	1-216-295-91	SHORT		
R1065	1-216-025-91	RES, CHIP	100	5%	1/10W	R1288	1-216-295-91	SHORT		
R1070	1-216-025-91	RES, CHIP	100	5%	1/10W	R1289	1-216-295-91	SHORT		
R1205	1-216-295-91	SHORT				R1290	1-216-295-91	SHORT		
R1207	1-208-774-11	RES, CHIP	470	0.50%	1/10W	R1291	1-216-295-91	SHORT		
R1209	1-216-295-91	SHORT				R1292	1-216-295-91	SHORT		
R1210	1-216-295-91	SHORT				R1293	1-216-049-91	RES, CHIP	1K	5% 1/10W
R1215	1-208-774-11	RES, CHIP	470	0.50%	1/10W	R1294	1-216-049-91	RES, CHIP	1K	5% 1/10W
R1216	1-216-057-00	RES, CHIP	2.2K	5%	1/10W	R1295	1-216-049-91	RES, CHIP	1K	5% 1/10W
R1217	1-216-091-00	RES, CHIP	56K	5%	1/10W	R1300	1-216-049-91	RES, CHIP	1K	5% 1/10W
R1218	1-216-295-91	SHORT				R1304	1-216-041-00	RES, CHIP	470	5% 1/10W
R1219	1-216-073-00	RES, CHIP	10K	5%	1/10W	R1305	1-208-776-11	RES, CHIP	560	0.50% 1/10W
R1220	1-216-013-00	RES, CHIP	33	5%	1/10W	R1306	1-216-025-91	RES, CHIP	100	5% 1/10W
R1221	1-216-121-91	RES, CHIP	1M	5%	1/10W	R1307	1-216-041-00	RES, CHIP	470	5% 1/10W
R1222	1-216-073-00	RES, CHIP	10K	5%	1/10W	R1308	1-208-776-11	RES, CHIP	560	0.50% 1/10W
R1223	1-216-097-91	RES, CHIP	100K	5%	1/10W	R1309	1-216-025-91	RES, CHIP	100	5% 1/10W
R1224	1-216-089-91	RES, CHIP	47K	5%	1/10W	R2015	1-216-081-00	RES, CHIP	22K	5% 1/10W
R1225	1-216-097-91	RES, CHIP	100K	5%	1/10W	R2016	1-216-069-00	RES, CHIP	6.8K	5% 1/10W
						R2017	1-216-295-91	SHORT		

UY COMPLETE PARTS LISTING

<u>REF.NO.</u>	<u>PART NO.</u>	<u>DESCRIPTION</u>		<u>REMARK</u>			<u>REF.NO.</u>	<u>PART NO.</u>	<u>DESCRIPTION</u>	<u>REMARK</u>
R2018	1-216-295-91	SHORT								
R2021	1-216-081-00	RES, CHIP	22K	5%	1/10W					
R2027	1-216-049-91	RES, CHIP	1K	5%	1/10W					
R2028	1-216-049-91	RES, CHIP	1K	5%	1/10W					
R2029	1-216-043-91	RES, CHIP	560	5%	1/10W					
R2030	1-216-043-91	RES, CHIP	560	5%	1/10W					
R2031	1-216-081-00	RES, CHIP	22K	5%	1/10W					
R2032	1-216-067-00	RES, CHIP	5.6K	5%	1/10W					
R2033	1-208-790-11	RES, CHIP	2.2K	0.50%	1/10W					
R2034	1-216-057-00	RES, CHIP	2.2K	5%	1/10W					
R2035	1-216-049-91	RES, CHIP	1K	5%	1/10W					
R2036	1-208-775-11	RES, CHIP	510	0.50%	1/10W					
R2037	1-208-784-11	RES, CHIP	1.2K	0.50%	1/10W					
R2038	1-208-762-11	RES, CHIP	150	0.50%	1/10W					
R2039	1-216-047-91	RES, CHIP	820	5%	1/10W					
R2040	1-216-057-00	RES, CHIP	2.2K	5%	1/10W					
R2041	1-216-047-91	RES, CHIP	820	5%	1/10W					
R2042	1-216-075-00	RES, CHIP	12K	5%	1/10W					
R2043	1-216-085-00	RES, CHIP	33K	5%	1/10W					
R2044	1-208-790-11	RES, CHIP	2.2K	0.50%	1/10W					
R2046	1-216-075-00	RES, CHIP	12K	5%	1/10W					
R2047	1-216-085-00	RES, CHIP	33K	5%	1/10W					
R2048	1-216-049-91	RES, CHIP	1K	5%	1/10W					
R2050	1-216-017-91	RES, CHIP	47	5%	1/10W					
R2051	1-216-049-91	RES, CHIP	1K	5%	1/10W					
R2055	1-216-017-91	RES, CHIP	47	5%	1/10W					
R2057	1-216-049-91	RES, CHIP	1K	5%	1/10W					
R2060	1-216-025-91	RES, CHIP	100	5%	1/10W					
R2069	1-208-774-11	RES, CHIP	470	0.50%	1/10W					
R2070	1-216-615-91	METAL	33	0.50%	1/10W					
R2071	1-216-067-00	RES, CHIP	5.6K	5%	1/10W					
R2072	1-216-043-91	RES, CHIP	560	5%	1/10W					
R2073	1-216-049-91	RES, CHIP	1K	5%	1/10W					
R2074	1-216-025-91	RES, CHIP	100	5%	1/10W					
R2081	1-216-075-00	RES, CHIP	12K	5%	1/10W					
R2201	1-216-022-00	RES, CHIP	75	5%	1/10W					
R2202	1-216-022-00	RES, CHIP	75	5%	1/10W					
R2203	1-216-022-00	RES, CHIP	75	5%	1/10W					
R3511	1-216-295-91	SHORT								
R3527	1-216-033-00	RES, CHIP	220	5%	1/10W					
R3582	1-216-033-00	RES, CHIP	220	5%	1/10W					
R3583	1-216-061-00	RES, CHIP	3.3K	5%	1/10W					
R3584	1-216-057-00	RES, CHIP	2.2K	5%	1/10W					
R3585	1-216-061-00	RES, CHIP	3.3K	5%	1/10W					
R3586	1-216-295-91	SHORT								
R3590	1-216-295-91	SHORT								
R3591	1-216-295-91	SHORT								
R3592	1-216-091-00	RES, CHIP	56K	5%	1/10W					
R3593	1-216-043-91	RES, CHIP	560	5%	1/10W					
R3594	1-216-295-91	SHORT								
R3595	1-216-295-91	SHORT								
R3599	1-216-295-91	SHORT								



COMPLETE PARTS LISTING

REF.NO. PART NO. DESCRIPTION REMARK



PIP SCHEMATIC (FOR UY MAIN COMPONENTS SEE PAGE 114)

- * **A-1394-938-A UY BOARD, COMPLETE**
(KV-32FS10/34FV10/36FS10 only)
- * **A-1394-943-A UY BOARD, COMPLETE**
(KV-32FV15/36FV15 only)
- * **A-1394-944-A UY BOARD, COMPLETE**
(KV-34FV15/34FV15C/34FV15K/34FV15T/38FV15K only)

CAPACITOR

C3301	1-104-664-11	ELECT	47µF	20%	25V
C3302	1-163-031-11	CERAMIC	0.01µF		50V
C3319	1-163-031-11	CERAMIC	0.01µF		50V
C3320	1-126-960-11	ELECT	1µF	20%	50V
C3321	1-163-231-11	CERAMIC	15pF	5%	50V
C3322	1-163-231-11	CERAMIC	15pF	5%	50V

(KV-32FV15/36FV1534FV15/34FV15C/34FV15K/34FV15T/38FV15K only)

C3323	1-163-031-11	CERAMIC	0.01µF		50V
-------	--------------	---------	--------	--	-----

(KV-32FV15/36FV1534FV15/34FV15C/34FV15K/34FV15T/38FV15K only)

C3324	1-126-926-11	ELECT	1000µF	20%	10V
C3325	1-126-926-11	ELECT	1000µF	20%	10V
C3328	1-126-925-11	ELECT	470µF	20%	10V
C3329	1-104-664-11	ELECT	47µF	20%	16V
C3330	1-163-031-11	CERAMIC	0.01µF		50V

(KV-32FV15/36FV1534FV15/34FV15C/34FV15K/34FV15T/38FV15K only)

C3331	1-104-664-11	ELECT	47µF	20%	16V
C3332	1-104-664-11	ELECT	47µF	20%	25V
C3334	1-163-031-11	CERAMIC	0.01µF		50V
C3340	1-163-031-11	CERAMIC	0.01µF		50V
C3342	1-163-009-11	CERAMIC	0.001µF	10%	50V

(KV-32FV15/36FV1534FV15/34FV15C/34FV15K/34FV15T/38FV15K only)

C3346	1-163-251-11	CERAMIC	100pF	5%	50V
C3347	1-126-960-11	ELECT	1µF	20%	50V
C3348	1-104-664-11	ELECT	47µF	20%	16V
C3349	1-163-249-11	CERAMIC	82pF	5%	50V
C3350	1-164-004-11	CERAMIC	0.1µF	10%	25V

(KV-32FV15/36FV1534FV15/34FV15C/34FV15K/34FV15T/38FV15K only)

C3352	1-163-031-11	CERAMIC	0.01µF		50V
C3353	1-126-960-11	ELECT	1µF	20%	50V
C3354	1-163-031-11	CERAMIC	0.01µF		50V
C3355	1-126-967-11	ELECT	47µF	20%	50V
C3356	1-163-038-91	CERAMIC	0.1µF		25V

(KV-32FV15/36FV1534FV15/34FV15C/34FV15K/34FV15T/38FV15K only)

C3357	1-163-038-91	CERAMIC	0.1µF		25V
C3358	1-163-038-91	CERAMIC	0.1µF		25V
C3359	1-163-038-91	CERAMIC	0.1µF		25V
C3360	1-163-038-91	CERAMIC	0.1µF		25V
C3361	1-163-038-91	CERAMIC	0.1µF		25V

(KV-32FV15/36FV1534FV15/34FV15C/34FV15K/34FV15T/38FV15K only)

REF.NO. PART NO. DESCRIPTION REMARK

C3362	1-126-967-11	ELECT	47µF	20%	50V
C3363	1-163-031-11	CERAMIC	0.01µF		50V
C3364	1-163-229-11	CERAMIC	12pF	5%	50V
C3365	1-163-133-00	CERAMIC	470pF	5%	50V
C3366	1-126-959-11	ELECT	0.47µF	20%	50V

(KV-32FV15/36FV1534FV15/34FV15C/34FV15K/34FV15T/38FV15K only)

C3367	1-126-963-11	ELECT	4.7µF	20%	50V
C3368	1-164-005-11	CERAMIC	0.47µF		25V
C3369	1-163-251-11	CERAMIC	100pF	5%	50V
C3370	1-126-960-11	ELECT	1µF	20%	50V
C3371	1-163-017-00	CERAMIC	0.0047µF	10%	50V
C3372	1-164-005-11	CERAMIC	0.47µF		25V

(KV-32FV15/36FV15/34FV15/34FV15C/34FV15K/34FV15T/38FV15K only)

C3377	1-164-004-11	CERAMIC	0.1µF	10%	25V
C3378	1-163-006-11	CERAMIC	560pF	10%	50V
C3380	1-164-004-11	CERAMIC	0.1µF	10%	25V
C3381	1-163-019-00	CERAMIC	0.0068µF	10%	50V
C3382	1-164-344-11	CERAMIC	0.068µF	10%	25V
C3383	1-126-956-91	ELECT	0.1µF	20%	50V

(KV-32FV15/36FV15 only)

C3385	1-126-941-11	ELECT	470µF	20%	25V
-------	--------------	-------	-------	-----	-----

(KV-32FV15/36FV15/34FV15/34FV15C/34FV15K/34FV15T/38FV15K only)

FERRITE BEAD

FB3301	1-414-234-22	INDUCTOR			
FB3302	1-414-234-22	INDUCTOR			

(KV-32FV15/36FV15/34FV15/34FV15C/34FV15K/34FV15T/38FV15K only)

IC

IC3302	8-759-358-38	IC NJM78M05DLA(TE1)			
IC3303	8-759-533-89	IC SDA9288XE-GEG-B12			
IC3304	8-752-086-80	IC CXA2019AQ-T4			

(KV-32FV15/36FV15/34FV15/34FV15C/34FV15K/34FV15T/38FV15K only)

IC3307	8-759-575-50	IC Z8613012SSC			
IC3308	8-759-932-69	IC BU4053BCF-T2			

(KV-32FV15/36FV15/34FV15/34FV15C/34FV15K/34FV15T/38FV15K only)

COIL

L3301	1-414-856-11	INDUCTOR	10µH		
L3302	1-410-473-11	INDUCTOR	18µH		
L3303	1-410-473-11	INDUCTOR	18µH		
L3305	1-408-619-31	INDUCTOR	220µH		
L3306	1-414-857-11	INDUCTOR	100µH		
L3307	1-414-856-11	INDUCTOR	10µH		

(KV-32FV15/36FV15/34FV15/34FV15C/34FV15K/34FV15T/38FV15K only)

UY COMPLETE PARTS LISTING

REF.NO.	PART NO.	DESCRIPTION	REMARK
TRANSISTOR			
Q3301	8-729-422-27	TRANSISTOR 2SD601A-Q	
Q3302	8-729-216-22	TRANSISTOR 2SA1162-G	
Q3305	8-729-216-22	TRANSISTOR 2SA1162-G	
Q3306	8-729-216-22	TRANSISTOR 2SA1162-G	(KV-32FV15/36FV15/34FV15/34FV15C/34FV15K/34FV15T/38FV15K only)
Q3307	8-729-216-22	TRANSISTOR 2SA1162-G	
Q3310	8-729-422-27	TRANSISTOR 2SD601A-Q	
Q3312	8-729-216-22	TRANSISTOR 2SA1162-G	
Q3314	8-729-216-22	TRANSISTOR 2SA1162-G	(KV-32FV15/36FV15/34FV15/34FV15C/34FV15K/34FV15T/38FV15K only)
Q3322	8-729-422-27	TRANSISTOR 2SD601A-Q	(KV-32FV15/36FV15 only)
RESISTOR			
R3301	1-216-295-91	SHORT	(KV-32FV15/36FV15/34FV15/34FV15C/34FV15K/34FV15T/38FV15K only)
R3303	1-216-295-91	SHORT	
R3304	1-216-295-91	SHORT	
R3305	1-216-057-00	RES, CHIP 2.2K	5% 1/10W
R3306	1-216-295-91	SHORT	(KV-32FV15/36FV15/34FV15/34FV15C/34FV15K/34FV15T/38FV15K only)
R3308	1-216-295-91	SHORT	(KV-32FV15/36FV15 only)
R3309	1-216-041-00	RES, CHIP 470	5% 1/10W
R3312	1-216-037-00	RES, CHIP 330	5% 1/10W
R3313	1-216-295-91	SHORT	
R3314	1-216-049-91	RES, CHIP 1K	5% 1/10W
R3320	1-216-295-91	SHORT	(KV-32FV15/36FV15/34FV15/34FV15C/34FV15K/34FV15T/38FV15K only)
R3322	1-216-065-91	RES, CHIP 4.7K	5% 1/10W (KV-32FV15/36FV15/34FV15/34FV15C/34FV15K/34FV15T/38FV15K only)
R3322	1-216-295-91	SHORT	(KV-32FS10/34FV10/36FS10 only)
R3323	1-216-065-91	RES, CHIP 4.7K	5% 1/10W (KV-32FV15/36FV15/34FV15/34FV15C/34FV15K/34FV15T/38FV15K only)
R3323	1-216-295-91	SHORT	(KV-32FS10/34FV10/36FS10 only)
R3324	1-216-065-91	RES, CHIP 4.7K	5% 1/10W (KV-32FV15/36FV15/34FV15/34FV15C/34FV15K/34FV15T/38FV15K only)
R3324	1-216-295-91	SHORT	(KV-32FS10/34FV10/36FS10 only)
R3325	1-216-025-91	RES, CHIP 100	5% 1/10W (KV-32FV15/36FV15 only)
R3326	1-216-295-91	SHORT	
R3329	1-216-069-00	RES, CHIP 6.8K	5% 1/10W
R3332	1-216-033-00	RES, CHIP 220	5% 1/10W
R3337	1-216-033-00	RES, CHIP 220	5% 1/10W
R3338	1-216-033-00	RES, CHIP 220	5% 1/10W (KV-32FV15/36FV15/34FV15/34FV15C/34FV15K/34FV15T/38FV15K only)

REF.NO.	PART NO.	DESCRIPTION	REMARK
R3339	1-216-049-91	RES, CHIP 1K	5% 1/10W
R3340	1-216-041-00	RES, CHIP 470	5% 1/10W
R3341	1-216-057-00	RES, CHIP 2.2K	5% 1/10W
R3342	1-216-057-00	RES, CHIP 2.2K	5% 1/10W
R3343	1-216-049-91	RES, CHIP 1K	5% 1/10W (KV-32FV15/36FV15/34FV15/34FV15C/34FV15K/34FV15T/38FV15K only)
R3346	1-216-049-91	RES, CHIP 1K	5% 1/10W
R3350	1-216-295-91	SHORT	
R3351	1-216-295-91	SHORT	
R3352	1-216-049-91	RES, CHIP 1K	5% 1/10W
R3355	1-216-295-91	SHORT	(KV-32FV15/36FV15/34FV15/34FV15C/34FV15K/34FV15T/38FV15K only)
R3357	1-216-295-91	SHORT	
R3358	1-216-047-91	RES, CHIP 820	5% 1/10W
R3359	1-216-047-91	RES, CHIP 820	5% 1/10W
R3360	1-216-053-00	RES, CHIP 1.5K	5% 1/10W
R3361	1-216-045-00	RES, CHIP 680	5% 1/10W (KV-32FV15/36FV15/34FV15/34FV15C/34FV15K/34FV15T/38FV15K only)
R3362	1-208-768-11	RES, CHIP 240	0.50% 1/10W
R3363	1-208-766-11	RES, CHIP 220	0.50% 1/10W
R3364	1-208-769-11	RES, CHIP 300	0.50% 1/10W
R3370	1-216-295-91	SHORT	
R3375	1-216-041-00	RES, CHIP 470	5% 1/10W (KV-32FV15/36FV15/34FV15/34FV15C/34FV15K/34FV15T/38FV15K only)
R3376	1-216-071-00	RES, CHIP 8.2K	5% 1/10W
R3377	1-216-073-00	RES, CHIP 10K	5% 1/10W
R3378	1-216-053-00	RES, CHIP 1.5K	5% 1/10W
R3379	1-216-077-00	RES, CHIP 15K	5% 1/10W
R3380	1-216-295-91	SHORT	
R3381	1-216-295-91	SHORT	(KV-32FV15/36FV15/34FV15/34FV15C/34FV15K/34FV15T/38FV15K only)
R3382	1-216-057-00	RES, CHIP 2.2K	5% 1/10W
R3383	1-216-025-91	RES, CHIP 100	5% 1/10W
R3384	1-216-033-00	RES, CHIP 220	5% 1/10W
R3385	1-216-109-00	RES, CHIP 330K	5% 1/10W
R3387	1-216-295-91	SHORT	
R3388	1-216-295-91	SHORT	(KV-32FV15/36FV15/34FV15/34FV15C/34FV15K/34FV15T/38FV15K only)
R3392	1-216-295-91	SHORT	
R3393	1-216-025-91	RES, CHIP 100	5% 1/10W
R3394	1-216-041-00	RES, CHIP 470	5% 1/10W (KV-32FV15/36FV15 only)
R3395	1-216-061-91	RES, CHIP 3.3K	5% 1/10W (KV-32FV15/36FV15/34FV15/34FV15C/34FV15K/34FV15T/38FV15K only)
R3398	1-216-069-00	RES, CHIP 6.8K	5% 1/10W
R3399	1-216-025-91	RES, CHIP 100	5% 1/10W
R3401	1-216-025-91	RES, CHIP 100	5% 1/10W
R3402	1-216-025-91	RES, CHIP 100	5% 1/10W
R3404	1-216-073-00	RES, CHIP 10K	5% 1/10W (KV-32FV15/36FV15 only)
CRYSTAL			
X3302	1-760-095-21	VIBRATOR, CRYSTAL	
X3303	1-577-611-11	OSCILLATOR CERAMIC	
X3304	1-567-505-11	OSCILLATOR CRYSTAL	(KV-32FV15/36FV15/34FV15/34FV15C/34FV15K/34FV15T/38FV15K only)

COMPLETE PARTS LISTING



REF.NO.	PART NO.	DESCRIPTION	REMARK	REF.NO.	PART NO.	DESCRIPTION	REMARK
WA				CONNECTOR			
* A-1375-187-A WA BOARD, COMPLETE (All Models)				CN941 *	1-564-511-11	PLUG, CONNECTOR 8P	
4-382-854-11 SCREW (M3X10), P, SW (+)				CN942 *	1-564-508-11	PLUG, CONNECTOR 5P	
				CN961 *	1-770-723-11	CONNECTOR, BOARD TO BOARD 8P	
				CN981 *	1-564-506-11	PLUG, CONNECTOR 3P	
CAPACITOR				DIODE			
C941	1-126-942-61	ELECT	1000µF 20% 25V	D941	8-719-991-33	DIODE 1SS133T-77	
C944	1-126-964-11	ELECT	10µF 20% 50V	D943	8-719-991-33	DIODE 1SS133T-77	
C946	1-104-665-11	ELECT	100µF 20% 25V	D944	8-719-991-33	DIODE 1SS133T-77	
C947	1-104-664-11	ELECT	47µF 20% 25V	D945	8-719-109-89	DIODE RD5.6ESB2	
C949	1-161-830-00	CERAMIC	0.0047µF 500V	D946	8-719-110-88	DIODE RD39ESB2	
C950	1-126-941-11	ELECT	470µF 20% 25V	D947	8-719-110-88	DIODE RD39ESB2	
C951	1-107-645-11	ELECT	22µF 20% 160V	D962	8-719-991-33	DIODE 1SS133T-77	
C952	1-104-999-11	MYLAR	0.1µF 10% 200V	D963	8-719-404-50	DIODE MA111-TX	
C953	1-106-383-00	MYLAR	0.047µF 10% 200V	D964	8-719-210-21	DIODE 11EQS04	
C954	1-130-471-00	FILM	0.001µF 5% 50V	D966	8-719-302-43	DIODE EL1Z	
C955	1-107-667-11	ELECT	2.2µF 20% 160V	D1961	8-719-991-33	DIODE 1SS133T-77	
C956	1-130-471-00	FILM	0.001µF 5% 50V	D1962	8-719-991-33	DIODE 1SS133T-77	
C957	1-106-383-00	MYLAR	0.047µF 10% 200V	IC			
C958	1-126-941-11	ELECT	470µF 20% 25V	IC961	8-759-803-42	IC LA6500-FA	
C960	1-163-021-91	CERAMIC CHIP	0.01µF 10% 50V	IC962	8-759-729-03	IC NJM2903D	
C961	1-164-004-11	CERAMIC CHIP	0.1µF 10% 25V	IC963	8-759-729-03	IC NJM2903D	
C962	1-126-964-11	ELECT	10µF 20% 50V	IC964	8-759-700-42	IC NJM2904D	
C963	1-126-964-11	ELECT	10µF 20% 50V	IC965	8-759-701-59	IC NJM78M09FA	
C964	1-110-501-11	CERAMIC CHIP	0.33µF 10% 16V	COIL			
C965	1-104-664-11	ELECT	47µF 20% 25V	L961	1-459-111-00	INDUCTOR 10MMH	
C966	1-126-960-11	ELECT	1µF 20% 50V	L964	1-406-989-21	INDUCTOR 10MMH	
C967	1-126-964-11	ELECT	10µF 20% 50V	TRANSISTOR			
C968	1-163-021-91	CERAMIC CHIP	0.01µF 10% 50V	Q941	8-729-422-27	TRANSISTOR 2SD601A-Q	
C970	1-163-021-91	CERAMIC CHIP	0.01µF 10% 50V	Q942	8-729-216-22	TRANSISTOR 2SA1162-G	
C971	1-104-664-11	ELECT	47µF 20% 25V	Q943	8-729-422-27	TRANSISTOR 2SD601A-Q	
C972	1-163-251-11	CERAMIC CHIP	100pF 5% 50V	Q944	8-729-422-27	TRANSISTOR 2SD601A-Q	
C973	1-163-021-91	CERAMIC CHIP	0.01µF 10% 50V	Q945	8-729-422-27	TRANSISTOR 2SD601A-Q	
C974	1-137-370-11	FILM	0.01µF 5% 50V	Q946	8-729-045-05	TRANSISTOR 2SA2005	
C976	1-130-967-00	FILM	0.0027µF 5% 50V	Q947	8-729-045-04	TRANSISTOR 2SC5511	
C977	1-104-760-11	CERAMIC CHIP	0.047µF 10% 50V	Q948	8-729-422-27	TRANSISTOR 2SD601A-Q	
C1941	1-126-941-11	ELECT	470µF 20% 25V	Q949	8-729-216-22	TRANSISTOR 2SA1162-G	
C1946	1-136-165-00	FILM	0.1µF 5% 50V	Q961	8-729-422-27	TRANSISTOR 2SD601A-Q	
C1947	1-136-165-00	FILM	0.1µF 5% 50V	Q962	8-729-119-76	TRANSISTOR 2SA1175-HFE	
C1948	1-164-161-11	CERAMIC CHIP	0.0022µF 10% 50V	Q963	8-729-119-76	TRANSISTOR 2SA1175-HFE	
C1949	1-126-934-11	ELECT	220µF 20% 16V	Q965	8-729-931-45	TRANSISTOR IRF614	
C1961	1-129-725-00	FILM	0.082µF 5% 400V	Q966	8-729-216-22	TRANSISTOR 2SA1162-G	
C1962	1-163-021-91	CERAMIC CHIP	0.01µF 10% 50V	Q967	8-729-140-97	TRANSISTOR 2SB734-34	
C1965	1-136-601-11	FILM	0.01µF 5% 630V	Q968	8-729-422-27	TRANSISTOR 2SD601A-Q	
C1966	1-137-378-11	FILM	0.22µF 5% 50V	Q969	8-729-422-27	TRANSISTOR 2SD601A-Q	
C1968	1-137-378-11	FILM	0.22µF 5% 50V				
C1972	1-104-664-11	ELECT	47µF 20% 25V				
C1974	1-104-664-11	ELECT	47µF 20% 25V				



COMPLETE PARTS LISTING

The components identified by shading and mark Δ are critical for safety. Replace only with part number specified.

Les composants identifiés par un trame et une marque Δ sont critiques pour la sécurité. Ne les remplacer que par une pièce portant le numéro spécifié.

REF.NO.	PART NO.	DESCRIPTION	REMARK
Q1961	8-729-140-97	TRANSISTOR 2SB734-34	
Q1963	8-729-216-22	TRANSISTOR 2SA1162-G	
Q1964	8-729-216-22	TRANSISTOR 2SA1162-G	
Q1966	8-729-422-27	TRANSISTOR 2SD601A-Q	
Q1967	8-729-216-22	TRANSISTOR 2SA1162-G	
RESISTOR			
R943	1-216-033-00	RES, CHIP 220	5% 1/10W
R944	1-216-049-91	RES, CHIP 1K	5% 1/10W
R945	1-216-049-91	RES, CHIP 1K	5% 1/10W
R946	1-215-886-11	METAL OXIDE 100	5% 2W F
R947	1-216-025-91	RES, CHIP 100	5% 1/10W
R949	1-216-057-00	RES, CHIP 2.2K	5% 1/10W
R950	1-216-049-91	RES, CHIP 1K	5% 1/10W
R951	1-216-049-91	RES, CHIP 1K	5% 1/10W
R952	1-216-041-00	RES, CHIP 470	5% 1/10W
R953	1-216-021-00	RES, CHIP 68	5% 1/10W
R954	1-216-033-00	RES, CHIP 220	5% 1/10W
R955	1-216-047-91	RES, CHIP 820	5% 1/10W
R956	1-216-025-91	RES, CHIP 100	5% 1/10W
R957	1-216-073-00	RES, CHIP 10K	5% 1/10W
R958	1-216-025-91	RES, CHIP 100	5% 1/10W
R959	1-216-021-00	RES, CHIP 68	5% 1/10W
R960	1-216-065-91	RES, CHIP 4.7K	5% 1/10W
R961	1-216-091-00	RES, CHIP 56K	5% 1/10W
R962	1-216-081-00	RES, CHIP 22K	5% 1/10W
R963	1-216-065-91	RES, CHIP 4.7K	5% 1/10W
R964	1-216-073-00	RES, CHIP 10K	5% 1/10W
R965	1-216-073-00	RES, CHIP 10K	5% 1/10W
R966	1-216-073-00	RES, CHIP 10K	5% 1/10W
R967	1-216-073-00	RES, CHIP 10K	5% 1/10W
R968	1-216-061-00	RES, CHIP 3.3K	5% 1/10W
R969	1-216-025-91	RES, CHIP 100	5% 1/10W
R970	1-208-822-11	RES, CHIP 47K	0.50% 1/10W
R971	1-216-049-91	RES, CHIP 1K	5% 1/10W
R972	1-216-065-91	RES, CHIP 4.7K	5% 1/10W
R973	1-216-057-00	RES, CHIP 2.2K	5% 1/10W
R974	1-208-808-11	RES, CHIP 12K	0.50% 1/10W
R975	1-216-073-00	RES, CHIP 10K	5% 1/10W
R976	1-216-057-00	RES, CHIP 2.2K	5% 1/10W
R977	1-249-401-11	CARBON 47	5% 1/4W F
R978	1-216-073-00	RES, CHIP 10K	5% 1/10W
R979	1-216-033-00	RES, CHIP 220	5% 1/10W
R980	1-216-073-00	RES, CHIP 10K	5% 1/10W
R981	1-216-081-00	RES, CHIP 22K	5% 1/10W
R982	1-216-055-00	RES, CHIP 1.8K	5% 1/10W
R983	1-214-657-11	METAL 1	1% 1/4W
R984	1-249-383-11	CARBON 1.5	5% 1/4W F
R985	1-215-421-00	METAL 1K	1% 1/4W
R986	1-216-057-00	RES, CHIP 2.2K	5% 1/10W
R988	1-215-429-00	METAL 2.2K	1% 1/4W
R990	1-216-025-91	RES, CHIP 100	5% 1/10W
R991	1-208-800-11	RES, CHIP 5.6K	0.50% 1/10W
R992	1-208-794-11	RES, CHIP 3.3K	0.50% 1/10W

REF.NO.	PART NO.	DESCRIPTION	REMARK
R993	1-216-049-91	RES, CHIP 1K	5% 1/10W
R994	1-216-025-91	RES, CHIP 100	5% 1/10W
R995	1-216-051-00	RES, CHIP 1.2K	5% 1/10W F
R1941	1-260-312-11	CARBON 47	5% 1/2W F
R1942	1-249-387-11	CARBON 3.3	5% 1/4W F
R1943	1-249-414-11	CARBON 560	5% 1/4W F
R1944	1-249-432-11	CARBON 18K	5% 1/4W
R1945	1-215-914-11	METAL OXIDE 330	5% 3W F
R1946	1-249-417-11	CARBON 1K	5% 1/4W F
R1947	1-249-432-11	CARBON 18K	5% 1/4W
R1948	1-249-414-11	CARBON 560	5% 1/4W
R1949	1-249-387-11	CARBON 3.3	5% 1/4W F
R1950	1-249-401-11	CARBON 47	5% 1/4W F
R1951	1-216-097-91	RES, CHIP 100K	5% 1/10W
R1952	1-216-097-91	RES, CHIP 100K	5% 1/10W
R1953	1-216-085-00	RES, CHIP 33K	5% 1/10W
R1954	1-216-089-91	RES, CHIP 47K	5% 1/10W
R1955	1-208-808-11	RES, CHIP 12K	0.50% 1/10W
R1956	1-216-057-00	RES, CHIP 2.2K	5% 1/10W
R1957	1-216-295-91	SHORT	
R1958	1-216-061-00	RES, CHIP 3.3K	5% 1/10W
R1959	1-216-073-00	RES, CHIP 10K	5% 1/10W
R1960	1-216-037-00	RES, CHIP 330	5% 1/10W
R1961	1-208-824-11	RES, CHIP 56K	0.50% 1/10W
R1962	1-208-806-11	RES, CHIP 10K	0.50% 1/10W
R1963	Δ 1-216-033-00	RES, CHIP 220	5% 1/10W
R1964	1-216-057-00	RES, CHIP 2.2K	5% 1/10W
R1967	1-215-489-00	METAL 680K	1% 1/4W
R1969	1-216-073-00	RES, CHIP 10K	5% 1/10W
R1970	1-216-065-91	RES, CHIP 4.7K	5% 1/10W
R1971	1-216-121-91	RES, CHIP 1M	5% 1/10W
R1972	1-216-073-00	RES, CHIP 10K	5% 1/10W
R1973	1-216-035-00	RES, CHIP 270	5% 1/10W
R1975	1-216-067-00	RES, CHIP 5.6K	5% 1/10W
R1976	1-216-295-91	SHORT	
R1978	1-216-025-91	RES, CHIP 100	5% 1/10W
R1980	1-216-041-00	RES, CHIP 470	5% 1/10W
R1981	1-216-081-00	RES, CHIP 22K	5% 1/10W
R1982	1-216-081-00	RES, CHIP 22K	5% 1/10W
R1983	1-216-073-00	RES, CHIP 10K	5% 1/10W
R1984	1-216-089-91	RES, CHIP 47K	5% 1/10W
R1987	1-216-097-91	RES, CHIP 100K	5% 1/10W
R1989	1-208-818-11	RES, CHIP 33K	0.50% 1/10W
R1990	1-216-089-91	RES, CHIP 47K	5% 1/10W
R1991	1-216-081-00	RES, CHIP 22K	5% 1/10W
R1992	1-216-057-00	RES, CHIP 2.2K	5% 1/10W
R2962	1-215-885-00	METAL OXIDE 68	5% 2W F
R2963	1-215-885-00	METAL OXIDE 68	5% 2W F
R2965	1-216-065-91	RES, CHIP 4.7K	5% 1/10W
R2968	1-216-065-91	RES, CHIP 4.7K	5% 1/10W
R2969	1-216-065-91	RES, CHIP 4.7K	5% 1/10W
R2971	1-216-089-91	RES, CHIP 47K	5% 1/10W
R2972	1-216-113-00	RES, CHIP 470K	5% 1/10W
R2973	1-216-025-91	RES, CHIP 100	5% 1/10W



COMPLETE PARTS LISTING

REF.NO.	PART NO.	DESCRIPTION	REMARK
R2975	1-216-061-00	RES, CHIP	3.3K 5% 1/10W
R2976	1-216-025-91	RES, CHIP	100 5% 1/10W
R2979	1-216-097-91	RES, CHIP	100K 5% 1/10W
R2980	1-216-097-91	RES, CHIP	100K 5% 1/10W

VARIABLE RESISTOR

RV941	1-238-019-11	RES, ADJ, CARBON	47K
-------	--------------	------------------	-----

ACCESSORIES AND PACKING MATERIAL

3-866-305-21	MANUAL, INSTRUCTION (English)	(KV-32FS10/32FV15/32XBR250/36FS10/36FV15 only)
3-866-305-31	MANUAL, INSTRUCTION (French)	(KV-32FS10/32FV15/32XBR250/36FS10/36FV15/36XBR250 only)
3-866-305-41	MANUAL, INSTRUCTION (Spanish)	(KV-34FV10/34FV15/34FV15C/34FX250C/38FX250/38FX250C only)
3-866-853-21	MANUAL, INSTRUCTION	(KV-36XBR250 only)
3-866-931-61	MANUAL, INSTRUCTION	(KV-34FV15K/38FV15K only)
3-866-936-71	MANUAL, INSTRUCTION	(KV-34FV15T/38FX250T only)
4-041-259-01	PROTECTION BAG	(KV-32FS10/34FV15K/34FV15T only)
4-053-658-01	PROTECTION BAG	(KV-32FV15/32XBR250/34FV10/34FV15/34FV15C/34FX250C only)
4-066-646-01	PROTECTION BAG	(KV-36FS10/36FV15/36XBR250/38FV15K/38FX250/38FX250C/38FX250T only)
4-068-789-01	CUSHION ASSY, LOWER	(KV-32FV15/32XBR250/34FV15K/34FV15T only)
4-068-789-11	CUSHION ASSY, LOWER	(KV-32FS10/34FV10/34FV15/34FV15C only)
4-068-884-01	CUSHION ASSY, LOWER (KV-36FS10 only)	
4-069-389-01	CUSHION ASSY, LOWER	(KV-34FX250C/36FV15/36XBR250/38FV15K/38FX250/38FX250C/38FX250T only)
4-068-786-01	CUSHION ASSY, UPPER	(KV-32FV15/32XBR250/34FV15K/34FV15T/34FX250C only)
4-068-786-11	CUSHION ASSY, UPPER	(KV-32FS10/34FV10/34FV15/34FV15C only)
4-068-883-01	CUSHION ASSY, UPPER (KV-36FS10 only)	
4-069-390-01	CUSHION ASSY, UPPER	(KV-36FV15/36XBR250/38FV15K/38FX250/38FX250C/38FX250T only)
4-069-471-01	CARTON	(KV-32FV15/34FV15K/34FV15T only)
4-069-471-11	CARTON	(KV-32FS10/34FV10/34FV15/34FV15C only)
4-069-515-01	CARTON	(KV-36FS10/36FV15/38FV15K/38FX250/38FX250C/38FX250T only)
4-070-553-01	CARTON	(KV-32XBR250/34FX250C only)
4-071-107-01	CARTON (KV-36XBR250 only)	

REF.NO.	PART NO.	DESCRIPTION	REMARK
---------	----------	-------------	--------

REMOTE COMMANDER

1-418-387-11	REMOTE COMMANDER (RM-Y168)	(KV-32FS10/34FV10/36FS10 only)
1-418-465-11	REMOTE COMMANDER (RM-Y170)	(KV-32XBR250/34FX250C/36XBR250/38FX250/38FX250C/38FX250T only)
1-418-496-11	REMOTE COMMANDER (RM-Y171)	(KV-32FV15/34FV15/34FV15C/34FV15K/34FV15T/36FV15 only)
1-475-069-21	REMOTE COMMANDER (RM-Y149A)	(KV-38FV15K only)
4-978-977-01	BATTERY COVER (for remote)	(RM-Y149A/RM-Y168/RM-Y170/RM-Y171)

9-965-868-01

Sony Corporation
Sony Technology Center
Product Quality Division
Service Promotion Department

English
99ET74407-01
Printed in USA
1999.5

SERVICE MANUAL

AA2W Chassis

<i>MODEL</i>	<i>DEST</i>	<i>COMMANDER</i>	<i>CHASSIS NO.</i>
KV-32FS10	U.S.	RM-Y168	SCC-S32B-A
KV-32FS10	CND	RM-Y168	SCC-S33B-A
KV-36FS10	U.S.	RM-Y168	SCC-S32C-A
KV-36FS10	CND	RM-Y168	SCC-S33C-A
KV-32FV15	U.S.	RM-Y171	SCC-S32D-A
KV-32FV15	CND	RM-Y171	SCC-S33D-A
KV-34FV10	E	RM-Y168	SCC-S34E-A
KV-34FV15	E	RM-Y171	SCC-S34F-A
KV-34FV15C	E	RM-Y171	SCC-S34G-A
KV-34FV15K	KOREA	RM-Y149A	SCC-S31B-A
KV-34FV15T	TAIWAN	RM-Y171	SCC-S36A-A
KV-36FV15	U.S.	RM-Y171	SCC-S32G-A
KV-36FV15	CND	RM-Y171	SCC-S33G-A
KV-38FV15K	KOREA	RM-Y149A	SCC-S31C-A
KV-34FX250C	E	RM-Y170	SCC-S34H-A
KV-38FX250	E	RM-Y170	SCC-S34M-A
KV-38FX250C	E	RM-Y170	SCC-S34J-A
KV-38FX250T	TAIWAN	RM-Y170	SCC-S36B-A
KV-32XBR250	U.S.	RM-Y170	SCC-S32E-A
KV-32XBR250	CND	RM-Y170	SCC-S33E-A
KV-36XBR250	U.S.	RM-Y170	SCC-S32F-A
KV-36XBR250	CND	RM-Y170	SCC-S33F-A

CORRECTION-1

SUBJECT: A Board Schematic - Critical Component Identified

Correct the service manual as shown.
File this Correction with the service manual.



TRINITRON® COLOR TV
SONY®

Section 6: Schematic Diagram (Page 46) A Board
Critical Component Symbol Added

Incorrect

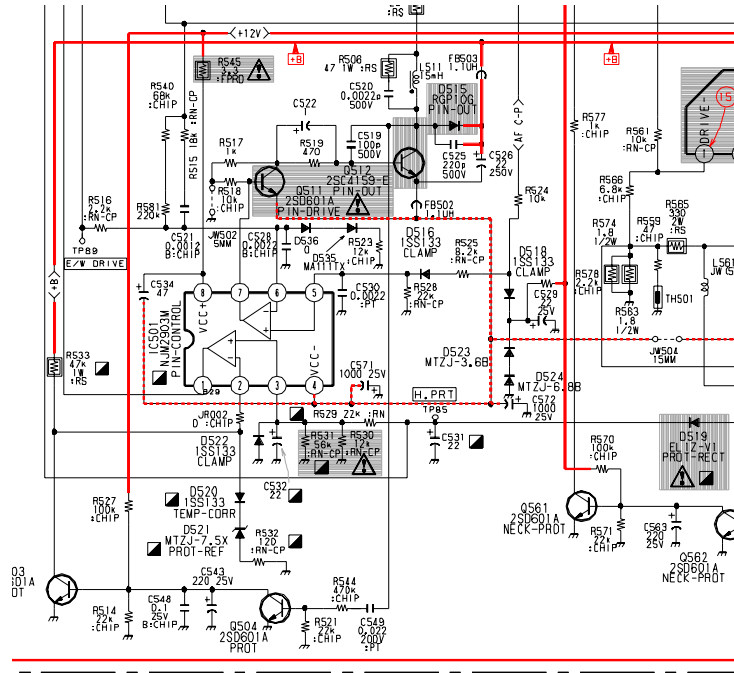

Correct

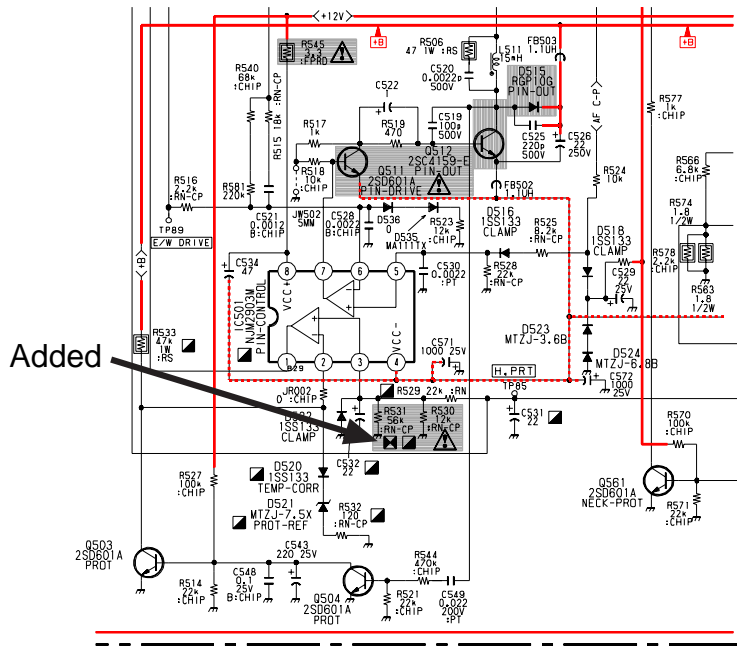

Sony Corporation

Sony Technology Center

Product Quality Division

Service Promotion Department

English

99ET74418-01

Printed in USA

1999.5

9-965-868-91

SERVICE MANUAL

AA-2W CHASSIS

<u>MODEL</u>	<u>DEST.</u>	<u>COMMANDER</u>	<u>CHASSIS NO.</u>
KV-32FS10	U.S.	RM-Y168	SCC-S32B-A
KV-32FS10	CND	RM-Y168	SCC-S33B-A
KV-36FS10	U.S.	RM-Y168	SCC-S32C-A
KV-36FS10	CND	RM-Y168	SCC-S33C-A
KV-32FV15	U.S.	RM-Y171	SCC-S32D-A
KV-32FV15	CND	RM-Y171	SCC-S33D-A
KV-34FV10	E	RM-Y168	SCC-S34E-A
KV-34FV15	E	RM-Y171	SCC-S34F-A
KV-34FV15C	E	RM-Y171	SCC-S34G-A
KV-34FV15K	KOREA	RM-Y149A	SCC-S31B-A
KV-34FV15T	TAIWAN	RM-Y171	SCC-S36A-A
KV-36FV15	U.S.	RM-Y171	SCC-S32G-A
KV-36FV15	CND	RM-Y171	SCC-S33G-A
KV-38FV15K	KOREA	RM-Y149A	SCC-S31C-A
KV-34FX250C	E	RM-Y170	SCC-S34H-A
KV-38FX250	E	RM-Y170	SCC-S34M-A
KV-38FX250C	E	RM-Y170	SCC-S34J-A
KV-38FX250T	TAIWAN	RM-Y170	SCC-S36B-A
KV-32XBR250	U.S.	RM-Y170	SCC-S32E-A
KV-32XBR250	CND	RM-Y170	SCC-S33E-A
KV-36XBR250	U.S.	RM-Y170	SCC-S32F-A
KV-36XBR250	CND	RM-Y170	SCC-S33F-A

CORRECTION-2

Subject: IC002 Part Number Correction

**Correct the service manual as shown.
File this correction with the service manual.**

TRINITRON® COLOR TV
SONY®

SECTION 8 ELECTRICAL PARTS LIST (PAGE 87)

INCORRECT				CORRECT			
<u>REF.NO.</u>	<u>PART NO.</u>	<u>DESCRIPTION</u>	<u>REMARK</u>	<u>REF.NO.</u>	<u>PART NO.</u>	<u>DESCRIPTION</u>	<u>REMARK</u>
IC001	8-752-903-74	IC CXP85856A-024Q		IC001	✎ 8-752-906-87	CXP85856A-029S	

<u>MODEL</u>	<u>DEST</u>	<u>COMMANDER</u>	<u>CHASSIS NO.</u>
KV-32FS10	U.S.	RM-Y168	SCC-S32B-A
KV-32FS10	CND	RM-Y168	SCC-S33B-A
KV-36FS10	U.S.	RM-Y168	SCC-S32C-A
KV-36FS10	CND	RM-Y168	SCC-S33C-A
KV-32FV15	U.S.	RM-Y171	SCC-S32D-A
KV-32FV15	CND	RM-Y171	SCC-S33D-A
KV-34FV10	E	RM-Y168	SCC-S34E-A
KV-34FV15	E	RM-Y171	SCC-S34F-A
KV-34FV15C	E	RM-Y171	SCC-S34G-A
KV-34FV15K	KOREA	RM-Y149A	SCC-S31B-A
KV-34FV15T	TAIWAN	RM-Y171	SCC-S36A-A
KV-36FV15	U.S.	RM-Y171	SCC-S32G-A
KV-36FV15	CND	RM-Y171	SCC-S33G-A
KV-38FV15K	KOREA	RM-Y149A	SCC-S31C-A
KV-34FX250C	E	RM-Y170	SCC-S34H-A
KV-38FX250	E	RM-Y170	SCC-S34M-A
KV-38FX250C	E	RM-Y170	SCC-S34J-A
KV-38FX250T	TAIWAN	RM-Y170	SCC-S36B-A
KV-32XBR250	U.S.	RM-Y170	SCC-S32E-A
KV-32XBR250	CND	RM-Y170	SCC-S33E-A
KV-36XBR250	U.S.	RM-Y170	SCC-S32F-A
KV-36XBR250	CND	RM-Y170	SCC-S33F-A

CORRECTION-3

SUBJECT: G Board Schematic Correction

Correct the service manual as shown.
File this Correction with the service manual.

TRINITRON® COLOR TV
SONY®

Section 6-7: G BOARD SCHEMATIC DIAGRAM PAGE 55
(KV-32FS10/32FV15/32XBR250/34FV15T/36FS10/36FV15/36XBR250/38FX250T ONLY)

Incorrect

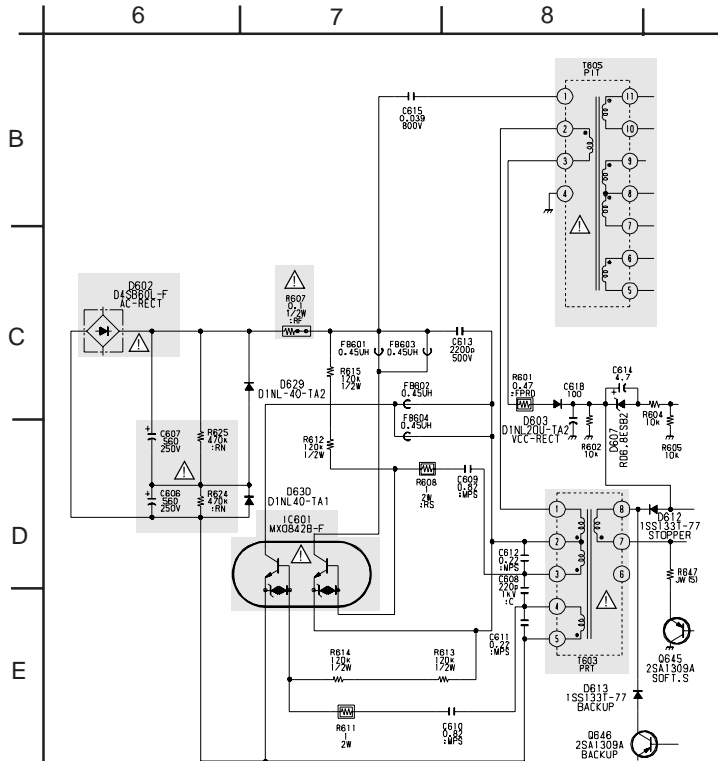

Correct

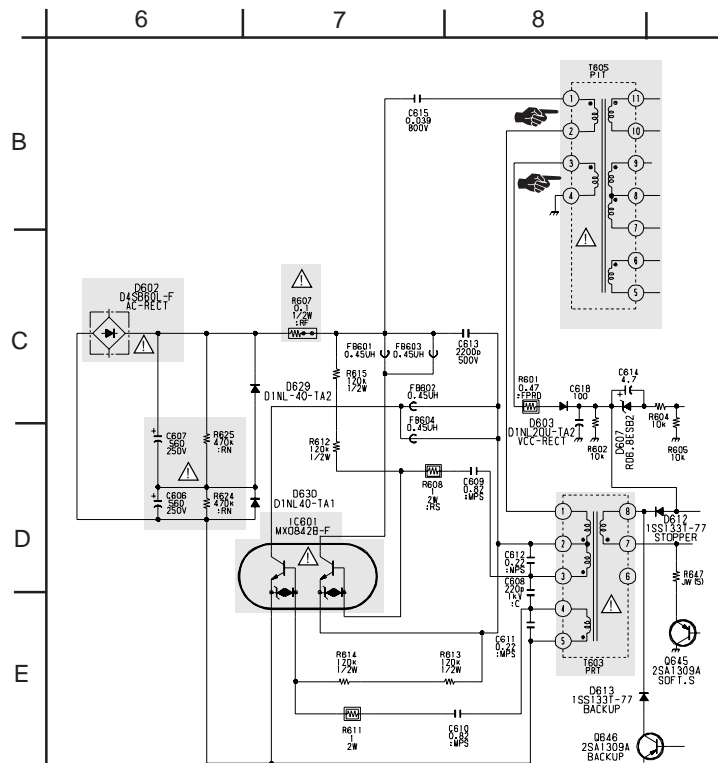

Hand icon: Corrected item

SERVICE MANUAL

AA2W CHASSIS

<i>MODEL</i>	<i>DEST</i>	<i>COMMANDER</i>	<i>CHASSIS NO.</i>
KV-32FS10	U.S.	RM-Y168	SCC-S32B-A
KV-32FS10	CND	RM-Y168	SCC-S33B-A
KV-36FS10	U.S.	RM-Y168	SCC-S32C-A
KV-36FS10	CND	RM-Y168	SCC-S33C-A
KV-32FV15	U.S.	RM-Y171	SCC-S32D-A
KV-32FV15	CND	RM-Y171	SCC-S33D-A
KV-34FV10	E	RM-Y168	SCC-S34E-A
KV-34FV15	E	RM-Y171	SCC-S34F-A
KV-34FV15C	E	RM-Y171	SCC-S34G-A
KV-34FV15K	KOREA	RM-Y149A	SCC-S31B-A
KV-34FV15T	TAIWAN	RM-Y171	SCC-S36A-A
KV-36FV15	U.S.	RM-Y171	SCC-S32G-A
KV-36FV15	CND	RM-Y171	SCC-S33G-A
KV-38FV15K	KOREA	RM-Y149A	SCC-S31C-A
KV-34FX250C	E	RM-Y170	SCC-S34H-A
KV-38FX250	E	RM-Y170	SCC-S34M-A
KV-38FX250C	E	RM-Y170	SCC-S34J-A
KV-38FX250T	TAIWAN	RM-Y170	SCC-S36B-A
KV-32XBR250	U.S.	RM-Y170	SCC-S32E-A
KV-32XBR250	CND	RM-Y170	SCC-S33E-A
KV-36XBR250	U.S.	RM-Y170	SCC-S32F-A
KV-36XBR250	CND	RM-Y170	SCC-S33F-A

CORRECTION- 4

SUBJECT: Corrections to Set-up Adjustments

Correct the service manual as shown.
File this Correction with the service manual.

TRINITRON® COLOR TV

SONY®

SECTION 3 SET-UP ADJUSTMENTS

✎: Corrected item

3-2: CONVERGENCE

(4) TLH Plate Adjustment (page 19)

- Input a crosshatch pattern.
- Adjust PICTURE QUALITY to standard, PICTURE and BRIGHTNESS to 50% and OTHER to standard.
- Adjust the Horizontal Convergence of red and blue dots by tilting the TLH plate on the deflection yoke.

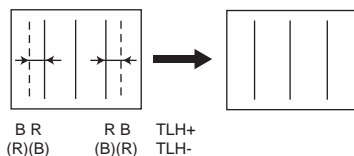
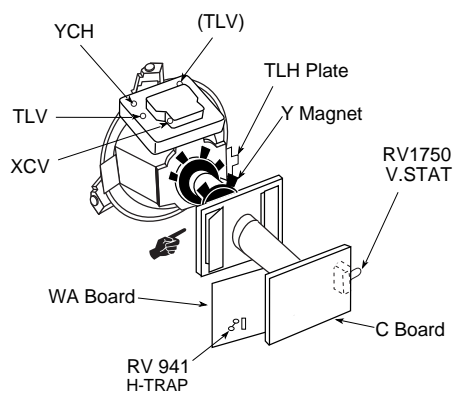

1. Adjust XCV core to balance X axis.
2. Adjust YCH VR to balance Y axis.
3. Adjust vertical red and blue convergence with V.TILT (TLV VR.)

Perform adjustments while tracking items 1 and 2.

- ✎ 4. Adjust Y MAGNET to correct V.BOW Geometry Distortion.
- ✎ 5. Adjust H-TRAP (VR-941) to correct H.TRAPEZOID Geometry Distortion.

After adjusting items 4 and 5, confirm overall geometry again.

3-4: SCREEN (G2) (page 20)

1. Input dot pattern from the pattern generator.
2. Set the user controls to normal.
- ✎ 3. Adjust RCUT, GCUT, BCUT, and SBRT in service mode with an oscilloscope so that voltages on the red, green, and blue cathodes are 170 ± 2 V DC or with a voltmeter so that cathodes are 176 ± 2 V DC.
4. Observe the screen and adjust SCREEN (G2) VR to obtain the fairly visible background of dot signal.
5. Push the TEST +JUMP (+Channel) to cut off the signal, then the screen is bright or dark. Brightness of raster must be increased when adjusting.
6. Adjust screen VR until the screen is just cut off, or scarcely lights up. A signal cannot be seen when the brightness of the raster is high.
7. Push the JUMP again to release the cut off.

SERVICE MANUAL

AA-2W CHASSIS

<i>MODEL</i>	<i>DEST</i>	<i>COMMANDER</i>	<i>CHASSIS NO.</i>
KV-32FS10	U.S.	RM-Y168	SCC-S32B-A
KV-32FS10	CND	RM-Y168	SCC-S33B-A
KV-36FS10	U.S.	RM-Y168	SCC-S32C-A
KV-36FS10	CND	RM-Y168	SCC-S33C-A
KV-32FV15	U.S.	RM-Y171	SCC-S32D-A
KV-32FV15	CND	RM-Y171	SCC-S33D-A
KV-34FV10	E	RM-Y168	SCC-S34E-A
KV-34FV15	E	RM-Y171	SCC-S34F-A
KV-34FV15C	E	RM-Y171	SCC-S34G-A
KV-34FV15K	KOREA	RM-Y149A	SCC-S31B-A
KV-34FV15T	TAIWAN	RM-Y171	SCC-S36A-A
KV-36FV15	U.S.	RM-Y171	SCC-S32G-A
KV-36FV15	CND	RM-Y171	SCC-S33G-A
KV-38FV15K	KOREA	RM-Y149A	SCC-S31C-A
KV-34FX250C	E	RM-Y170	SCC-S34H-A
KV-38FX250	E	RM-Y170	SCC-S34M-A
KV-38FX250C	E	RM-Y170	SCC-S34J-A
KV-38FX250T	TAIWAN	RM-Y170	SCC-S36B-A
KV-32XBR250	U.S.	RM-Y170	SCC-S32E-A
KV-32XBR250	CND	RM-Y170	SCC-S33E-A
KV-36XBR250	U.S.	RM-Y170	SCC-S32F-A
KV-36XBR250	CND	RM-Y170	SCC-S33F-A

SUPPLEMENT - 1

**SUBJECT: HZ Board, Picture Tube View and
Electrical Parts List Update
(Affects KV-34FV15K, 38FV15K only)**

**Correct the service manual as shown.
File this Correction with the service manual.**

✎ : Modified Items

TRINITRON® COLOR TV
SONY®

✎ : Modified Items

**Section 6-7. PRINTED WIRING BOARDS AND SCHEMATIC DIAGRAMS
(KV-34FV15K and KV-38FV15K only)**

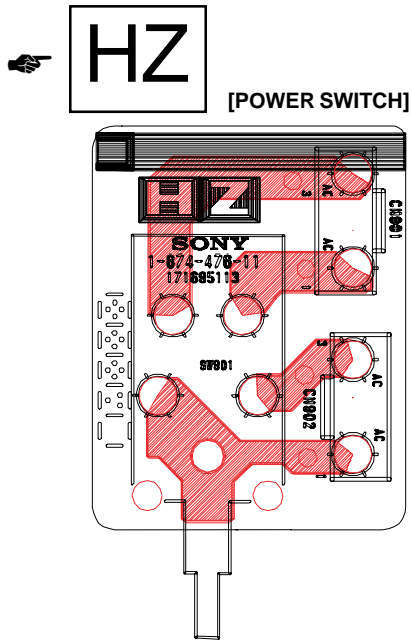

✎ HZ Board Schematic Diagram

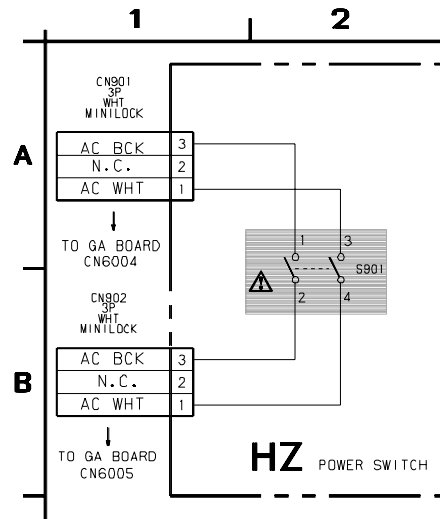

Section 7-3. PICTURE TUBE (Page 81)

Incorrect

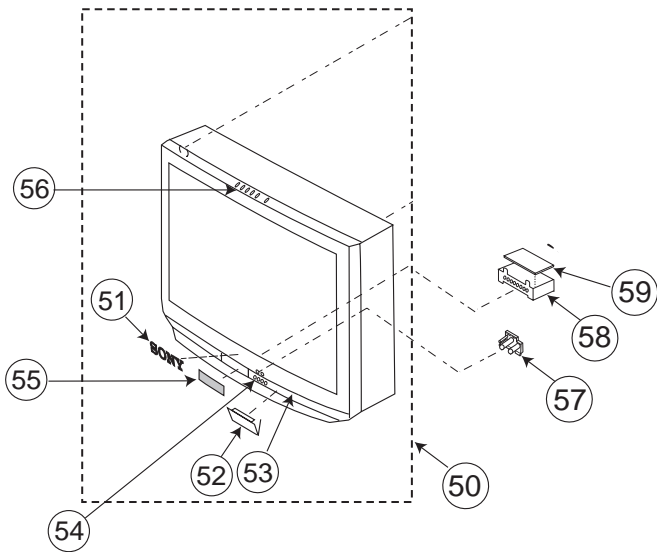

Correct

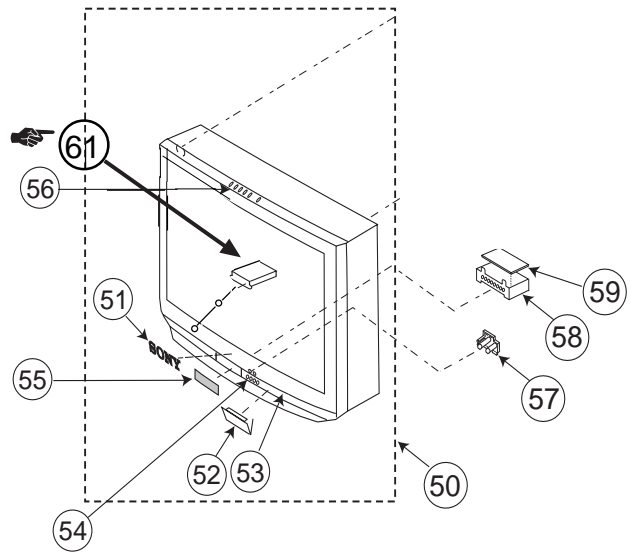

Ref. No	Part No.	Description	Remarks
50	X-4036-679-2	BEZNET ASSY (KV-34FV15K only)	51-53
50	X-4036-684-1	BEZNET ASSY (KV-38FV15K only)	51-53
Needs to be added - - - - - >			

Ref. No.	Part No.	Description	Remarks
50	X-4036-811-2	BEZNET ASSY (KV-34FV15K only)	51-53
50	X-4037-186-2	BEZNET ASSY (KV-38FV15K only)	51-53
61	4-068-995-01	BUTTON, MAIN POWER	

☞ : Modified Items

Section 8. ELECTRICAL PARTS LIST

HZ _____

☞ * A-1372-667-A HZ BOARD, COMPLETE
(KV-34FV15K, 38FV15K only)

CONNECTOR

CN901* 1-573-963-11 PIN, CONNECTOR (PC BOARD) 3P
CN902* 1-573-963-11 PIN, CONNECTOR (PC BOARD) 3P

SWITCH

SW901△ 1-571-433-21 SWITCH, PUSH (AC POWER)

9-965-868-81

Sony Corporation
Sony Technology Center
Product Quality Division
Service Promotion Department

English
99LJ74340-01
Printed in USA
1999.12